



LEDTECH ELECTRONICS CORP.

NANYA ROAD, MUGANG ZHAOQING
CITY GUANGDONG CHINA.

TEL: 86-758-2875541, 2870651, 2877464, 2876185, 2877017

FAX: 86-758-2878014

[Http://www.ledtech.com.tw](http://www.ledtech.com.tw)

SPECIFICATION

PART NO. : LP5KLR-3D-UBK3-27Z

3.2 x 2.8mm SMD TYPE



Approved by

Checked by

Prepared by

Tung

Lian

Karen

Package Dimensions

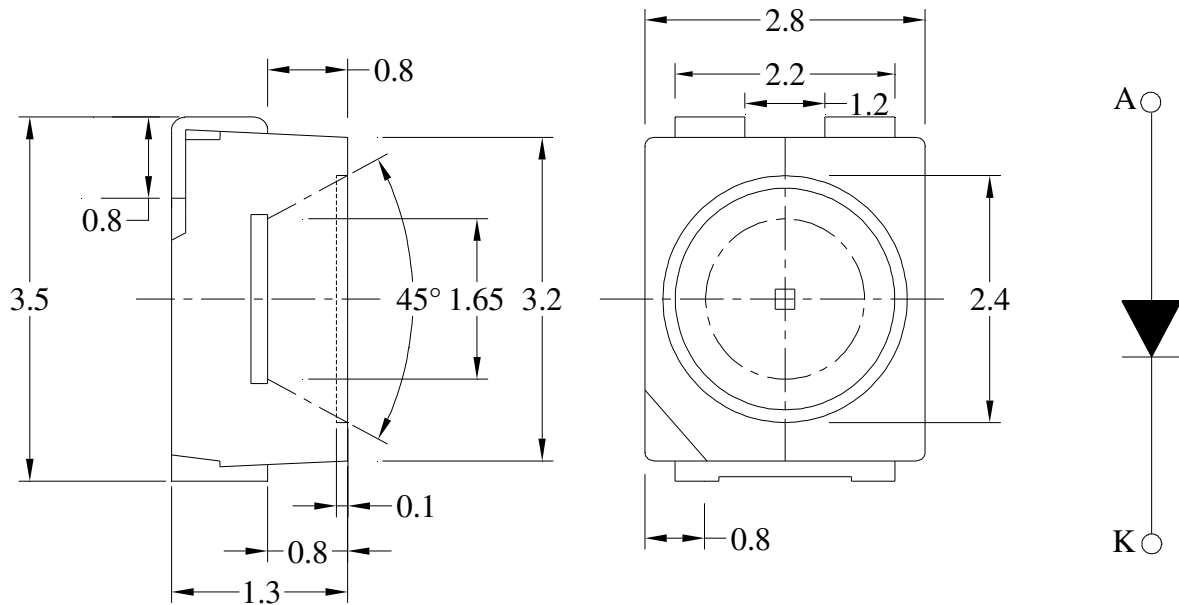

Notes:

1. All dimensions are in mm.
2. Tolerance is ± 0.25 mm unless otherwise noted.

Description

Part No.	LED Chip		Lens Color
	Material	Emitting Color	
LP5KLR-3D-UBK3-27Z	InGaN/Al ₂ O ₃	Warm White	Yellow Diffused

Absolute Maximum Ratings at Ta=25 °C

Parameter	Symbol	Rating	Unit
Power Dissipation	PD	600	mW
LED Junction Temperature		120	°C
Reverse Voltage	VR	5	V
D.C. Forward Current	If	150	mA
Peak Current(1/10Duty Cycle,0.1ms Pulse Width.)	If(Peak)	300	mA
Operating Temperature Range	Topr.	-40 to +75	°C
Storage Temperature Range	Tstg.	-40 to +105	°C
Soldering Temperature	Tsld.	Reflow Soldering: 260°C for 10 sec. Hand Soldering: 350°C for 3 sec.	
Electric Static Discharge Threshold (HBM)	ESD	6000	V

Electrical and Optical Characteristics:

Parameter	Symbol	Condition	Min.	Typ.	Max.	Unit	
Luminous Flux	Φ_v	If=150mA	13.9	20		lm	
Forward Voltage	Vf	If=150mA		3.2	4.0	V	
Correlated Colour Temperature	25	CCT	If=150mA	2500		2600	K
	26			2600	-	2700	
	27			2700	-	2900	
Color Rendering Index(Ra)	CRI	If=150mA		62		Ra	
Reverse Current	Ir	Vr=5V	-	-	50	μ A	
Viewing Angle	2θ 1/2	If=150mA	-	120	-	deg	

Notes: 1.The datas tested by IS tester.

2. Customer's special requirements are also welcome.

Typical Electrical/Optical Characteristic Curves

(25°C Ambient Temperature Unless Otherwise Noted)

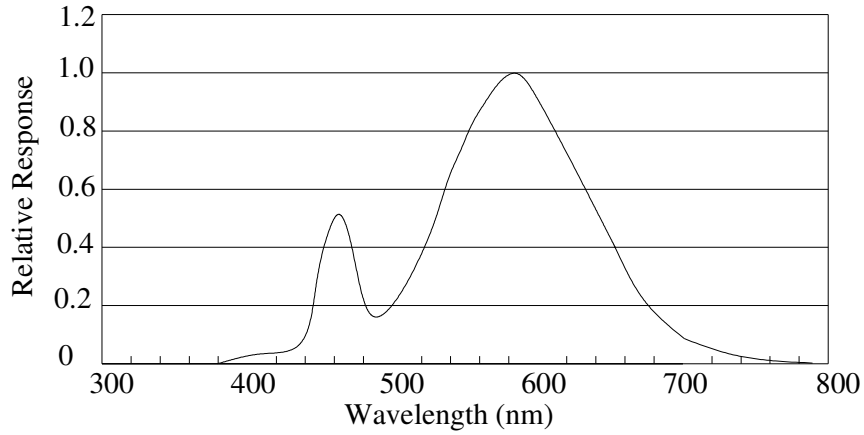
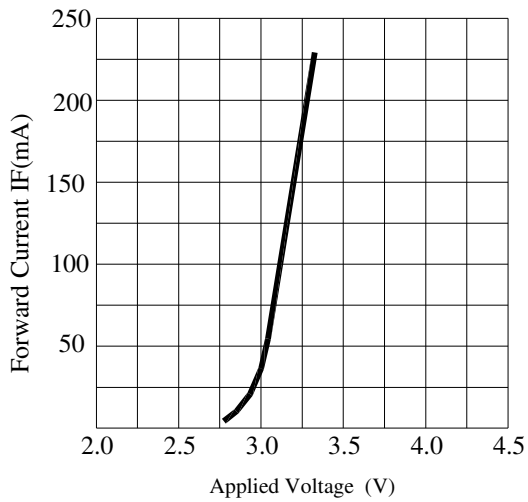
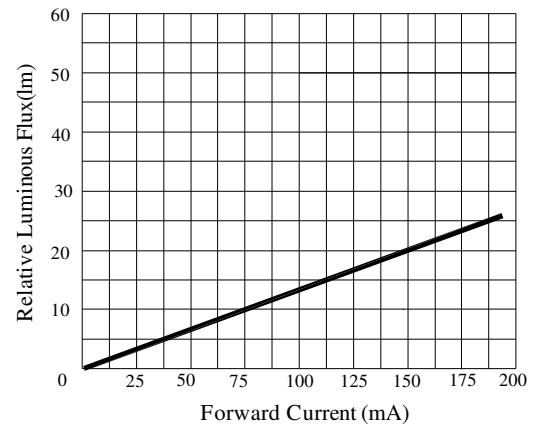

Fig.1 WHITE LED Spectrum VS. WAVELENGTH



Forward Current VS. Applied Voltage



Forward Current VS. Luminous Intensity

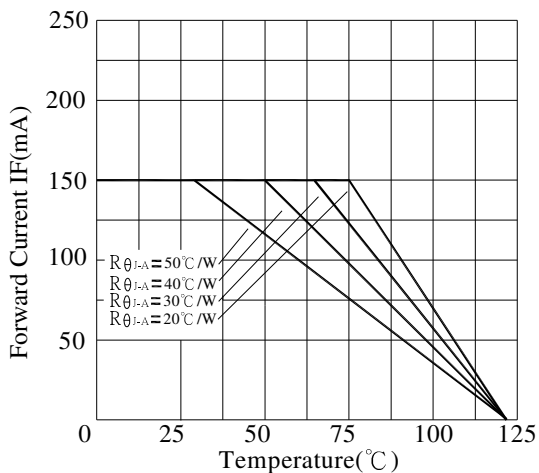

Ambient Temperature VS. Forward Current

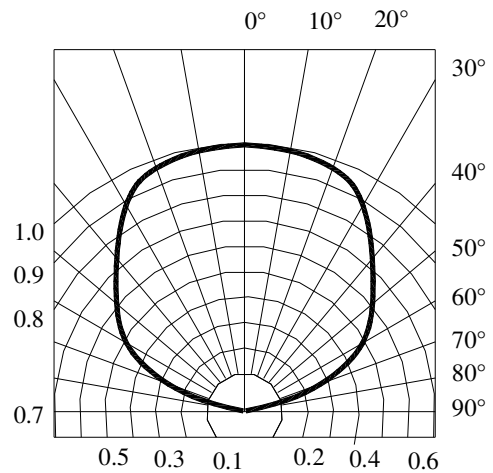

Radiation Diagram

PRECAUTION IN USE

Storage

Recommended storage environment

Temperature: 5°C ~ 30°C (41°F ~ 86°F)

Humidity: 60% RH Max.

Use within 7 days after opening of sealed vapor/ESD barrier bags.

If unused LEDs remain, they should be stored in moisture proof packages, such as sealed container with packages of moisture absorbent material (silica gel). It is also recommended to return the LEDs to the original moisture proof bag and to reseal the moisture proof bag again.

Fold the opened bag firmly and keep in dry environment.

Soldering

	Reflow Soldering		Hand Soldering	
	Lead Solder	Lead – free Solder		
Pre-heat	120~150°C	180~200°C	Temperature	350°C Max.
Pre-heat time	120sec. Max.	120sec. Max.	Soldering time	3sec. Max. (one time only)
Peak temperature	240°C Max.	260°C Max.		
Soldering time	10sec. Max.	10sec. Max.		
Condition	refer to Temperature- profile 1	refer to Temperature- profile 2		

*After reflow soldering rapid cooling should be avoided.

[Temperature-profile (Surface of circuit board)]

Use the conditions shown to the under figure.

< 1 : Lead Solder >

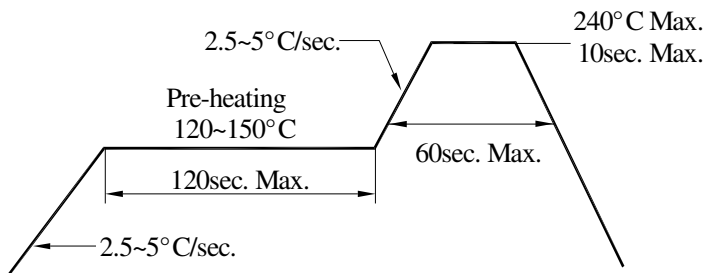

< 2 : Lead-free Solder >

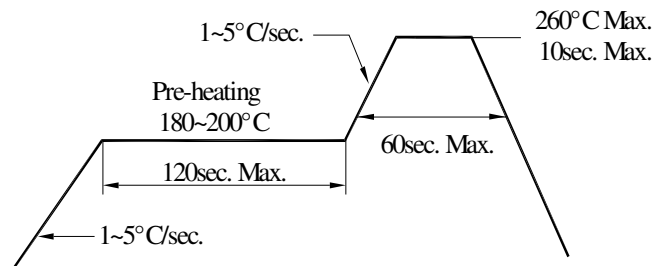

[Recommended soldering pad design]

Use the following conditions shown in the figure.

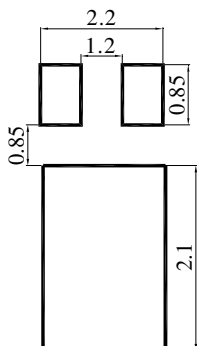

Handling of Silicone Resin LEDs

Handling Indications

During processing, mechanical stress on the surface should be minimized as much as possible. Sharp objects of all types should not be used to pierce the sealing compound

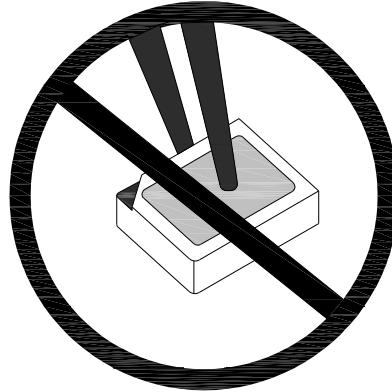

Figure 1

In general, LEDs should only be handled from the side. By the way, this also applies to LEDs without a silicone sealant, since the surface can also become scratched.

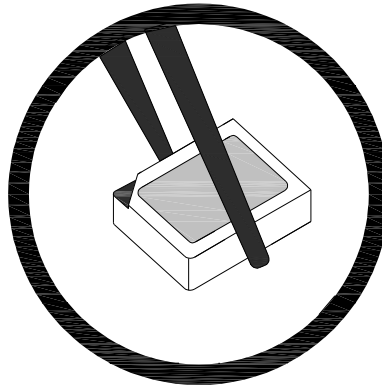
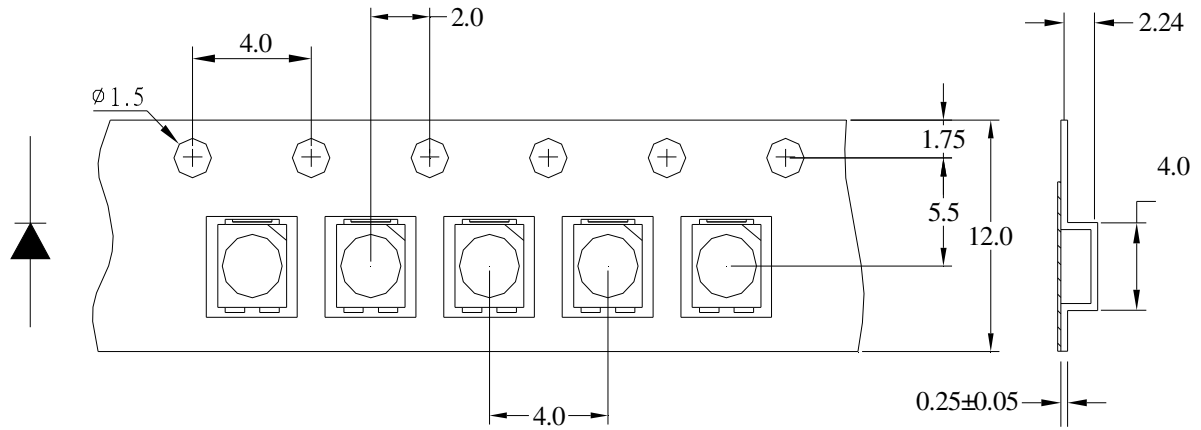

Figure 2

When populating boards in SMT production, there are basically no restrictions regarding the form of the pick and place nozzle, except that mechanical pressure on the surface of the resin must be prevented.

This is assured by choosing a pick and place nozzle which is larger than the LED's reflector area.

Dimensions for Tape



Dimensions for Reel

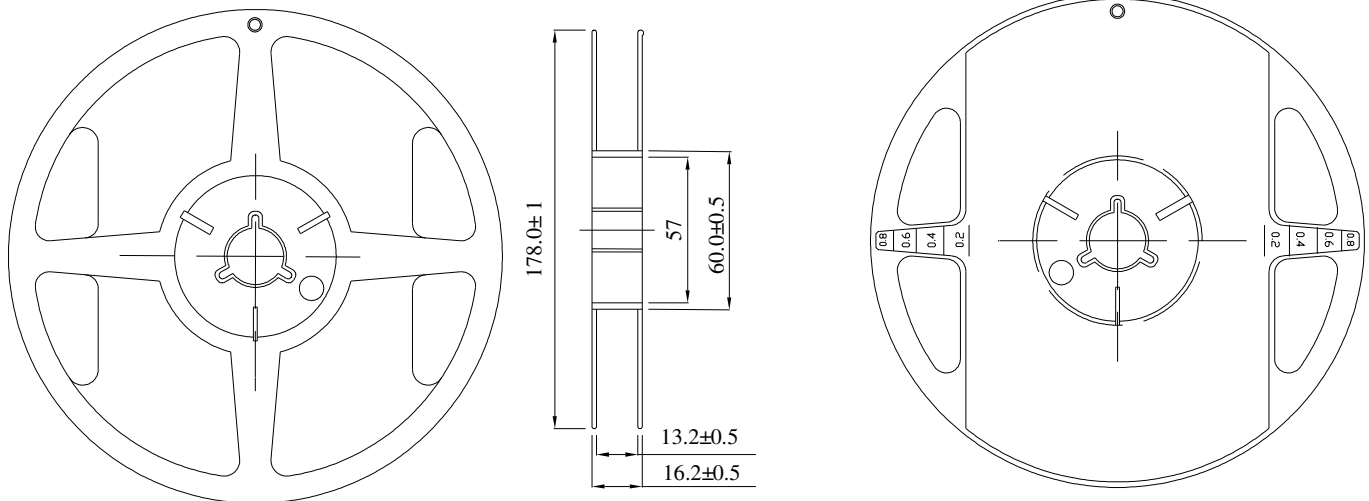

Notes:

1. All dimensions are in mm, tolerance is ± 2.0 mm unless otherwise noted.
2. Specifications are subject to change without notice.

Packing

REEL
QUANTITY: 2,000 PCS

LEDTECH ELECTRONICS CORP.
PART NO :LTXXXX-XX
Q'TY : PCS
LOT NO :XXXXXXXXXX
DATE :
BIN CODE:

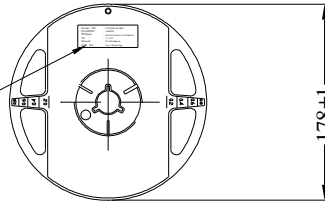

BAG
QUANTITY: 2,000 PCS

LEDTECH ELECTRONICS CORP.
PART NO :LTXXXX-XX
Q'TY : PCS
LOT NO :XXXXXXXXXX
DATE :
BIN CODE:

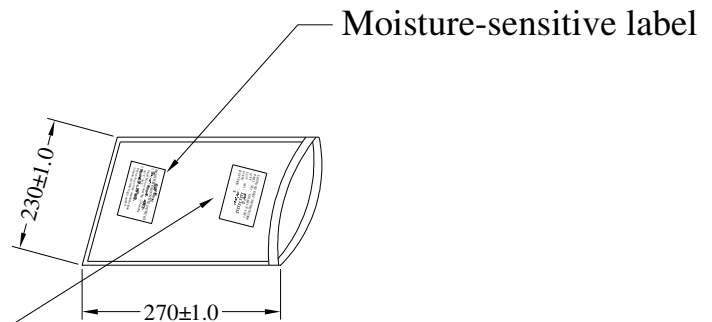

INSIDE BOX
QUANTITY: 4 BAGS
TOTAL: 8,000 PCS

LEDTECH ELECTRONICS CORP.
PART NO :LTXXXX-XX
Q'TY : PCS
LOT NO :XXXXXXXXXX
DATE :
BIN CODE:

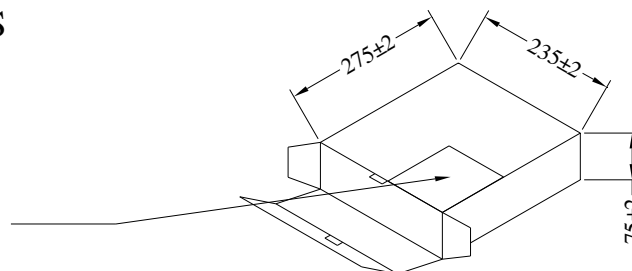

Notes:

- 1.All dimensions are in mm, tolerance is ± 2.0 mm unless otherwise noted.
- 2.Specifications are subject to change without notice.