

### Model Number

#### KCD2-EL

Sensor output interface terminal with lead breakage monitoring

### Features

- 1-channel terminal amplifier
- NAMUR sensor input
- DC 24 V supply voltage
- Standard interface for prevention of signal transmission errors
- Switching status indicator, yellow LED
- Lead breakage monitoring: The lead breakage monitoring can be disconnected by bridging terminals 1 and 3
- Short-circuit proof electronic output
- Low noise sensitivity
- Compact terminal housing
- Clips onto standard 35 mm rail to DIN EN 50 022
- Degree of protection IP20

### Technical data

#### Functional safety related parameters

MTTF <sub>d</sub>	1612 a
-------------------	--------

#### Indicators/operating means

LED yellow	switch output lead breakage: LED off, output locked
------------	--

#### Electrical specifications

Operating voltage	U <sub>B</sub>	10 ... 30 V DC
Ripple		≤ 10 %
Operating current		approx. 22 mA

#### Input

Connection	terminals 1+, 2-
Connectable sensor types	NAMUR
Pulse length/pulse interval	≥ 0.5 ms / ≥ 0.5 ms
Short-circuit current	approx. 8 mA
Sensor supply	8 V DC
Switching point	1.2 ... 2.1 mA hysteresis approx. 0.2 mA
Line fault detection	with
Trip value	1 kHz

#### Output

Connection	terminal 4-
Current	200 mA short-circuit protected
Transistor	NPN
Signal level	U <sub>B</sub> - 1.8V

#### Transfer characteristics

Mode of operation	NO contact
Switching frequency	1 kHz

#### Ambient conditions

Ambient temperature	-25 ... 70 °C (-13 ... 158 °F)
Storage temperature	-25 ... 85 °C (-13 ... 185 °F)

#### Mechanical specifications

Degree of protection	IP20
Connection	self-opening apparatus connection terminals, max. core cross-section 0.34 ... 2.5 mm <sup>2</sup>
Mass	60 g
Dimensions	20x60x40 (in mm)

#### Compliance with standards and directives

Directive conformity	
EMC Directive 2004/108/EC	EN 61326-1:2006
Standard conformity	
Noise immunity	EN 61326-1:2006
Degree of protection	EN 60529:2000

Dimensions

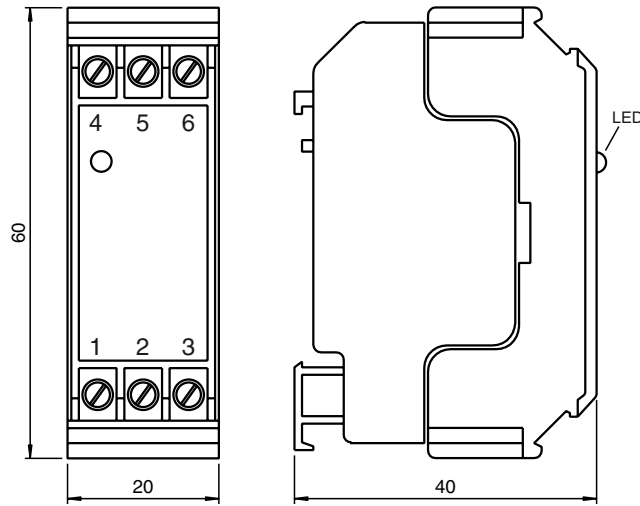

Electrical connection

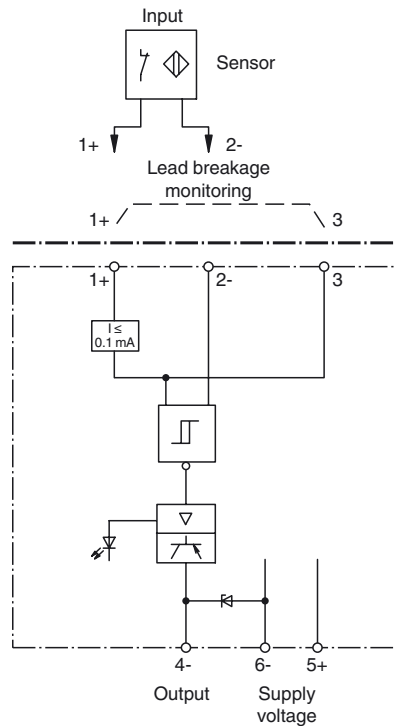

For lead break monitoring you must switch a resistance of 10 kOhm parallel to the contact locally, if you use a mechanical contact as an emitter.

Release date: 2014-10-22 16:45 Date of issue: 2014-10-22 018357\_eng.xml