



**Model Number**

**GL80-LAS/32/40a/98a**

Photoelectric slot sensor with 3-pin, M8 x 1 connector

**Features**

- High switching frequency
- High resolution
- Sturdy aluminum housing
- Light/dark switching
- Alignable housing
- Adjustable sensitivity

**Product information**

Photoelectric slot sensors with laser light can be used in applications with specific, demanding requirements and are ideal for highly precise and extremely fast applications. These eye-safe laser devices stand out through attributes that include particularly high switching frequencies of 10 kHz, maximum repeatability of 0.01 mm, automatic signal threshold adjustment, and detection of and/or light transmission through semi-transparent objects. In addition, the devices feature cross-talk protection, which enables devices to be installed adjacent to each other despite very high switching frequency.

**Dimensions**

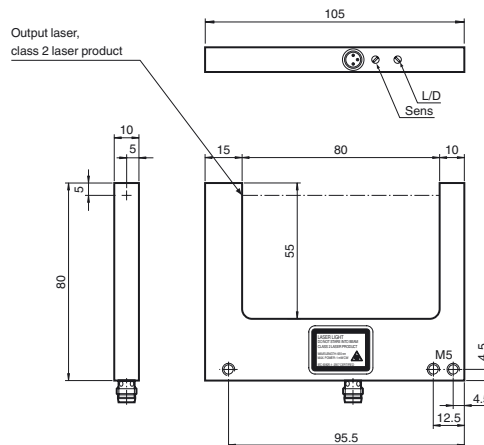

**Electrical connection**

Option: 32/40a

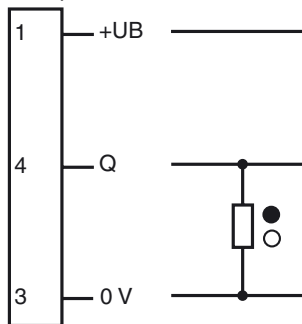

- = Light on
- = Dark on

**Pinout**



**Indicators/operating means**

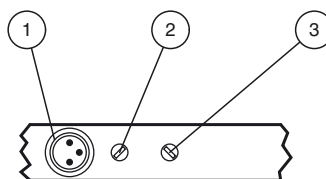

1	Functional display	yellow
2	Sensitivity adjuster	
3	Light-/dark switch	

Release date: 2013-08-26 10:29 Date of issue: 2013-09-11 190276\_eng.xml

Refer to "General Notes Relating to Pepperl+Fuchs Product Information".

**Technical data****General specifications**

Light source	laser diode
Light type	red
<b>Laser nominal ratings</b>	
Note	LASER LIGHT , DO NOT STARE INTO BEAM
Laser class	2
Wave length	650 nm
Beam divergence	2.6 mrad
Maximum optical power output	< 1 mW
Target size	0.05 mm
Fork width	80 mm
Ambient light limit	10000 Lux
Hysteresis	H < 0.02 mm

**Indicators/operating means**

Function display	LED yellow 4 x
Controls	Sensitivity adjuster, light/dark switch

**Electrical specifications**

Operating voltage	$U_B$	10 ... 30 V DC
No-load supply current	$I_0$	45 mA

**Output**

Switching type	light/dark on	
Signal output	1 PNP output, short-circuit protected, reverse polarity protected, open collector	
Switching voltage	max. 30 V DC	
Switching current	max. 200 mA	
Voltage drop	$U_d$	2.5 V ( 200 mA )
Switching frequency	f	10000 Hz
Response time		50 $\mu$ s

**Ambient conditions**

Ambient temperature	-10 ... 60 °C (14 ... 140 °F)
---------------------	-------------------------------

**Mechanical specifications**

Protection degree	IP65
Connection	M8 connector, 3-pin
<b>Material</b>	
Housing	black anodized aluminum
Optical face	glass
Installation	may be mounted in rows
Mass	30 g

**Compliance with standards and directives**

Directive conformity	EMC Directive 2004/108/EC
<b>Standard conformity</b>	
Product standard	EN 60947-5-2:2007 IEC 60947-5-2:2007
Laser class	IEC 60825-1:2007

**Approvals and certificates**

CCC approval	CCC approval / marking not required for products rated $\leq 36$ V
--------------	--

**Laser notice laser class 2**

- The irradiation can lead to irritation especially in a dark environment. Do not point at people!
- Caution: Do not look into the beam!
- Maintenance and repairs should only be carried out by authorized service personnel!
- Attach the device so that the warning is clearly visible and readable.
- Caution – Use of controls or adjustments or performance of procedures other than those specified herein may result in hazardous radiation exposure.

**Laserlabel****Accessories****V3-GM-2M-PUR**

Cable socket, M8, 3-pin, PUR cable

**V3-WM-2M-PUR**

Cable socket, M8, 3-pin, PUR cable

Other suitable accessories can be found at [www.pepperl-fuchs.com](http://www.pepperl-fuchs.com)