



**Model Number**

**MLV41-LL-IR-IO/95/136**

Fiber optic sensor  
with 4-pin, M8 x 1 connector

**Features**

- Robust fiber optic sensor for reliable operation under all conditions
- Adjustable continuous sensitivity
- Easy fiber optic installation with quick-action clamping lock
- Aluminum housing with high-quality Delta Seal coating
- IO-link interface for service and process data

**Product information**

The unique and extremely popular design of the MLV41 series enables it be mounted correctly in confined areas and offers all the functions that are normally only found on larger phototelectronic sensors. The MLV41 series comes with a range of functions. For example, highly visible status LEDs on the front and back, resistance to ambient light, crosstalk protection and universally applicable output stages that permit every possible switching logic and polarity to be realized. The enhanced resistance to ambient light ensures reliable operation even where modern energy-saving lamps with electronic ballasts are in use. The same applies where multiple devices are present, i.e. the use of a number of sensors in the same vicinity causes no problems.

**Dimensions**

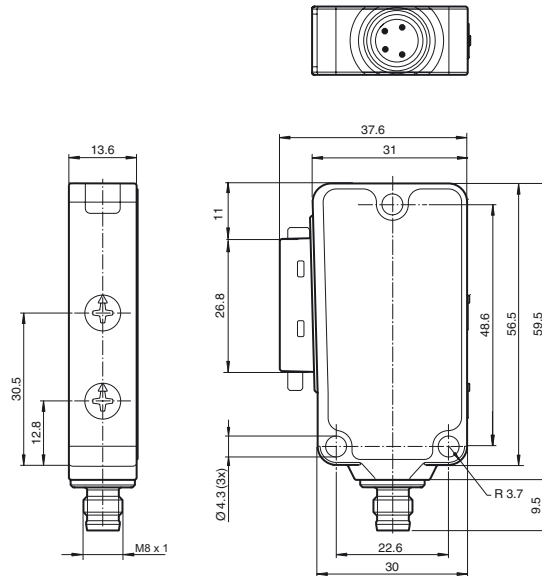

**Electrical connection**

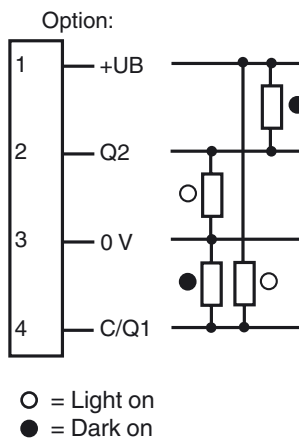

**Pinout**



**Indicators/operating means**

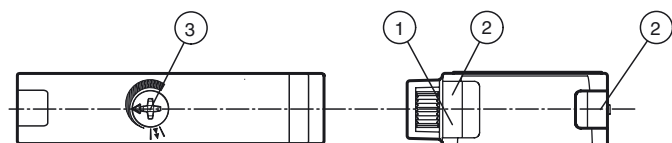

1	Operating display green	3	Sensing range adjuster / adjustment mode
2	Function display yellow		

Release date: 2013-12-12 13:08 Date of issue: 2013-12-12 2:49786\_eng.xml

**Technical data****General specifications**

Sensor range	on black (6 %): up to 55 mm on Kodak white, reflection factor 90% up to 160 mm with LLR 04-1.6-0.5-WC3 fiberoptic cable
Adjustment range	0 ... 160 mm on Kodak white, reflection factor 90%
Reference target	100 mm x 100 mm on Kodak white, reflection factor 90%
Light source	IREDD
Light type	modulated infrared light , 880 nm

**Functional safety related parameters**

MTTF <sub>d</sub>	770 a
Mission Time (T <sub>M</sub> )	20 a
Diagnostic Coverage (DC)	0 %

**Indicators/operating means**

Operation indicator	LED green, statically lit Power on , Undervoltage indicator: Green LED, pulsing (approx. 0.8 Hz) , short-circuit : LED green flashing (approx. 4 Hz) , IO link communication: green LED goes out briefly (1 Hz)
Function indicator	LED yellow, lights up with receiver lit ; flashes when falling short of the stability control
Control elements	sensitivity adjustment

**Electrical specifications**

Operating voltage	U <sub>B</sub>	10 ... 30 V DC
Ripple		max. 10 %
No-load supply current	I <sub>0</sub>	max. 40 mA

**Interface**

Interface type	IO-Link
Protocol	IO-Link V1.0
Mode	COM 2 (38.4 kBaud)

**Output**

Switching type	light/dark on	
Signal output	2 push-pull (4 in 1) outputs, complementary, short-circuit proof, reverse polarity protected	
Switching voltage	max. 30 V DC	
Switching current	max. 100 mA	
Voltage drop	U <sub>d</sub>	≤ 2.5 V DC
Switching frequency	f	1000 Hz
Response time		0.5 ms

**Ambient conditions**

Ambient temperature	-20 ... 60 °C (-4 ... 140 °F)
Storage temperature	-40 ... 75 °C (-40 ... 167 °F)

**Mechanical specifications**

Fiber optic adapter	04
Protection degree	IP67
Connection	M8 x 1 connector, 4-pin
Material	
Housing	aluminum , Delta-Seal coated
Optical face	Fiber optic connection
Connector	metal
Mass	50 g

**Compliance with standards and directives**

Directive conformity	
EMC Directive 2004/108/EC	EN 60947-5-2:2007
Standard conformity	
Product standard	EN 60947-5-2:2007 IEC 60947-5-2:2007

**Approvals and certificates**

UL approval	cULus Listed 57M3 (Only in association with UL Class 2 power supply; Type 1 enclosure)
CCC approval	CCC approval / marking not required for products rated ≤36 V

**IO link function**

The IO link operating mode is indicated by the green LED indicator with a short interruption (f = 1 Hz). IO link communication simultaneously provides process data (measurement data from the sensor) and access to requirement data.

The requirement data contains the following information:

**Identification:**

- Manufacturer information
- Product ID
- User-specific ID

**Device parameters:**

- Teach-in parameters
- Operating parameters

**Accessories****IO-Link-Master01-USB**

IO-Link master, supply via USB port or separate power supply, LED indicators, M12 plug for sensor connection

**IODD Interpreter DTM**

Software for the integration of IODDs in a frame application (e. g. PACTware)

**OMH-41**

Mounting bracket

**V31-WM-2M-PUR**

Female cordset, M8, 4-pin, PUR cable

**V31-GM-2M-PUR**

Female cordset, M8, 4-pin, PUR cable

**LCR 04-1,6-0,5-Z1**

Glass fiber optic - diffuse with PVC covering

**LLR 04-1,6-0,5-G(M6x30)**

Glass fiber optic - diffuse with metal silicone covering

**LCR 04-1,6-0,5-WC 3**

Glass fiber optic - diffuse with PVC covering

**LLR 04-1,6-0,5-W C3**

Glass fiber optic - diffuse with metal silicone covering

**LCE 04-1,6-1,0-Z1**

Glass fiber optic - thru-beam with PVC covering

**LCE 04-1,6-1,0 G**

Glass fiber optic - thru-beam with PVC covering

**LLE 04-1,6-1,0-G**

Glass fiber optic - thru-beam with metal silicone covering

**LCE 04-1,6-1,0-W C3**

Glass fiber optic - thru-beam with PVC covering

**LLE 04-1,6-1,0-W C3**

Glass fiber optic - thru-beam with metal silicone covering

Other suitable accessories can be found at [www.pepperl-fuchs.com](http://www.pepperl-fuchs.com)

- Configuration parameters
- Device commands

## Diagnostic messages and warnings

### Setting information

#### Detection range adjustment:

The detection range can be set via the rotary switch or the IO-Link.

#### Setting using the rotary switch:

If you would like to change the detection range on the sensor, turn:

- the rotary switch to the left to reduce the value.
- the rotary switch to the right to increase the value.

With the IO-Link, the set detection range the current rotary switch configuration is always assigned.

If the rotary switch is too far to the left or the right, perform the following:

Turn the potentiometer completely to the left until it stops. The LED will briefly flash green.

The assignment of the current rotary switch configuration to the detection range set via IO-Link is overridden.

Now set the desired detection range again.

#### Example application - manually reduce detection range:



The potentiometer has one position as shown here. The adjustable detection range is set via IO-Link to maximum. The rotary switch is too far to the left to set a considerably lower detection range for example.



Turn the potentiometer to the left until it stops to override the set value to this rotary switch configuration. The LED will briefly flash green.



Now set the desired detection range again.