



Model Number

GD18-S/GV18-S/25/102/115

Thru-beam sensor
with 2 m fixed cable

Features

- Efficient Line in a short M18 plastic housing for standard applications
- Very high detection range
- 4 LEDs indicator for 360° visibility
- Sidelookerversion
- DC voltage version

Product information

The GLV/GLK18 series sensors help improve the efficiency of machines and systems. The design of the M18 plastic housing, the connection technology, and sensor properties are highly standardized. Concentrating on the key sensor requirements has produced a robust and reliable product series for DC and AC/DC voltage systems without any over-engineering. The mounting set included in the scope of delivery and the optimized potentiometer design ensure fast assembly and easy configuration.

Dimensions

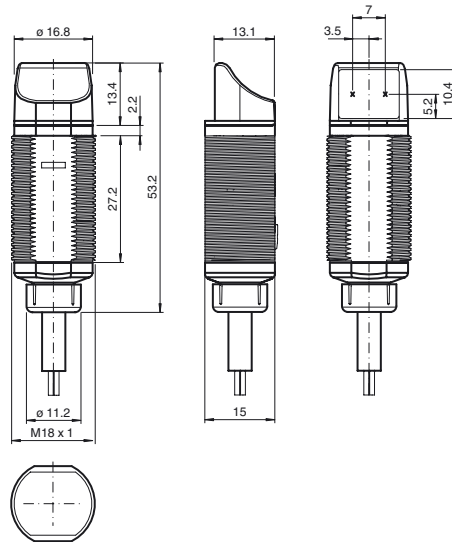

Electrical connection

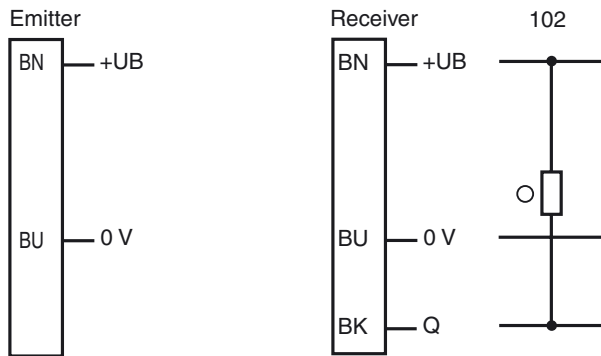

○ = Light on
● = Dark on

Indicators/operating means

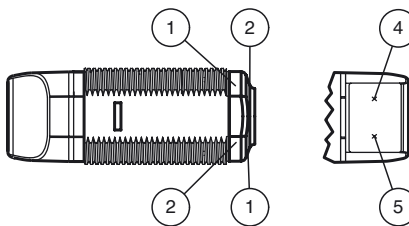

1	Operating display	green
2	Signal display	yellow
4	Emitter	
5	Receiver	

Release date: 2013-01-14 15:21 Date of issue: 2013-02-04 190529_eng.xml

Subject to modifications without notice

Pepperl+Fuchs Group
www.pepperl-fuchs.com

USA: +1 330 486 0001
fa-info@us.pepperl-fuchs.com

Germany: +49 621 776-4411
fa-info@pepperl-fuchs.com

Copyright Pepperl+Fuchs
Singapore: +65 6779 9091
fa-info@sg.pepperl-fuchs.com

Technical data**System components**

Emitter	GD18-S/115
Receiver	GV18-S/25/102/115

General specifications

Effective detection range	0 ... 12 m
Threshold detection range	17.5 m
Light source	LED
Light type	modulated visible red light , 640 nm
Diameter of the light spot	approx. 650 mm at 17.5 m
Angle of divergence	approx. 2 °
Optical face	lateral
Ambient light limit	30000 Lux

Functional safety related parameters

MTTF _d	630 a
Mission Time (T _M)	20 a
Diagnostic Coverage (DC)	0 %

Indicators/operating means

Operating display	LED green, statically lit Power on
Function display	Receiver: LED yellow, lights up when light beam is free, flashes when falling short of the stability control ; OFF when light beam is interrupted

Electrical specifications

Operating voltage	U _B	10 ... 30 V DC
No-load supply current	I ₀	< 20 mA

Output

Switching type	light on	
Signal output	1 NPN, short-circuit protected open collector	
Switching voltage	max. 30 V DC	
Switching current	max. 100 mA	
Voltage drop	U _d	≤ 1.5 V DC
Switching frequency	f	500 Hz
Response time		≤ 1 ms

Ambient conditions

Ambient temperature	-25 ... 60 °C (-13 ... 140 °F)
Storage temperature	-40 ... 70 °C (-40 ... 158 °F)

Mechanical specifications

Protection degree	IP67
Connection	2 m fixed cable
Material	
Housing	PC
Optical face	PMMA
Mass	approx. 75 g per device

Compliance with standards and directives

Standard conformity	
Product standard	EN 60947-5-2:2007 IEC 60947-5-2:2007

Approvals and certificates

Protection class	II, rated insulation voltage ≤ 250 V AC with pollution degree 1-2 according to IEC 60664-1
UL approval	cULus Listed, Class 2 Power Source, Type 1 enclosure
CCC approval	Products with a maximum operating voltage of ≤36 V do not bear a CCC marking because they do not require approval.

Accessories**CPZ18B03**

Mounting Bracket with swivel nut

BF 18

Mounting flange, 18 mm

BF 18-F

Mounting flange with dead stop, 18 mm

BF 5-30

Universal mounting bracket for cylindrical sensors with a diameter of 5 ... 30 mm

Other suitable accessories can be found at www.pepperl-fuchs.com

Curves/Diagrams

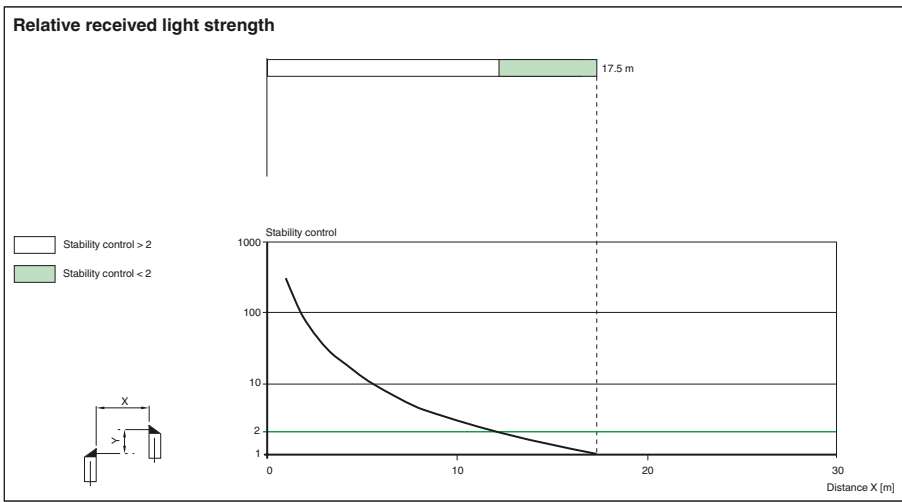
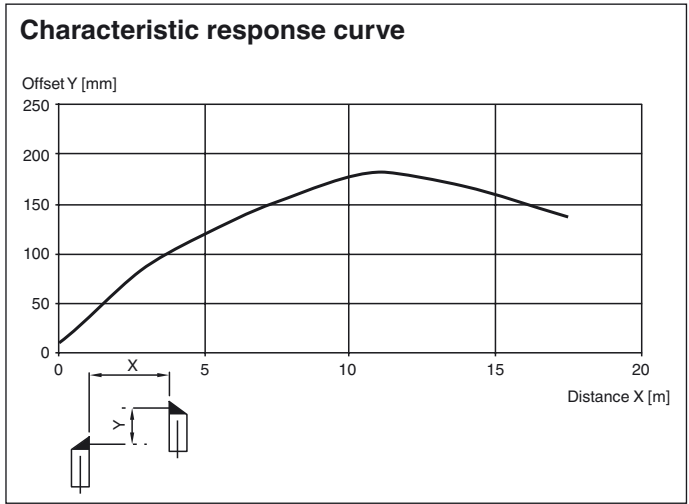

Release date: 2013-01-14 15:21 Date of issue: 2013-02-04 190529_eng.xml