



Model Number

IRI-KHD2-4.4M

Control interface unit with 4 relay outputs

Features

- Serial interface RS 232, RS 422, RS 485 or TTY
- 4 read heads can be connected
- Operating modes fixcode, protocol 3964R selectable with or without interpreter RK512
- 4 relay outputs
- 3 LEDs per read head for function indication
- LED for power on

Dimensions

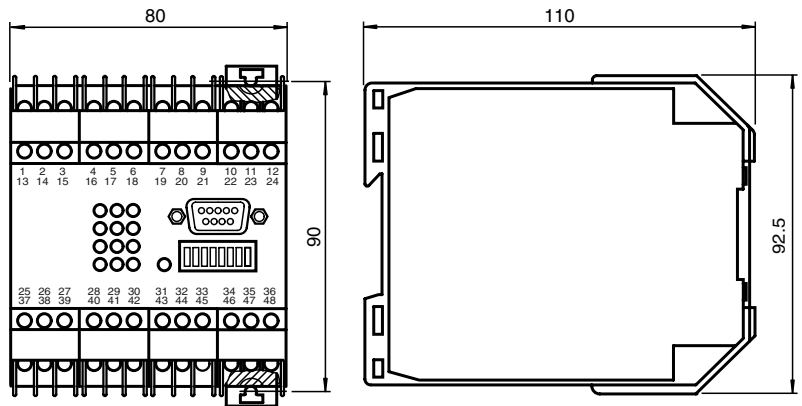

Electrical connection

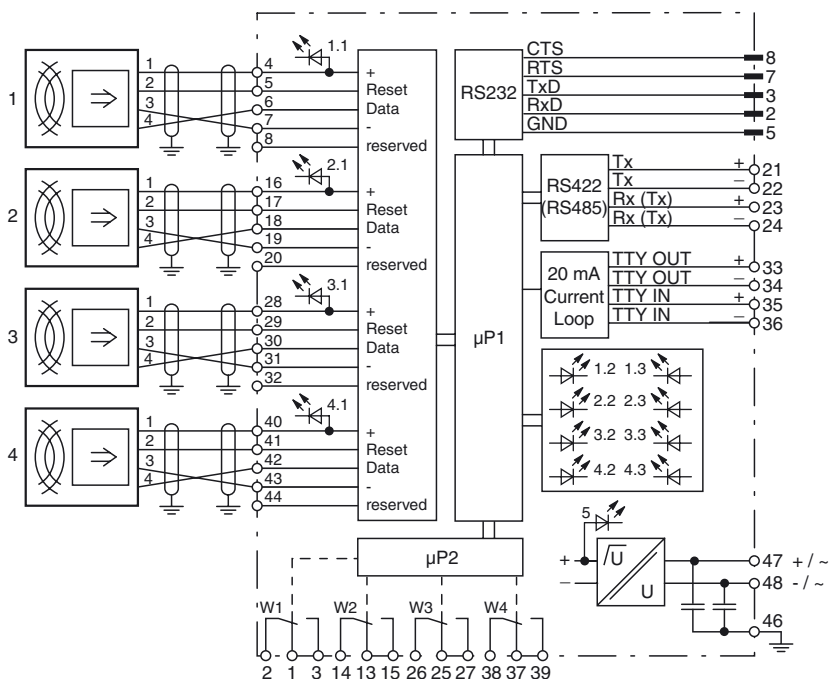

Indicating / Operating means

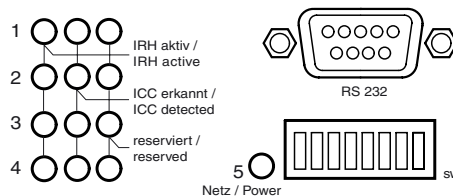

Release date: 2009-05-14 11:20 Date of issue: 2009-05-14 027505_ENG.xml

Technical data**General specifications**

Number of reading heads	max. 4
-------------------------	--------

Indicators/operating means

LED green	read head active (4 LEDs, 1 per head)
LED yellow	Code / data carrier detected (4 LEDs, 1 per head)
LED red	reserved (4 LEDs, 1 per head)
LED green 5	Power on
DIP-switch	setting the operating mode and interface

Electrical specifications

Rated operational voltage	U_e	18 ... 30 V DC , ripple 10 % _{SS}
Current consumption		170 mA
Power consumption	P_0	4 W
Supply		read head: 100 mA / 16.5 V DC \pm 5 %

Interface

Physical	RS 232, RS 422, RS 485, TTY (20 mA current loop)
Protocol	ASCII, 3964R with interpreter, 3964R without interpreter
Transfer rate	300 ; 600 ; 1200 ; 2400 ; 4800 ; 9600 ; 19200

Output

Output type	4 relays with changeover contacts
Test voltage	contact/coil 3000 V
Retention time/hold time	\geq 1 ms \pm 10 %
Contact loading	AC: 1 A/250 V, DC: 1 A/250 V
Lifetime	mechanical relay: 1 x 10 ⁵ vat max. contact loading 5 x 10 ⁷ operating cycles at 1 A / 30 V DC

Ambient conditions

Ambient temperature	-25 ... 70 °C (248 ... 343 K)
Storage temperature	-25 ... 85 °C (248 ... 358 K)
Climatic conditions	air humidity max. 75 %

Mechanical specifications

Protection degree	IP20 according to EN 60529
Connection	self-opening connection terminals, max. core cross-section 2 x 2.5 mm ² , 9-pin Sub-D built-in connector
Material	
Housing	Makrolon 6485
Construction type	K-system, 80 mm (4 TE)

Function

The control interface unit is connected via the serial interface to a higher-order control system.

The control interface unit receives the commands for reading the code carriers via this interface.

Up to 4 read heads can be connected to the control interface unit. The read heads can be queried either individually or through cyclic switching. When a code carrier is detected, a relay contact remains closed for a specified amount of time.

Using the DIP switches, it is possible to select between various operating modes on the control interface unit: fixcode, protocol 3964R with interpreter RK512, protocol 3964R without interpreter RK512 and 4-bit identification system.

With the "fixcode" operating mode, serial communication takes place via ASCII characters. All commands consist of multiple ASCII characters.

The control interface unit supports the computer coupling procedure 3964R, which was developed for programmable logic controllers; the commands are inserted into the telegram frame of the procedure. In addition, the RK512 interpreter can be used in combination with fetch telegrams.

The "4-bit-ID-system" operating mode is designed especially for simple control tasks. In this operating mode, activation via the serial interface is not necessary. The control interface unit cyclically activates all connected read heads.

The first 4 bits of a data carrier programmed for this operating mode are projected onto the relay outputs for an adjustable period of time. In this way, up to 16 different states can be coded.

With the relay outputs, pneumatic valves or comparable control devices can be directly connected. Thus, the path via a higher-order control system is made superfluous.

Software

Communication with the identification system is very easy with the demo program IDENT 2005. It shows the system options and simplifies commissioning.

The demo program is included in the scope of delivery.