

KEY FEATURES

- Power Module for PCB Mountable
- High Efficiency Up To 87%
- 2:1 Input Rang
- Six-sided Continuous Shield
- Standard Package
- Screw Terminal For Optional
- 3-Years Product Warranty

ELECTRICAL SPECIFICATIONS

Model No.	SK40-48-1.8S	SK40-48-2.5S	SK40-48-3.3S	SK40-48-5S	SK40-48-12S	SK40-48-15S	SK40-48-24S
Max. Output Wattage (W)	14.4W	20W	26.4W	40W	40W	40W	40W
Input Voltage (V.DC.)	48V (36-75V)	48V (36-75V)	48V (36-75V)	48V (36-75V)	48V (36-75V)	48V (36-75V)	48V (36-75V)
Output Voltage (V.DC.)	1.8V / 8000mA	2.5V / 8000mA	3.3V / 8000mA	5V / 8000mA	12V / 3333mA	15V / 2666mA	24V / 1666mA
Efficiency (%)	78%	82%	84%	86%	83%	83%	84%

Model No. (Single Output)	SK40-48-1.8S	SK40-48-2.5S	SK40-48-3.3S	SK40-48-5S	SK40-48-12S	SK40-48-15S	SK40-48-24S	
Max output wattage (W)	14.4W	20W	26.4W	40W	40W	40W	40W	
Input	Input Filter π type							
Output	Voltage (V.DC.)	1.8	2.5	3.3	5	12	15	24
	Voltage Accuracy	$\pm 2\%$						
	Current (mA) max	8000	8000	8000	8000	3333	2666	1666
	Line Regulation (LL-HL) (typ.)	$\pm 0.5\%$						
	Load Regulation (10-100%) (typ.)	$\pm 1\%$						
	Ripple (Vp-p)	50 mV max.			$\pm 1\%$ max.			
	Noise (Vp-p)	100 mV max.			$\pm 1\%$ max.			
	Trim	$\pm 10\%$						
Protection	Switching Frequency	400KHz						
	Over Power Protection	Works over 120% of rating and recovers automatically.						
	Over Voltage Protection	Zener diode clamp						
Isolation	Short Circuit Protection	Hiccup mode, auto-recovery						
	Voltage	1600 VDC.						
	Resistance	10^8 ohms						
Environment	Capacitance	1000 pF						
	Operating Temperature	-25°C...+70°C (with derating) (40°C full load with 18 CFM Air Flow)						
	Storage Temperature	-55°C...+105°C						
	Case Temperature	+100°C max.						
	Temperature Coefficient	$\pm 0.02\%$ Per°C						
	Humidity	95% RH						
	MTBF	>550,000 h @ 25°C (MIL-HDBK-217F)						
Physical	Dimension (L x W x H)	2.0 x 1.6 x 0.47 Inches (50.8 x 40.6 x 11.9 mm) Tolerance ± 0.5 mm						
	Case Material	Five-side shielded Aluminum with Non-Conductive base, Black Anodize						
	Weight	58 g						
	Cooling Method	Free-air convection						

1. All specifications valid at normal input voltage, full load and +25°C after warm-up time unless otherwise stated.

2. Ripple & Noise are measured at 20MHz of bandwidth with 0.1 μ F & 47 μ F parallel capacitor.

OUTPUT NOISE

The output noise is measured with 10 μ F tantalum capacitor and 1 μ F ceramic capacitor across output.

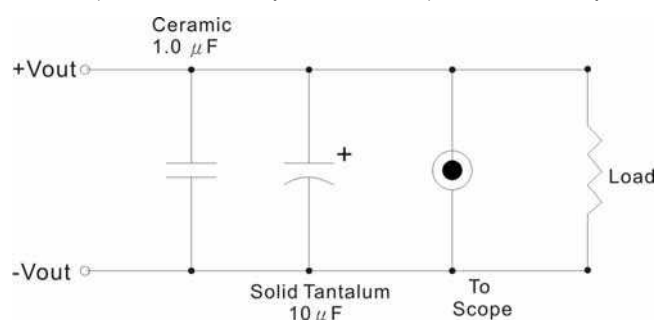

SK40 SERIES

30 Watts

MECHANICAL DIMENSION (Top View)

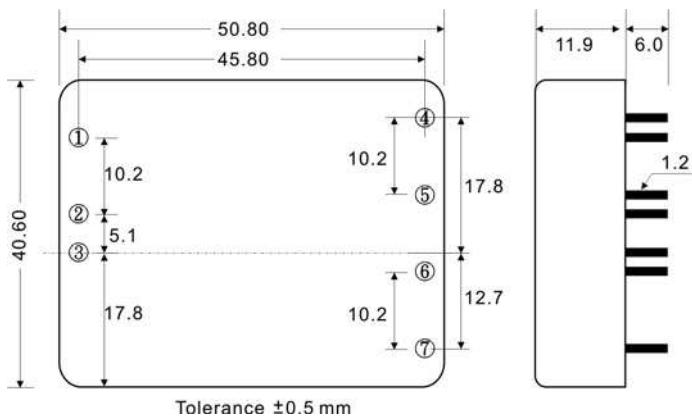

PIN#	Single
1	CTRL
2	-DC IN
3	+DC IN
4	TRIM
5	-DC OUT
6	+DC OUT
7	NO PIN

DERATING

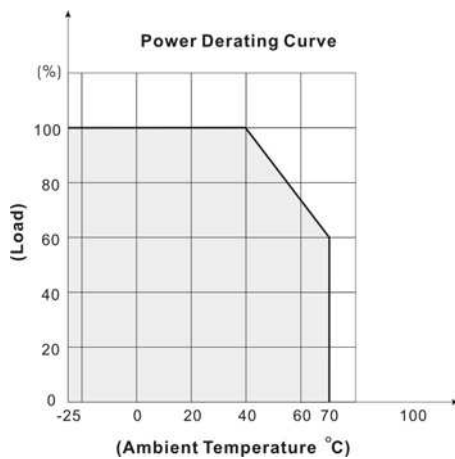

REMOTE ON/OFF CONTROL & TRIM

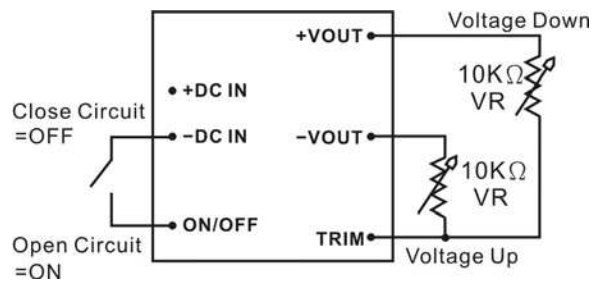

BLOCK DIAGRAM

Output Voltage (V.DC) : 1.8V, 2.5V, 3.3V, 5V

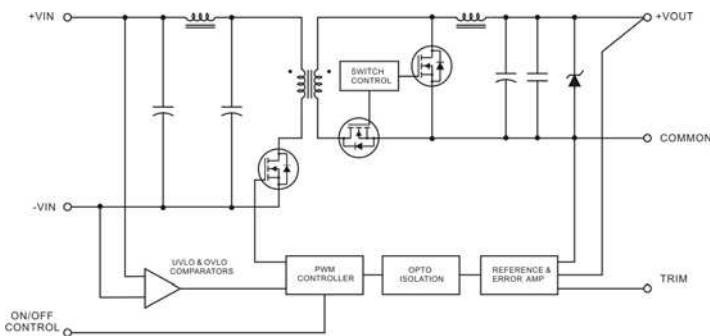

Output Voltage (V.DC) : 12V, 15V, 24V

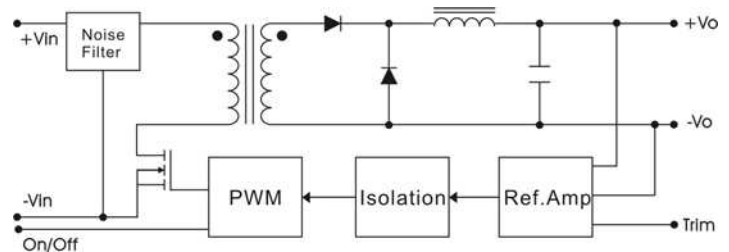

SK40 SERIES
30 Watts
SCREW TERMINAL
SK40-A2

PIN#	Single
1	CTRL
2	-DC IN
3	+DC IN
4.	TRIM
5	-DC OUT
6	NO CONNECT
7	+DC OUT
8	NO CONNECT

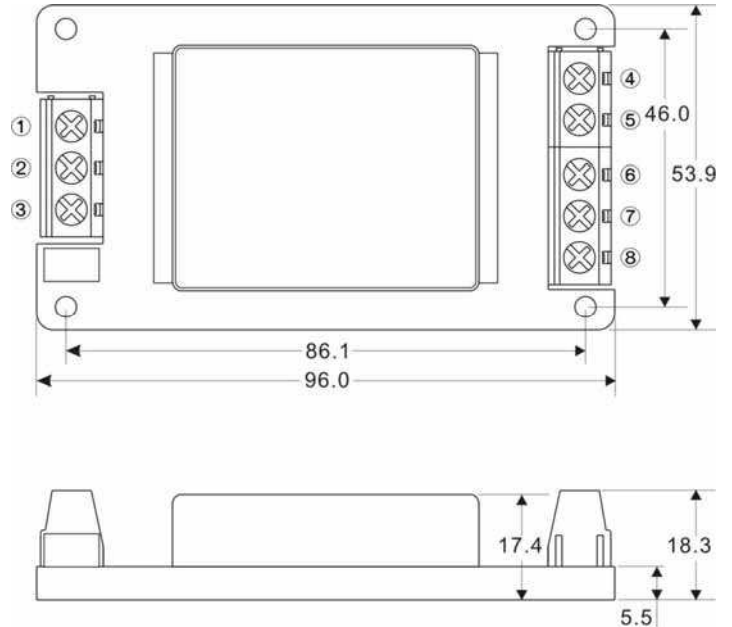
SK40-A5

PIN#	Single
1	CTRL
2	-DC IN
3	+DC IN
4.	TRIM
5	-DC OUT
6	NO CONNECT
7	+DC OUT
8	NO CONNECT

