

Powered RS-232 2-Port PCIe Card

User Manual

Ver. 1.00

**All brand names and trademarks are properties of their
respective owners.**

Contents:

Chapter 1: Introduction	3
1.1 Product Introduction	3
1.2 Features.....	4
1.3 System Requirements	4
1.4 Package Contents.....	5
Chapter 2: Getting Started	5
2.1 Hardware Installation	5
2.2 Jumper Settings.....	6
2.3 Driver Installation.....	9
2.3.1 Installation for Windows XP/Vista/7	9
2.3.2 Installation for Linux 2.4.x/2.6.x	10
2.3.3 Installation for Windows CE.....	11

Chapter 1: Introduction

1.1 Product Introduction

RS-232 I/O series, a line of PCI Express Multi-port Serial Communication Board, is designed to meet PCI Express Base Specification Ver1.1 (Compliant with PCI Express General 2 Specification). It can be installed in virtually any available PC system and compatible with all major operating systems. Users do not need to manually set jumpers to configure I/O addresses and IRQ locations. Besides this board supports 5VDC or 12DV of power from each serial port via 1/4/8/9 pin output. It's convenient for users connecting serial devices without addition external power supply.

This board offer independent serial ports for connecting terminals, modems, printers, scanners, cash registers, bar code readers, keypads, numeric displays, electrical scales, data acquisition equipment, and other serial devices for the PC and compatible systems. This board offers a reliable and high performance solution for serial multi-port communications.

1.2 Features

- Compliant with PCI Express Base Specification 1.1
- Supports x1, x2, x4, x8, x16 (lane) PCI Express Bus connector keys
- Support 2 x UART serial ports
- Built-in 16C950 compatible UART
- 128-byte deep transmit/receive FIFOs
- Data transfer rate up to 230400bps
- Optional RS-232 signal or power output to serial device
- Provides 5VDC or 12VDC power output via pin 1/4/8/9
- ±15KV ESD protection on all signal pins
- Plug-n-Play, I/O address and IRQ assigned by BIOS
- Support Windows XP/Vista/7, Linux, Window CE

1.3 System Requirements

- Windows® XP/Vista/7 (32/64 bit), Linux, Windows CE
- One available PCI Express slot

1.4 Package Contents

- 1 x Powered RS-232 2-Port PCIe Card
- 1 x Driver CD
- 1 x User Manual
- 1 x Fan Out Cable

Note: Contents may vary depending on country/market.

Chapter 2: Getting Started

2.1 Hardware Installation

1. Turn off the power to your computer.
2. Unplug the power cord and remove your computer's cover.
3. Remove the slot bracket from an available PCIe slot.
4. To install the card, carefully align the card's bus connector with the selected PCIe slot on the motherboard. Push the board down firmly.
5. Replace the slot bracket's holding screw to secure the card.
6. Replace the computer cover and reconnect the power cord.

Power for the Powered RS-232 DB9 connectors are supplied from 4-pin connector located on the PCB. This connectors allows a PC CD-ROM type power supply connector to provide the higher currents required by the power peripherals.

In order to get efficient intake current output, there is one set of 4-pin power connector designed on the board. The 4-pin power set draws both +12VDC and +5VDC power output for powered RS-232 device using.

Note: If system's power supply can not provide the efficient power to serial devices, it will cause your PC system unstable or unexpected reboot.

2.2 Jumper Settings





This powered RS-232 board supports DC power output to device feature. You can select +5V or +12VDC power output to serial device over DB 1st, 4th, 8th and 9th pin. Please follow the jumper settings before using each COM port.











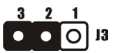























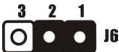

CAUTION

1. Be sure to confirm your serial device power voltage sourcing and pin number to prevent any further problem.
2. Before plugging this board into your system, please carefully check the power output jumper setting and hardware installation steps to prevent any damages.
3. Wrong operating damages connected serial device.
4. DO NOT cross the jumper settings over different pin define.

You can read below silkscreen print on the PCB. Each COM port has four jumper settings for the 1/4/8/9 pin for DB9 male connector. You can select standard RS-232 signal (system default), +5VDC, or +12VDC power output on the assigned pin.

COM 1 Port – 1 st Pin				
Normal(DCD)	5V		12V	
				

COM 1 Port – 4 th Pin				
Normal(DTR)	5V		12V	
				
COM 1 Port – 8 th Pin				
Normal(CTS)	5V		12V	
				
COM 1 Port – 9 th Pin				
Normal(RI)	5V		12V	
				
COM 2 Port – 1 st Pin				
Normal(DCD)	5V		12V	
				
COM 2 Port – 4 th Pin				
Normal(DTR)	5V		12V	
				

COM 2 Port – 8 th Pin				
Normal(CTS)	5V		12V	
				
COM 2 Port – 9 th Pin				
Normal(RI)	5V		12V	
				

Note:

- 1. System default setting is normal mode, standard RS-232 pin define.*
- 2. No described pins mean standard RS-232 definition.*

2.3 Driver Installation

2.3.1 Installation for Windows XP/Vista/7

1. Insert the provided CD into your disk drive. The CD-ROM will start automatically. The following screen will show up and please click **“Install Driver”**.



Note: If the install program doesn't run automatically, please locate and double-click on the **Autorun.exe** file in the CD to launch the install program.

2. Please click “**RS-232 PCIe Card**” to start the installation.



3. Follow the instructions on screen to install the driver.

2.3.2 Installation for Linux 2.4.x/2.6.x

Please refer to the installation guide and driver for Linux 2.4.x & 2.6.x

operation system installation within the folder located in the CD driver.

:\Driver\PCIE\Linux

2.3.3 Installation for Windows CE

Please refer to the installation guide and driver for Windows CE 5.0 operation system installation within the folder located in the CD driver.

:\Driver\PCIE\Windows CE