

2 W High Gain Power Amplifier for Cellular Infrastructure

InGaP GaAs HBT

The MMZ25333B is a versatile 3-stage power amplifier targeted at driver and pre-driver applications for macro and micro base stations and final-stage applications for small cells. Its versatile design allows operation in any frequency band from 1500 to 2700 MHz providing gain of more than 40 dB. The device operates off a 5 V supply, and its bias currents and portions of the matching networks are adjustable for optimum performance in any specific application. It is housed in a QFN 4 × 4 surface mount package.

- Typical PA Driver Performance: $V_{CC1} = V_{CC2} = V_{CC3} = V_{BIAS} = 5$ Vdc, $I_{CQ} = 265$ mA

Frequency	P _{out} (dBm)	G _{ps} (dB)	ACPR (dBc)	I _{CC} Total	Test Signal
2600 MHz	18.0	42.6	-50.8	296	W-CDMA
2140 MHz	17.0	43.7	-50.7	293	W-CDMA

- Typical Output PA Performance: $V_{CC1} = V_{CC2} = V_{CC3} = V_{BIAS} = 5$ Vdc, $I_{CQ} = 450$ mA

Frequency	P _{out} (dBm)	G _{ps} (dB)	ACPR (dBc)	I _{CC} Total	Test Signal
2600 MHz	22.2	42.7	-48.0	501	W-CDMA

MMZ25333BT1

**1500–2700 MHz, 44.2 dB, 31.7 dBm
 InGaP HBT LINEAR AMPLIFIER**

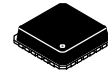

QFN 4 × 4

Features

- P1dB: up to 33 dBm
- Gain: More than 40 dB
- 5 V Supply
- Excellent Linearity
- High Efficiency
- Single-ended Power Detector
- Band Tunable
- In Tape and Reel. T1 Suffix = 1,000 Units, 12 mm Tape Width, 7-inch Reel.

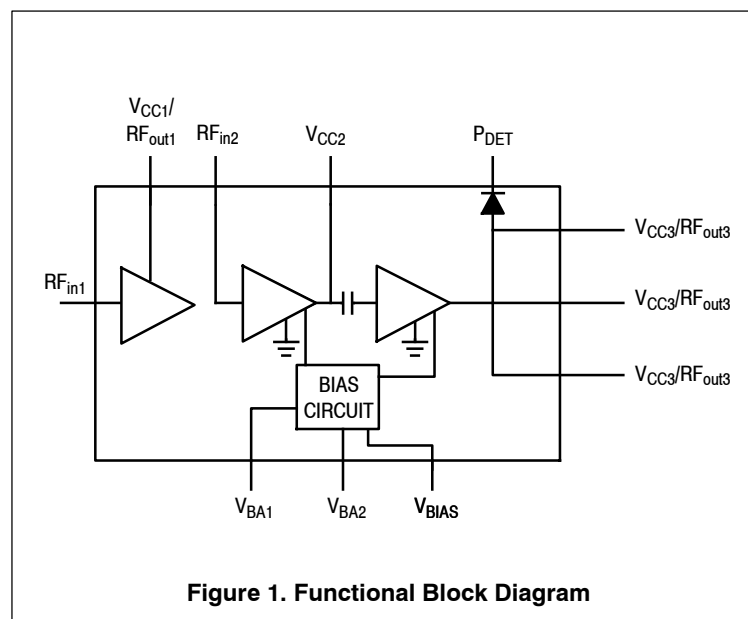

Figure 1. Functional Block Diagram

Table 1. Maximum Ratings

Rating	Symbol	Value	Unit
Supply Voltage	V_{CC}	6	V
Supply Current	I_{CC1} I_{CC2} I_{CC3}	66 240 960	mA
RF Input Power	P_{in}	10	dBm
Storage Temperature Range	T_{stg}	-65 to +150	°C
Junction Temperature	T_J	175	°C

Table 2. Thermal Characteristics

Characteristic	Symbol	Value (1)	Unit
Thermal Resistance, Junction to Case Case Temperature 104°C, $V_{CC1} = V_{CC2} = V_{CC3} = V_{BIAS} = 5$ Vdc	$R_{\theta JC}$		°C/W
Stage 1		28	
Stage 2		68	
Stage 3		21	

Table 3. Electrical Characteristics ($V_{CC1} = V_{CC2} = V_{CC3} = V_{BIAS} = 5$ Vdc, 2600 MHz, $T_A = 25^\circ\text{C}$, 50 ohm system, in Freescale PA Driver Application Circuit)

Characteristic	Symbol	Min	Typ	Max	Unit
Small-Signal Gain (S21)	G_p	40.4	43.0	—	dB
Input Return Loss (S11)	IRL	—	-12.2	—	dB
Output Return Loss (S22)	ORL	—	-7.1	—	dB
Power Output @ 1dB Compression	P1dB	—	32.0	—	dBm
Third Order Output Intercept Point, Two-Tone CW	OIP3	—	42.8	—	dBm
Total Supply Current ($I_{CC1} + I_{CC2} + I_{CC3} + I_{BIAS}$)	I_{CQ}	244	265	284	mA
Supply Voltage	V_{CC}	—	5	—	V

1. Refer to AN1955, *Thermal Measurement Methodology of RF Power Amplifiers*. Go to <http://www.freescale.com/rf>.
Select Documentation/Application Notes - AN1955.

Table 4. ESD Protection Characteristics

Test Methodology	Class
Human Body Model (per JESD22-A114)	1C
Machine Model (per EIA/JESD22-A115)	A
Charge Device Model (per JESD22-C101)	IV

Table 5. Moisture Sensitivity Level

Test Methodology	Rating	Package Peak Temperature	Unit
Per JESD22-A113, IPC/JEDEC J-STD-020	1	260	°C

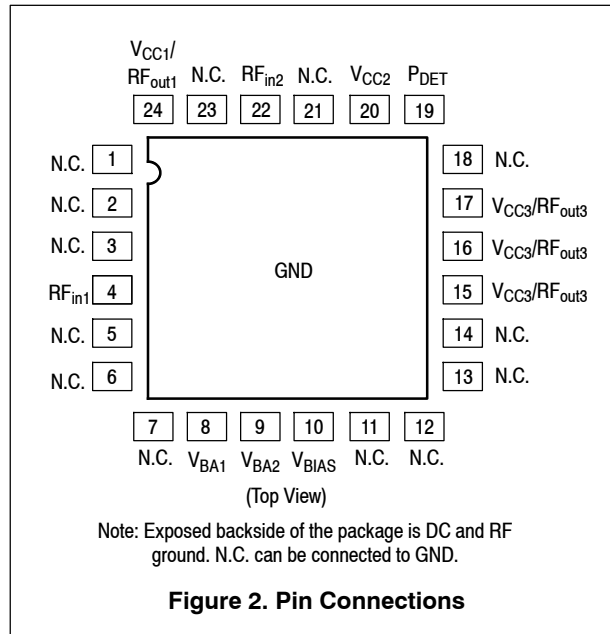

50 OHM APPLICATION CIRCUIT: 2500–2700 MHz

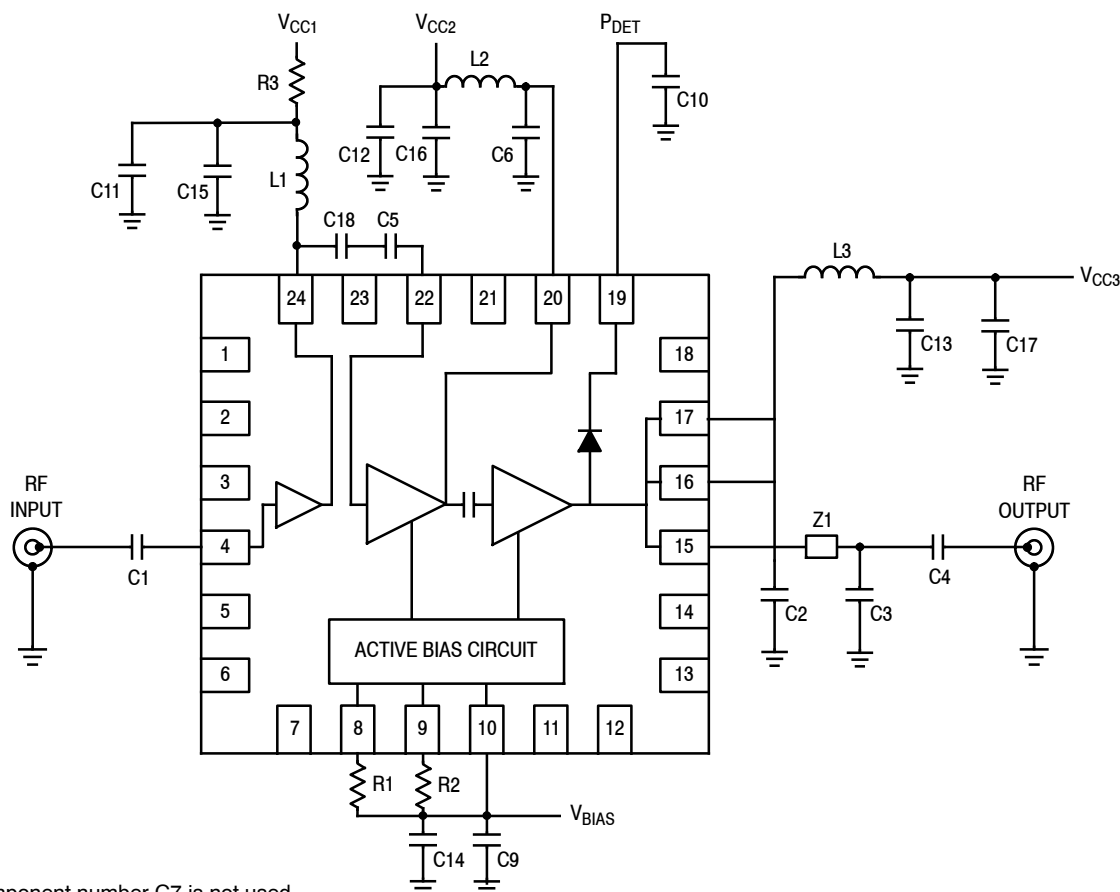

Note: Component number C7 is not used.

Z1 0.143" x 0.022" Microstrip

Figure 3. MMZ2533BT1 Test Circuit Schematic

Table 6. MMZ2533BT1 Test Circuit Component Designations and Values

Part	Description	Part Number	Manufacturer
C1, C4, C5	22 pF Chip Capacitors	04023J220BBS	AVX
C2	2 pF Chip Capacitor	04023J2R0BBS	AVX
C3	1.5 pF Chip Capacitor	04023J1R5BBS	AVX
C6	7.5 pF Chip Capacitor	04023J7R5BBS	AVX
C8	Component Not Placed		
C9, C11, C12, C13	1000 pF Chip Capacitors	GCM155R71E103KA37	Murata
C10	470 pF Chip Capacitor	GRM1555C1H471JA01	Murata
C14, C16	1 μ F Chip Capacitors	GRM188R61A105KE15	Murata
C15	0.01 μ F Chip Capacitor	C0603C103J5RAC	Kemet
C17	4.7 μ F Chip Capacitor	GRM188R60J475KE19	Murata
C18	2.2 pF Chip Capacitor	04023J12R2BBS	AVX
L1	56 nH Chip Inductor	0603HC-56NX	Coilcraft
L2	10 nH Chip Inductor	0603HC-10NX	Coilcraft
L3	6.8 nH Chip Inductor	0603HC-6N8X	Coilcraft
L4	Component Not Placed		
R1 ($I_{CQ} = 265$ mA)	1.8 k Ω , 1/16 W Chip Resistor	CR05-182J-B	Kyocera
R2 ($I_{CQ} = 265$ mA)	680 Ω , 1/16 W Chip Resistor	CR05-681J-B	Kyocera
R1 ($I_{CQ} = 450$ mA)	1.2 k Ω , 1/16 W Chip Resistor	CR05-122J-B	Kyocera
R2 ($I_{CQ} = 450$ mA)	330 Ω , 1/16 W Chip Resistor	CR05-331J-B	Kyocera
R3	27 Ω , 1/10 W Chip Resistor	CR10-270J-T	Kyocera
PCB	Rogers RO4350B, 0.010", $\epsilon_r = 3.66$	M70506	MTL

Note: Component numbers C8 and L4 are labeled on board but not placed.

MMZ2533BT1

50 OHM APPLICATION CIRCUIT: 2500–2700 MHz

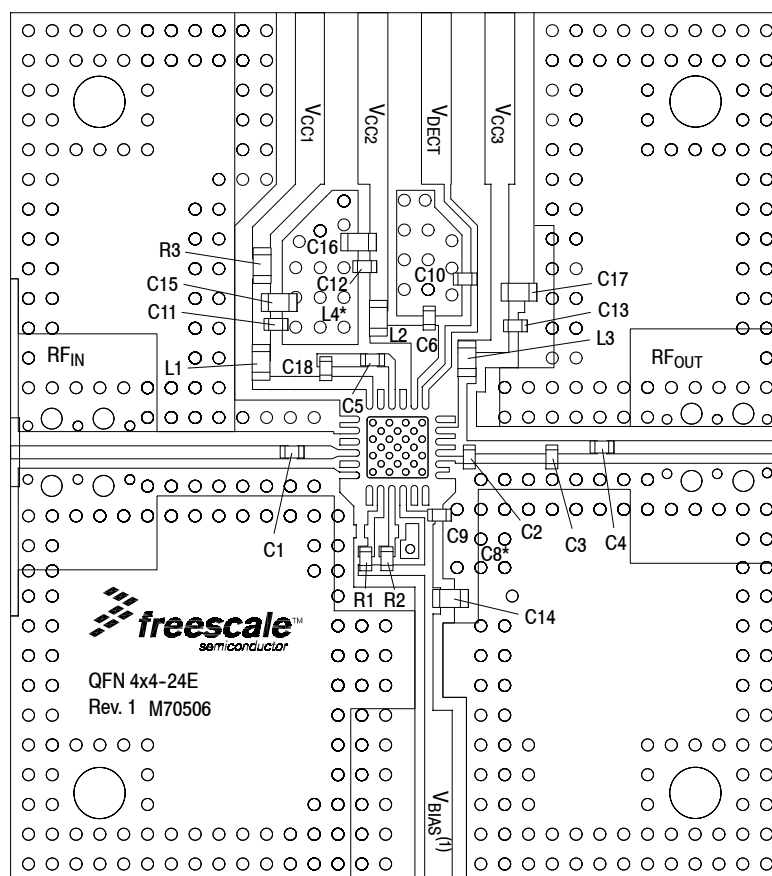

PCB actual size: 1.3" × 1.46".

(1) VBIAS [Board] supplies V_{BA1}, V_{BA2} and V_{BIAS} [Device].

Note: Component number C7 is not used. Component numbers C8* and L4* are labeled on board but not placed.

Figure 4. MMZ25333BT1 Test Circuit Component Layout

Table 6. MMZ25333BT1 Test Circuit Component Designations and Values

Part	Description	Part Number	Manufacturer
C1, C4, C5	22 pF Chip Capacitors	04023J220BBS	AVX
C2	2 pF Chip Capacitor	04023J2R0BBS	AVX
C3	1.5 pF Chip Capacitor	04023J1R5BBS	AVX
C6	7.5 pF Chip Capacitor	04023J7R5BBS	AVX
C8	Component Not Placed		
C9, C11, C12, C13	1000 pF Chip Capacitors	GCM155R71E103KA37	Murata
C10	470 pF Chip Capacitor	GRM1555C1H471JA01	Murata
C14, C16	1 μF Chip Capacitors	GRM188R61A105KE15	Murata
C15	0.01 μF Chip Capacitor	C0603C103J5RAC	Kemet
C17	4.7 μF Chip Capacitor	GRM188R60J475KE19	Murata
C18	2.2 pF Chip Capacitor	04023J12R2BBS	AVX
L1	56 nH Chip Inductor	0603HC-56NX	Coilcraft
L2	10 nH Chip Inductor	0603HC-10NX	Coilcraft
L3	6.8 nH Chip Inductor	0603HC-6N8X	Coilcraft
L4	Component Not Placed		
R1 (I _{CQ} = 265 mA)	1.8 kΩ, 1/16 W Chip Resistor	CR05-182J-B	Kyocera
R2 (I _{CQ} = 265 mA)	680 Ω, 1/16 W Chip Resistor	CR05-681J-B	Kyocera
R1 (I _{CQ} = 450 mA)	1.2 kΩ, 1/16 W Chip Resistor	CR05-122J-B	Kyocera
R2 (I _{CQ} = 450 mA)	330 Ω, 1/16 W Chip Resistor	CR05-331J-B	Kyocera
R3	27 Ω, 1/10 W Chip Resistor	CR10-270J-T	Kyocera
PCB	Rogers RO4350B, 0.010", ε _r = 3.66	M70506	MTL

(Test Circuit Component Designations and Values table repeated for reference.)

MMZ25333BT1

50 OHM TYPICAL CHARACTERISTICS: 2500–2700 MHz, $I_{CQ} = 265 \text{ mA}$

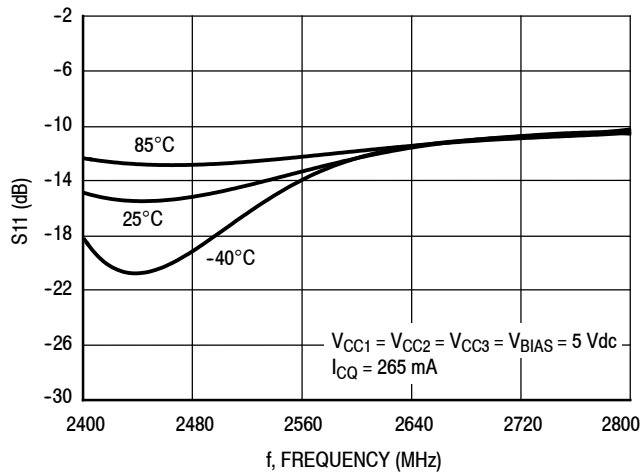

Figure 5. S11 versus Frequency versus Temperature

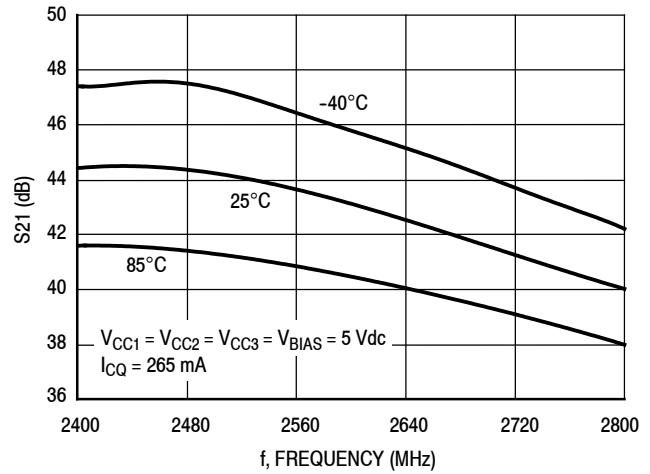

Figure 6. S21 versus Frequency versus Temperature

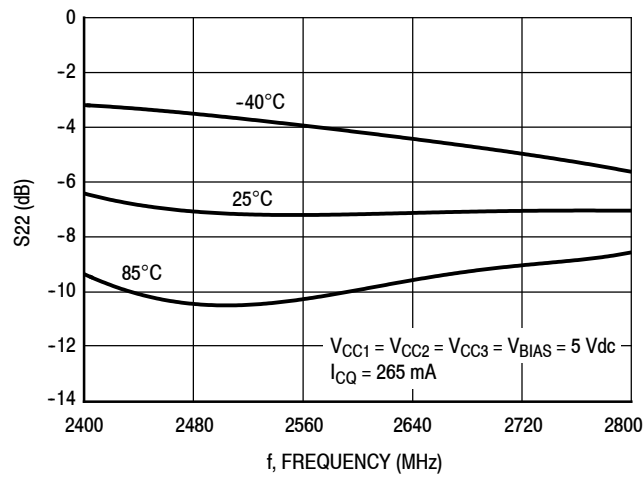

Figure 7. S22 versus Frequency versus Temperature

50 OHM TYPICAL CHARACTERISTICS: 2500–2700 MHz, $I_{CQ} = 265$ mA

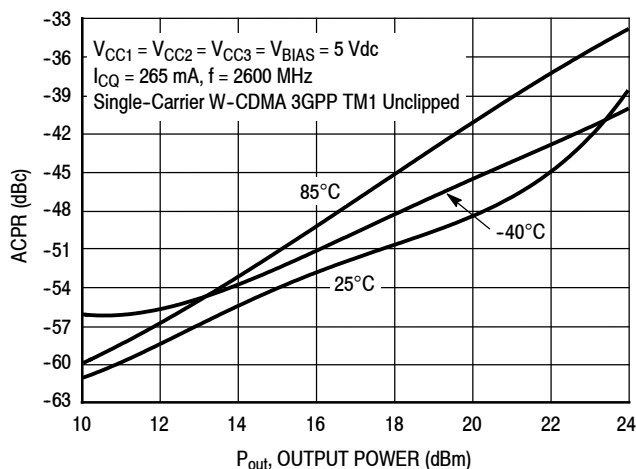

Figure 8. ACPR versus Output Power versus Temperature

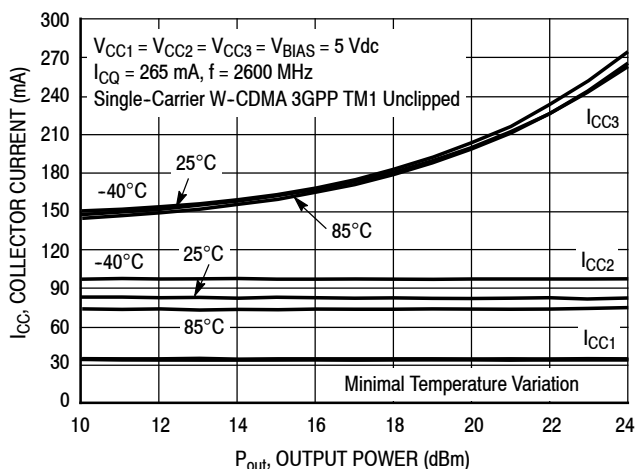

Figure 9. Stage Collector Current versus Output Power versus Temperature

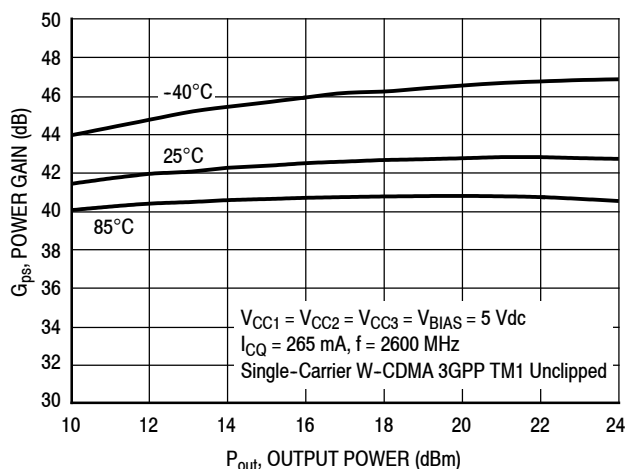

Figure 10. Power Gain versus Output Power versus Temperature

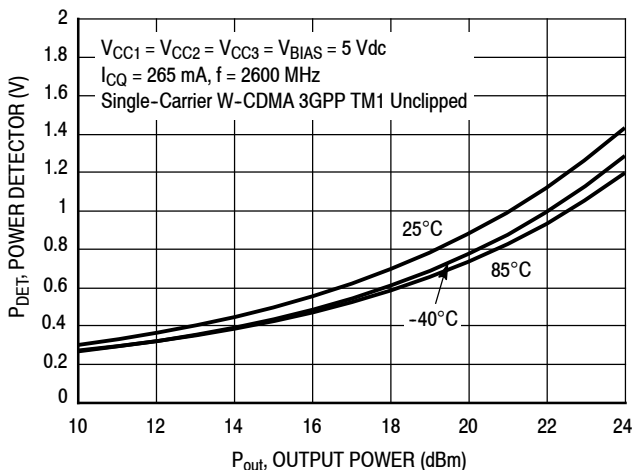

Figure 11. Power Detector versus Output Power versus Temperature

50 OHM TYPICAL CHARACTERISTICS: 2500–2700 MHz, $I_{CQ} = 450 \text{ mA}$

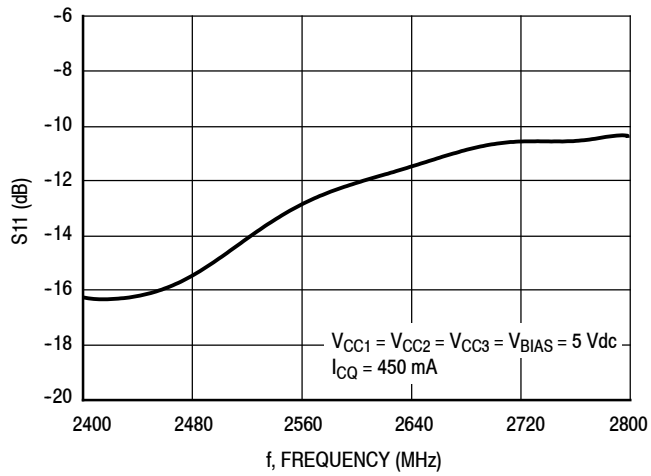

Figure 12. S11 versus Frequency

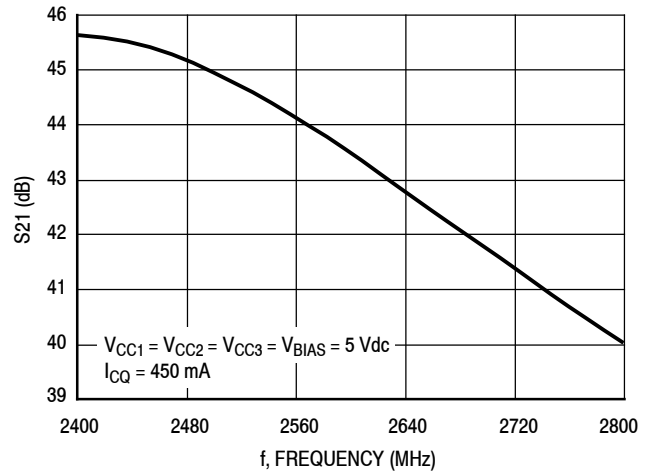

Figure 13. S21 versus Frequency

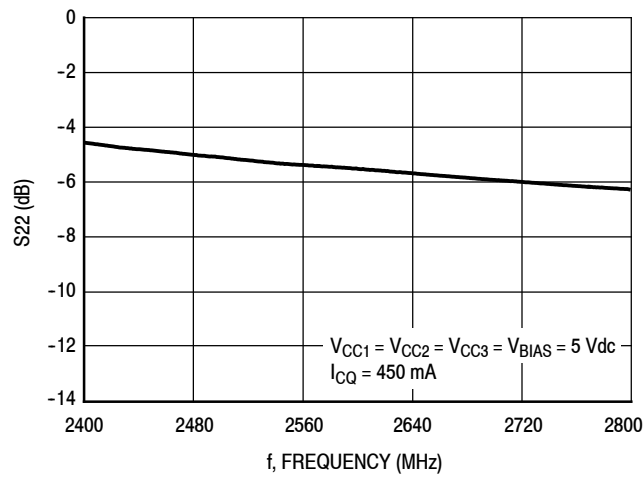

Figure 14. S22 versus Frequency

50 OHM TYPICAL CHARACTERISTICS: 2500–2700 MHz, $I_{CQ} = 450$ mA

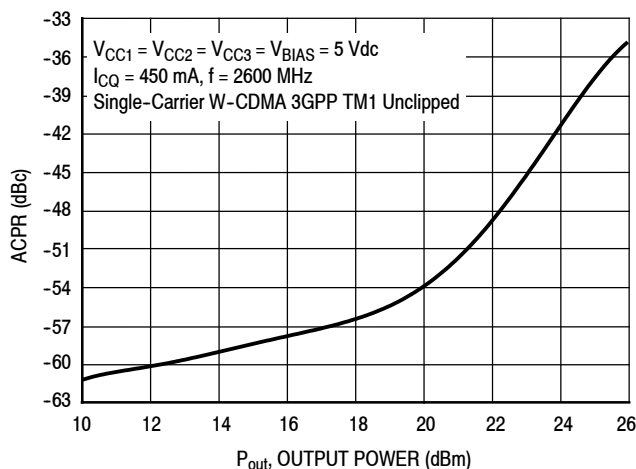

Figure 15. ACPR versus Output Power

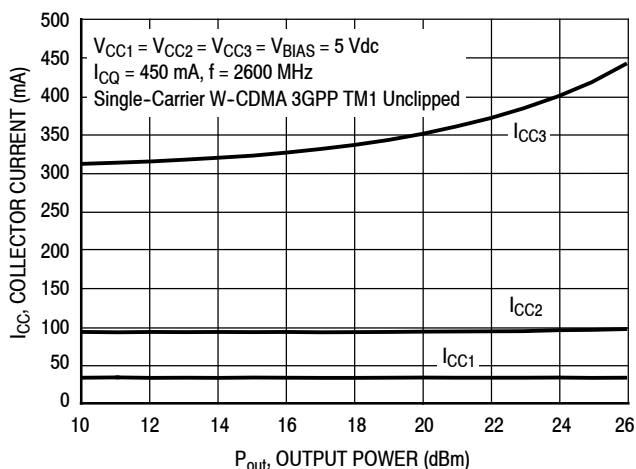

Figure 16. Stage Collector Current versus Output Power

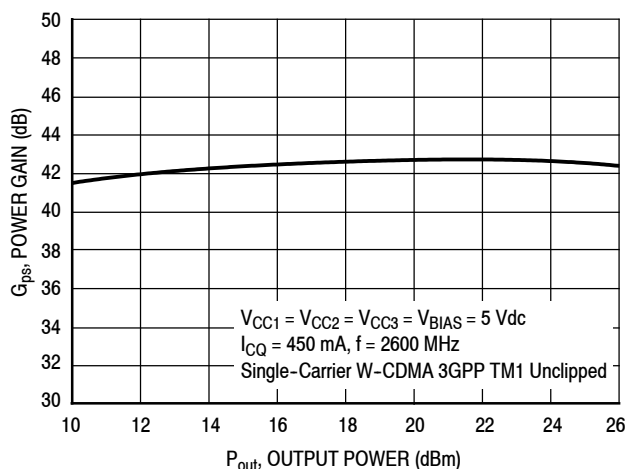

Figure 17. Power Gain versus Output Power

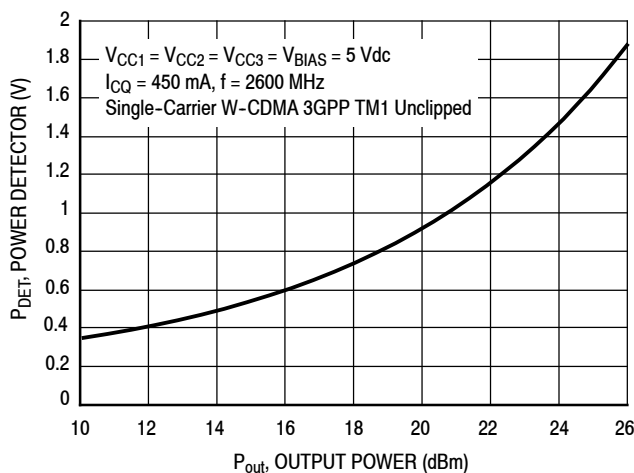
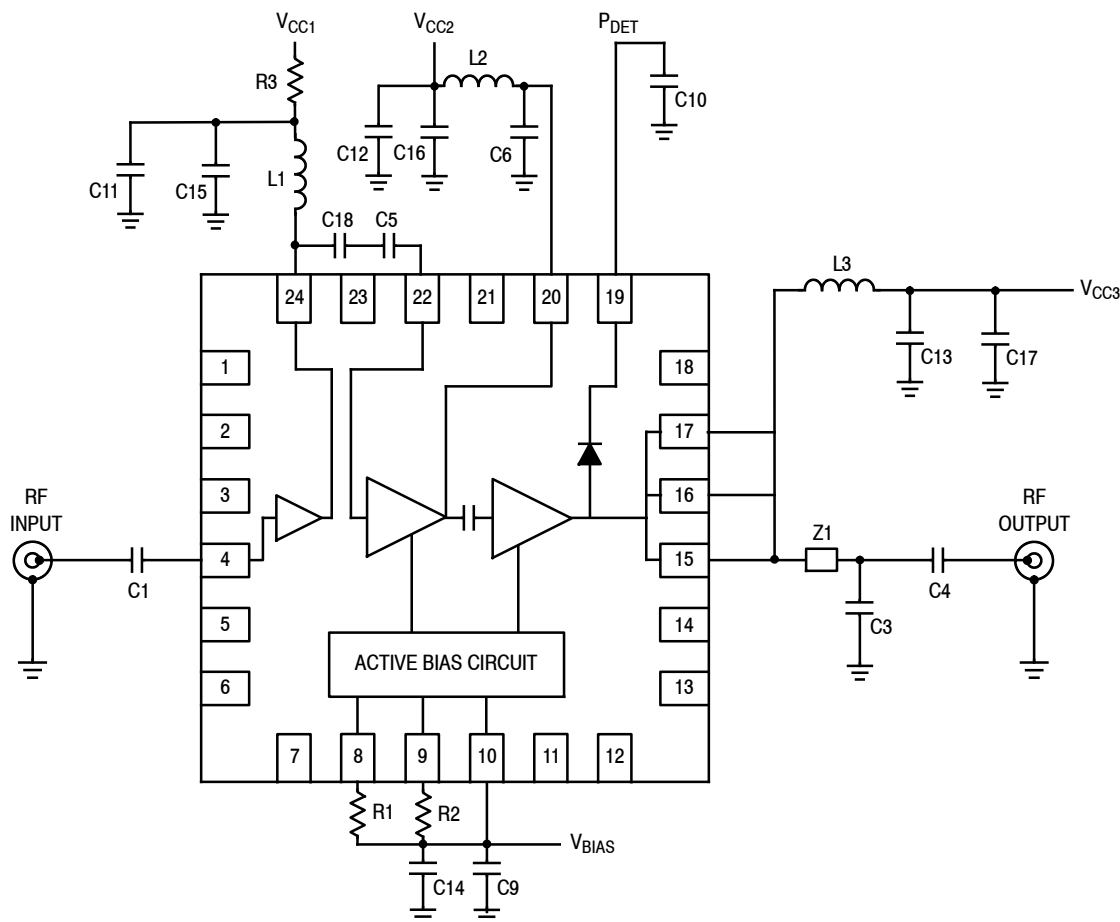

Figure 18. Power Detector versus Output Power

50 OHM APPLICATION CIRCUIT: 2110–2170 MHz, $I_{CQ} = 265$ mA



Note: Component number C7 is not used.

Z1 0.163" x 0.022" Microstrip

Figure 19. MMZ25333BT1 Test Circuit Schematic

Table 7. MMZ25333BT1 Test Circuit Component Designations and Values

Part	Description	Part Number	Manufacturer
C1, C4, C5	22 pF Chip Capacitors	04023J220BBS	AVX
C2	Component Not Placed		
C3	3.6 pF Chip Capacitor	04023J3R6BBS	AVX
C6	8.2 pF Chip Capacitor	04023J8R2BBS	AVX
C8	Component Not Placed		
C9, C11, C12, C13	1000 pF Chip Capacitors	GCM155R71E103KA37	Murata
C10	470 pF Chip Capacitor	GRM1555C1H471JA01	Murata
C14, C16	1 μ F Chip Capacitors	GRM188R61A105KE15	Murata
C15	0.01 μ F Chip Capacitor	C0603C103J5RAC	Kemet
C17	4.7 μ F Chip Capacitor	GRM188R60J475KE19	Murata
C18	2.2 pF Chip Capacitor	04023J12R2BBS	AVX
L1	56 nH Chip Inductor	0603HC-56NX	Coilcraft
L2	12 nH Chip Inductor	0603HC-12NX	Coilcraft
L3	6.8 nH Chip Inductor	0603HC-6N8X	Coilcraft
L4	Component Not Placed		
R1 ($I_{CQ} = 265$ mA)	1.8 k Ω , 1/16 W Chip Resistor	CR05-182J-B	Kyocera
R2 ($I_{CQ} = 265$ mA)	680 Ω , 1/16 W Chip Resistor	CR05-681J-B	Kyocera
R3	27 Ω , 1/10 W Chip Resistor	CR10-270J-T	Kyocera
PCB	Rogers RO4350B, 0.010", $\epsilon_r = 3.66$	M70506	MTL

Note: Component numbers C2, C8 and L4 are labeled on board but not placed.

MMZ25333BT1

50 OHM APPLICATION CIRCUIT: 2110–2170 MHz, $I_{CQ} = 265$ mA

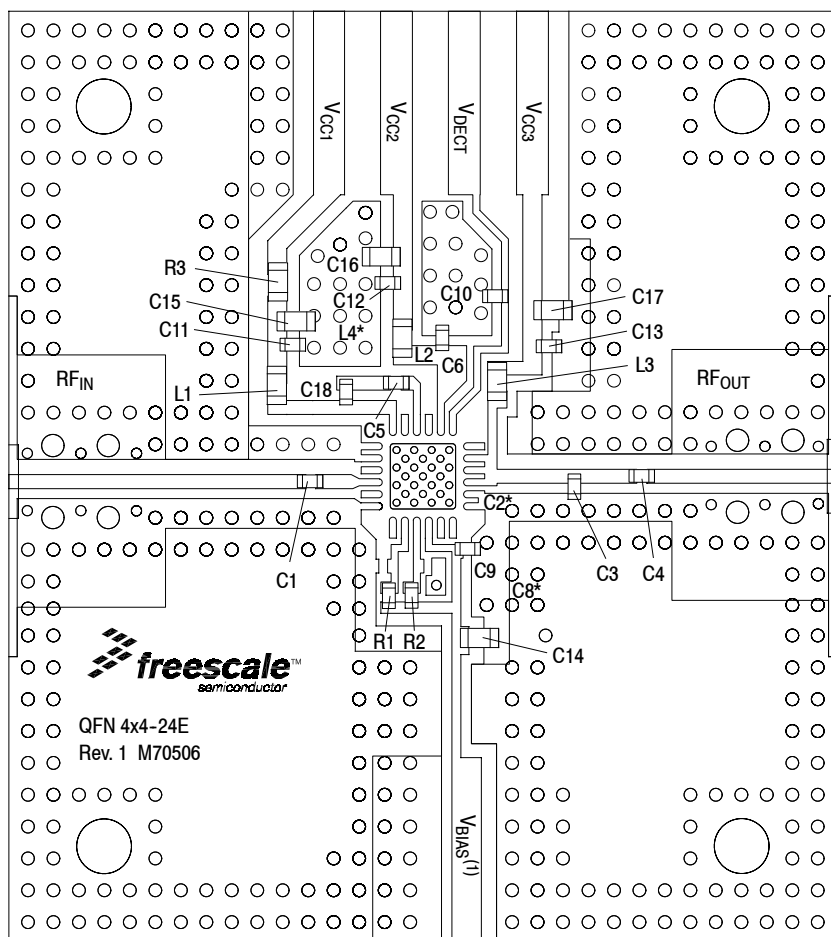

PCB actual size: 1.3" × 1.46".

(1) V_{BIAS} [Board] supplies V_{BA1} , V_{BA2} and V_{BIAS} [Device].

Note: Component number C7 is not used. Component numbers C2*, C8* and L4* are labeled on board but not placed.

Figure 20. MMZ25333BT1 Test Circuit Component Layout

Table 7. MMZ25333BT1 Test Circuit Component Designations and Values

Part	Description	Part Number	Manufacturer
C1, C4, C5	22 pF Chip Capacitors	04023J220BBS	AVX
C2	Component Not Placed		
C3	3.6 pF Chip Capacitor	04023J3R6BBS	AVX
C6	8.2 pF Chip Capacitor	04023J8R2BBS	AVX
C8	Component Not Placed		
C9, C11, C12, C13	1000 pF Chip Capacitors	GCM155R71E103KA37	Murata
C10	470 pF Chip Capacitor	GRM1555C1H471JA01	Murata
C14, C16	1 μ F Chip Capacitors	GRM188R61A105KE15	Murata
C15	0.01 μ F Chip Capacitor	C0603C103J5RAC	Kemet
C17	4.7 μ F Chip Capacitor	GRM188R60J475KE19	Murata
C18	2.2 pF Chip Capacitor	04023J12R2BBS	AVX
L1	56 nH Chip Inductor	0603HC-56NX	Coilcraft
L2	12 nH Chip Inductor	0603HC-12NX	Coilcraft
L3	6.8 nH Chip Inductor	0603HC-6N8X	Coilcraft
L4	Component Not Placed		
R1 ($I_{CQ} = 265$ mA)	1.8 k Ω , 1/16 W Chip Resistor	CR05-182J-B	Kyocera
R2 ($I_{CQ} = 265$ mA)	680 Ω , 1/16 W Chip Resistor	CR05-681J-B	Kyocera
R3	27 Ω , 1/10 W Chip Resistor	CR10-270J-T	Kyocera
PCB	Rogers RO4350B, 0.010", $\epsilon_r = 3.66$	M70506	MTL

(Test Circuit Component Designations and Values table repeated for reference.)

MMZ25333BT1

50 OHM TYPICAL CHARACTERISTICS: 2110–2170 MHz, $I_{CQ} = 265$ mA

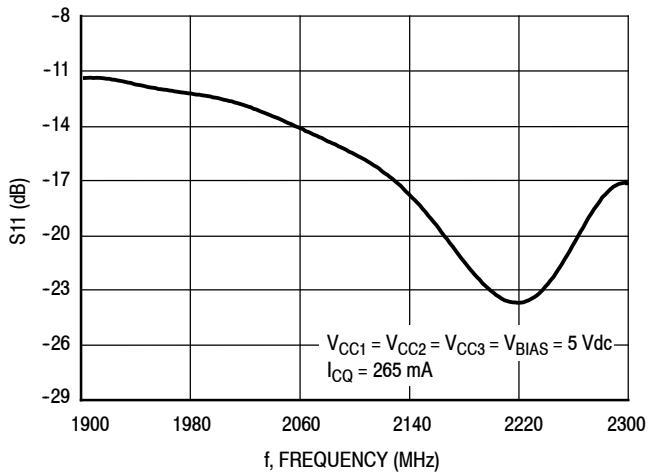

Figure 21. S11 versus Frequency

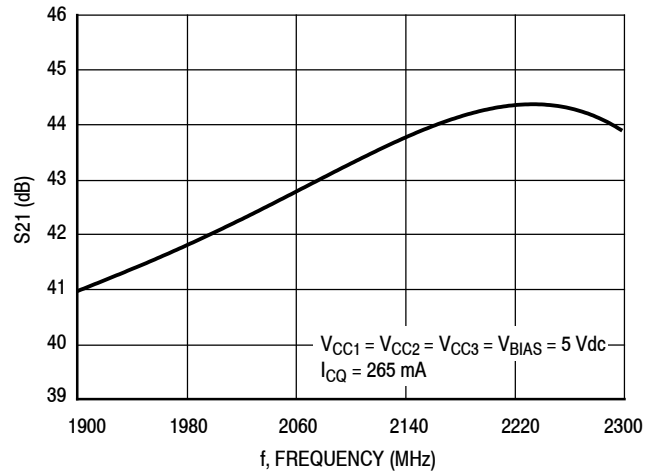

Figure 22. S21 versus Frequency

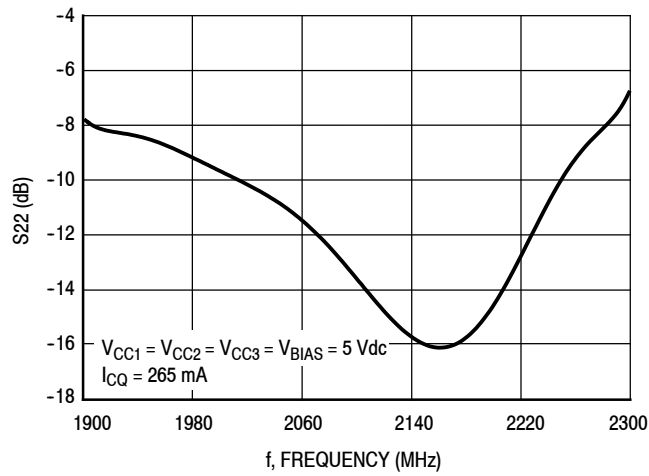

Figure 23. S22 versus Frequency

50 OHM TYPICAL CHARACTERISTICS: 2110–2170 MHz, $I_{CQ} = 265$ mA

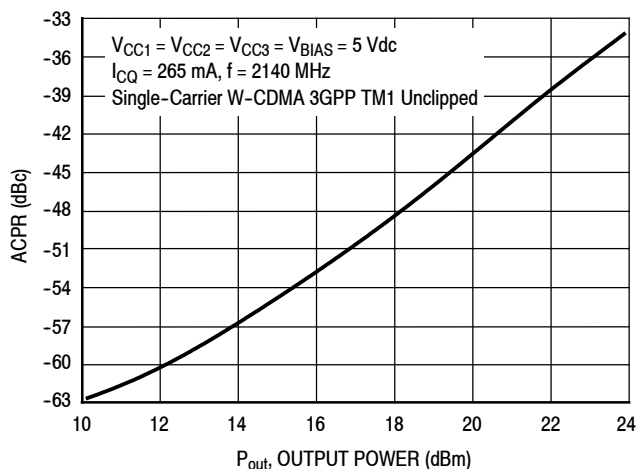

Figure 24. ACPR versus Output Power

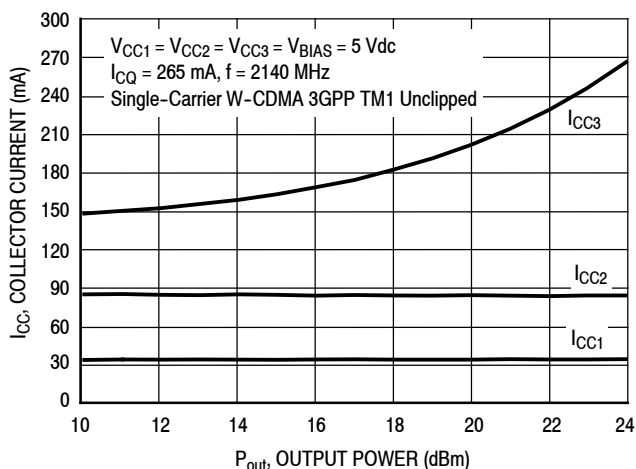

Figure 25. Stage Collector Current versus Output Power

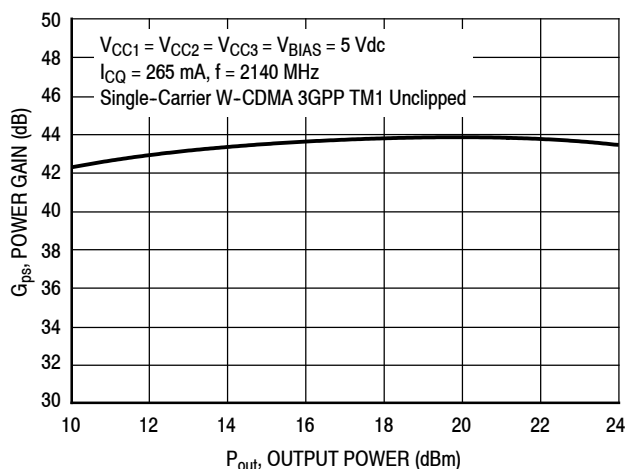

Figure 26. Power Gain versus Output Power

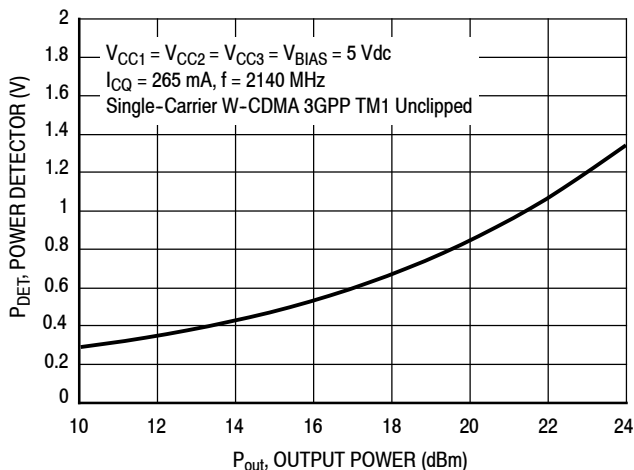

Figure 27. Power Detector versus Output Power

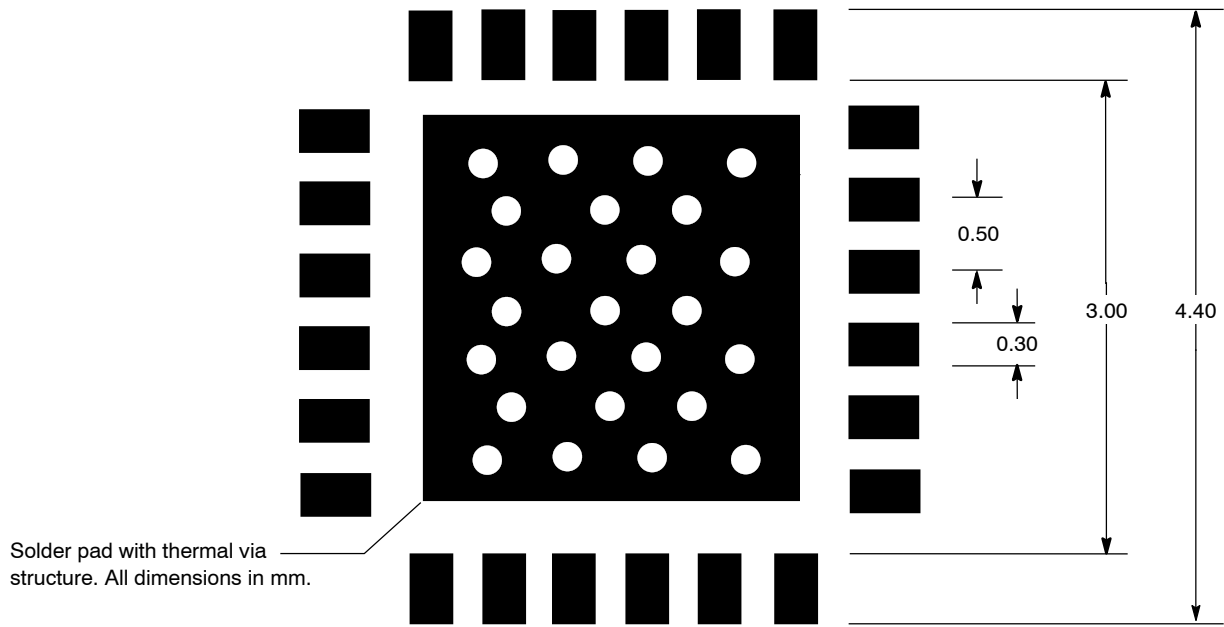
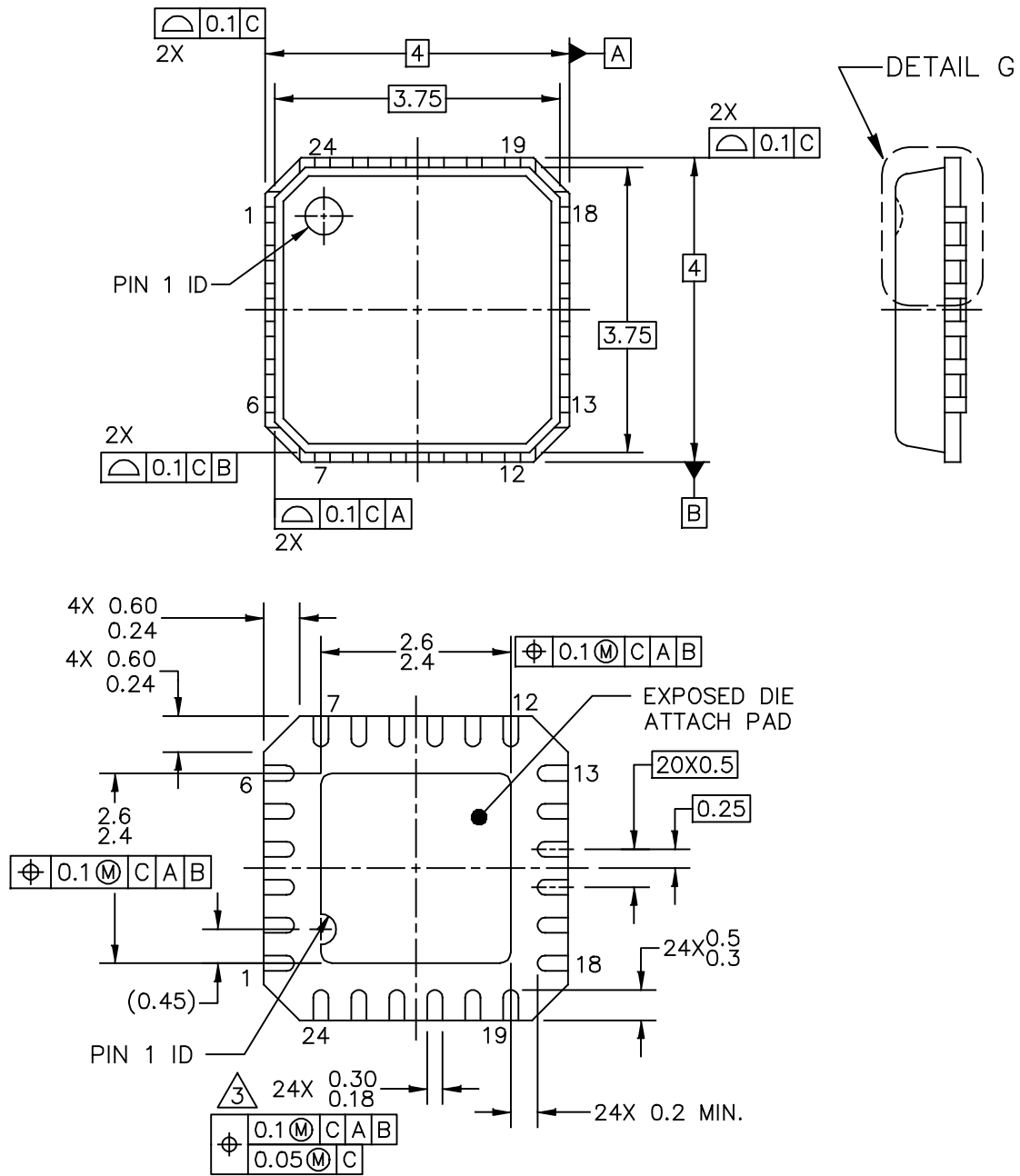

Figure 28. PCB Pad Layout for QFN 4 × 4



Figure 29. Product Marking

PACKAGE DIMENSIONS



© FREESCALE SEMICONDUCTOR, INC. ALL RIGHTS RESERVED.	MECHANICAL OUTLINE	PRINT VERSION NOT TO SCALE	
TITLE: QFN (PUNCH), THERMALLY ENHANCED 4 X 4 X 0.85, 0.5 PITCH, 24 TERMINAL	DOCUMENT NO: 98ASA00462D		REV: 0
	CASE NUMBER: 2285-01		29 MAR 2012
	STANDARD: NON-JEDEC		

MMZ25333BT1

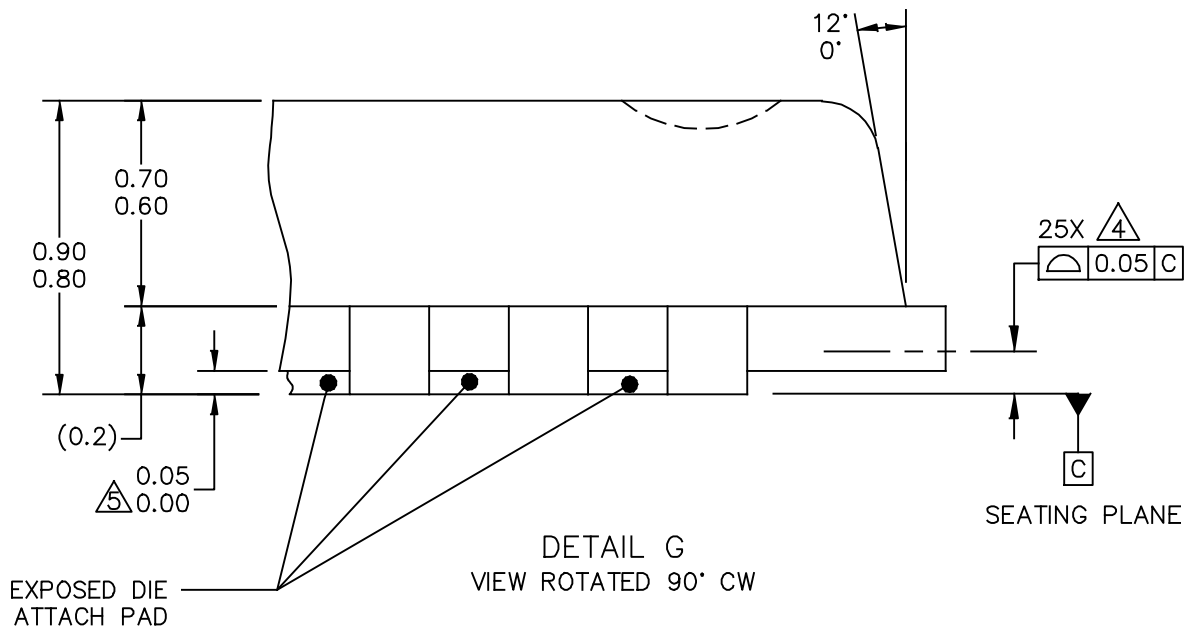

© FREESCALE SEMICONDUCTOR, INC. ALL RIGHTS RESERVED.	MECHANICAL OUTLINE	PRINT VERSION NOT TO SCALE	
TITLE: QFN (PUNCH), THERMALLY ENHANCED 4 X 4 X 0.85, 0.5 PITCH, 24 TERMINAL	DOCUMENT NO: 98ASA00462D	REV: 0	
	CASE NUMBER: 2285-01	29 MAR 2012	
	STANDARD: NON-JEDEC		

NOTES:

1. ALL DIMENSIONS ARE IN MILLIMETERS.

2. DIMENSIONING AND TOLERANCING PER ASME Y14.5M-1994.

3. THIS DIMENSION APPLIES TO METALIZED TERMINAL AND IS MEASURED BETWEEN 0.15 AND 0.30MM FROM TERMINAL TIP.

4. BILATERAL COPLANARITY ZONE APPLIES TO THE EXPOSED PAD AS WELL AS THE TERMINALS.

5. THIS DIMENSION APPLIES ONLY FOR TERMINALS.

© FREESCALE SEMICONDUCTOR, INC. ALL RIGHTS RESERVED.	MECHANICAL OUTLINE	PRINT VERSION NOT TO SCALE	
TITLE: QFN (PUNCH), THERMALLY ENHANCED 4 X 4 X 0.85, 0.5 PITCH, 24 TERMINAL	DOCUMENT NO: 98ASA00462D	REV: 0	
	CASE NUMBER: 2285-01	29 MAR 2012	
	STANDARD: NON-JEDEC		

PRODUCT DOCUMENTATION, SOFTWARE AND TOOLS

Refer to the following resources to aid your design process.

Application Notes

- AN1955: Thermal Measurement Methodology of RF Power Amplifiers

Software

- .s2p File

Development Tools

- Printed Circuit Boards

For Software and Tools, do a Part Number search at <http://www.freescale.com>, and select the "Part Number" link. Go to the Software & Tools tab on the part's Product Summary page to download the respective tool.

FAILURE ANALYSIS

At this time, because of the physical characteristics of the part, failure analysis is limited to electrical signature analysis. In cases where Freescale is contractually obligated to perform failure analysis (FA) services, full FA may be performed by third party vendors with moderate success. For updates contact your local Freescale Sales Office.

REVISION HISTORY

The following table summarizes revisions to this document.

Revision	Date	Description
0	June 2014	• Initial Release of Data Sheet
1	Aug. 2014	• Table 1, Maximum Ratings: updated Junction Temperature from 150°C to 175°C to reflect recent test results of the device, p. 2

How to Reach Us:

Home Page:
freescale.com

Web Support:
freescale.com/support

Information in this document is provided solely to enable system and software implementers to use Freescale products. There are no express or implied copyright licenses granted hereunder to design or fabricate any integrated circuits based on the information in this document.

Freescale reserves the right to make changes without further notice to any products herein. Freescale makes no warranty, representation, or guarantee regarding the suitability of its products for any particular purpose, nor does Freescale assume any liability arising out of the application or use of any product or circuit, and specifically disclaims any and all liability, including without limitation consequential or incidental damages. "Typical" parameters that may be provided in Freescale data sheets and/or specifications can and do vary in different applications, and actual performance may vary over time. All operating parameters, including "typicals," must be validated for each customer application by customer's technical experts. Freescale does not convey any license under its patent rights nor the rights of others. Freescale sells products pursuant to standard terms and conditions of sale, which can be found at the following address: freescale.com/SalesTermsandConditions.

Freescale and the Freescale logo are trademarks of Freescale Semiconductor, Inc., Reg. U.S. Pat. & Tm. Off. All other product or service names are the property of their respective owners.

© 2014 Freescale Semiconductor, Inc.

