



RF Power LDMOS Transistor

N-Channel Enhancement-Mode Lateral MOSFET

Designed for handheld two-way radio applications with frequencies from 136 to 941 MHz. The high gain, ruggedness and wideband performance of this device make it ideal for large-signal, common-source amplifier applications in handheld military radio equipment.

Narrowband Performance (7.5 Vdc, I_{DQ} = 100 mA, T_A = 25°C, CW)

| Frequency (MHz) | G _{ps} (dB) | η _D (%) | P _{out} (W) |
|--------------------|----------------------|--------------------|----------------------|
| 870 ⁽¹⁾ | 15.2 | 71.0 | 7.3 |

Wideband Performance (7.5 Vdc, T_A = 25°C, CW)

| Frequency (MHz) | P _{in} (W) | G _{ps} (dB) | η _D (%) | P _{out} (W) |
|--------------------------|---------------------|----------------------|--------------------|----------------------|
| 136–174 | 0.25 | 14.6 | 69.0 | 7.2 |
| 350–470 ^(2,5) | 0.20 | 15.6 | 60.9 | 7.3 |
| 450–520 ^(3,5) | 0.22 | 15.4 | 56.0 | 7.5 |
| 760–860 ^(4,5) | 0.23 | 15.1 | 48.1 | 7.5 |

Load Mismatch/Ruggedness

| Frequency (MHz) | Signal Type | VSWR | P _{in} (W) | Test Voltage | Result |
|--------------------|-------------|----------------------------|----------------------|--------------|-----------------------|
| 870 ⁽¹⁾ | CW | > 65:1 at all Phase Angles | 0.4 (3 dB Overdrive) | 10.8 | No Device Degradation |

1. Measured in 870 MHz narrowband test circuit.
2. Measured in 350–470 MHz UHF broadband reference circuit.
3. Measured in 450–520 MHz UHF broadband reference circuit.
4. Measured in 760–860 MHz UHF broadband reference circuit.
5. The values shown are the minimum measured performance numbers across the indicated frequency range.

Features

- Characterized for Operation from 136 to 941 MHz
- Unmatched Input and Output Allowing Wide Frequency Range Utilization
- Integrated ESD Protection
- Integrated Stability Enhancements
- Wideband — Full Power Across the Band
- Exceptional Thermal Performance
- Extreme Ruggedness
- High Linearity for: TETRA, SSB
- In Tape and Reel. T1 Suffix = 1,000 Units, 16 mm Tape Width, 7-inch Reel.

Typical Applications

- Output Stage VHF Band Handheld Radio
- Output Stage UHF Band Handheld Radio
- Output Stage for 700–800 MHz Handheld Radio

MMRF1021NT1

136–941 MHz, 7 W, 7.5 V
**WIDEBAND
 RF POWER LDMOS TRANSISTOR**

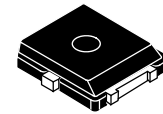

PLD-1.5W

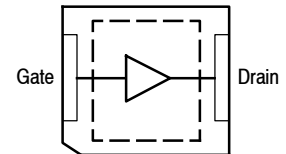

Note: The center pad on the backside of the package is the source terminal for the transistor.

Figure 1. Pin Connections

Table 1. Maximum Ratings

| Rating | Symbol | Value | Unit |
|--|-----------|-------------|-----------|
| Drain-Source Voltage | V_{DSS} | -0.5, +30 | Vdc |
| Gate-Source Voltage | V_{GS} | -6.0, +12 | Vdc |
| Operating Voltage | V_{DD} | 12.5, +0 | Vdc |
| Storage Temperature Range | T_{stg} | -65 to +150 | °C |
| Case Operating Temperature Range | T_C | -40 to +150 | °C |
| Operating Junction Temperature (1,2) | T_J | -40 to +150 | °C |
| Total Device Dissipation @ $T_C = 25^\circ\text{C}$ Derate above 25°C | P_D | 114 0.91 | W W/°C |

Table 2. Thermal Characteristics

| Characteristic | Symbol | Value (2,3) | Unit |
|--|-----------------|-------------|------|
| Thermal Resistance, Junction to Case Case Temperature 74°C, 7 W CW, 7.5 Vdc, $I_{DQ} = 100$ mA, 870 MHz | $R_{\theta JC}$ | 1.1 | °C/W |

Table 3. ESD Protection Characteristics

| Test Methodology | Class |
|---------------------------------------|-------------------|
| Human Body Model (per JESD22-A114) | 2, passes 2500 V |
| Machine Model (per EIA/JESD22-A115) | B, passes 200 V |
| Charge Device Model (per JESD22-C101) | IV, passes 2000 V |

Table 4. Moisture Sensitivity Level

| Test Methodology | Rating | Package Peak Temperature | Unit |
|--------------------------------------|--------|--------------------------|------|
| Per JESD22-A113, IPC/JEDEC J-STD-020 | 3 | 260 | °C |

Table 5. Electrical Characteristics ($T_A = 25^\circ\text{C}$ unless otherwise noted)

| Characteristic | Symbol | Min | Typ | Max | Unit |
|----------------|--------|-----|-----|-----|------|
|----------------|--------|-----|-----|-----|------|

Off Characteristics

| | | | | | |
|--|-----------|---|---|----|-----------------|
| Zero Gate Voltage Drain Leakage Current ($V_{DS} = 30$ Vdc, $V_{GS} = 0$ Vdc) | I_{DSS} | — | — | 10 | μAdc |
| Zero Gate Voltage Drain Leakage Current ($V_{DS} = 7.5$ Vdc, $V_{GS} = 0$ Vdc) | I_{DSS} | — | — | 2 | μAdc |
| Gate-Source Leakage Current ($V_{GS} = 5$ Vdc, $V_{DS} = 0$ Vdc) | I_{GSS} | — | — | 1 | μAdc |

On Characteristics

| | | | | | |
|--|--------------|-----|------|-----|-----|
| Gate Threshold Voltage ($V_{DS} = 10$ Vdc, $I_D = 110$ μAdc) | $V_{GS(th)}$ | 1.6 | 2.1 | 2.6 | Vdc |
| Drain-Source On-Voltage ($V_{GS} = 10$ Vdc, $I_D = 1.1$ Adc) | $V_{DS(on)}$ | — | 0.12 | — | Vdc |
| Forward Transconductance ($V_{DS} = 7.5$ Vdc, $I_D = 3$ Adc) | g_{fs} | — | 9.8 | — | S |

Dynamic Characteristics

| | | | | | |
|--|-----------|---|-----|---|----|
| Reverse Transfer Capacitance ($V_{DS} = 7.5$ Vdc \pm 30 mV(rms)ac @ 1 MHz, $V_{GS} = 0$ Vdc) | C_{rss} | — | 2.7 | — | pF |
| Output Capacitance ($V_{DS} = 7.5$ Vdc \pm 30 mV(rms)ac @ 1 MHz, $V_{GS} = 0$ Vdc) | C_{oss} | — | 56 | — | pF |
| Input Capacitance ($V_{DS} = 7.5$ Vdc, $V_{GS} = 0$ Vdc \pm 30 mV(rms)ac @ 1 MHz) | C_{iss} | — | 107 | — | pF |

1. Continuous use at maximum temperature will affect MTTF.
2. MTTF calculator available at <http://www.freescale.com/rf>. Select Software & Tools/Development Tools/Calculators to access MTTF calculators by product.
3. Refer to AN1955, *Thermal Measurement Methodology of RF Power Amplifiers*. Go to <http://www.freescale.com/rf>. Select Documentation/Application Notes - AN1955.

(continued)

Table 5. Electrical Characteristics ($T_A = 25^\circ\text{C}$ unless otherwise noted) **(continued)**

| Characteristic | Symbol | Min | Typ | Max | Unit |
|----------------|--------|-----|-----|-----|------|
|----------------|--------|-----|-----|-----|------|

Functional Tests (In Freescale Test Fixture, 50 ohm system) $V_{DD} = 7.5\text{ Vdc}$, $I_{DQ} = 100\text{ mA}$, $P_{in} = 0.22\text{ W}$, $f = 870\text{ MHz}$

| | | | | | |
|--------------------------------------|-----------|---|------|---|---|
| Common-Source Amplifier Output Power | P_{out} | — | 7.3 | — | W |
| Drain Efficiency | η_D | — | 71.0 | — | % |

Load Mismatch/Ruggedness (In Freescale Test Fixture, 50 ohm system) $I_{DQ} = 100\text{ mA}$

| Frequency (MHz) | Signal Type | VSWR | P_{in} (W) | Test Voltage, V_{DD} | Result |
|-----------------|-------------|----------------------------|-------------------------|------------------------|-----------------------|
| 870 | CW | > 65:1 at all Phase Angles | 0.4 (3 dB Overdrive) | 10.8 | No Device Degradation |

TYPICAL CHARACTERISTICS

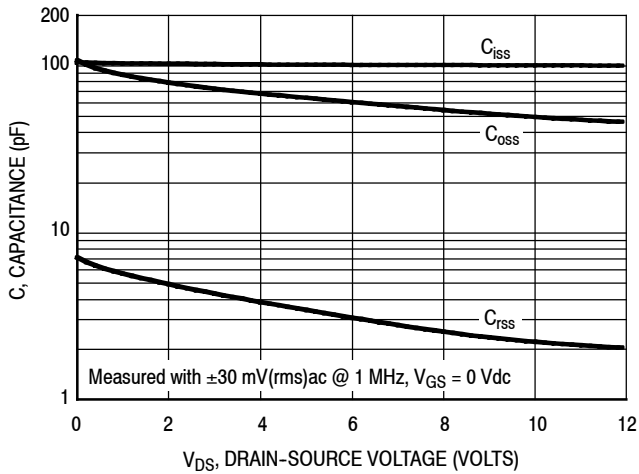

Figure 2. Capacitance versus Drain-Source Voltage

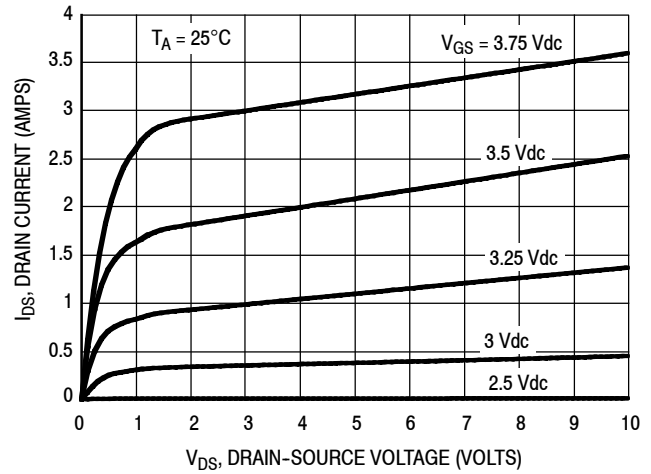
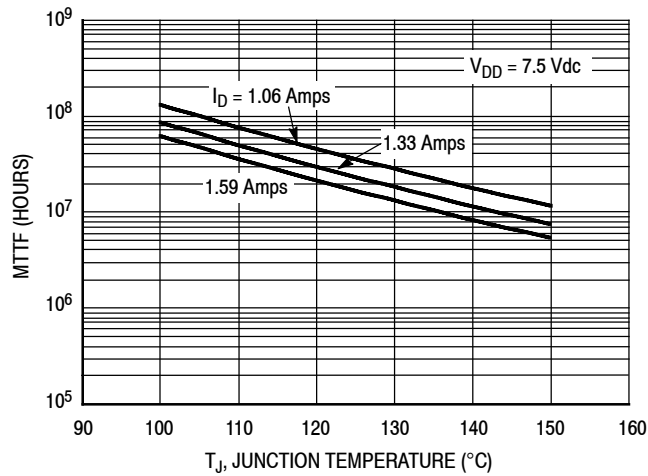

Figure 3. Drain Current versus Drain-Source Voltage



Note: MTTF value represents the total cumulative operating time under indicated test conditions.

MTTF calculator available at <http://www.freescale.com/rf>. Select Software & Tools/Development Tools/Calculators to access MTTF calculators by product.

Figure 4. MTTF versus Junction Temperature — CW

870 MHz NARROWBAND PRODUCTION TEST FIXTURE

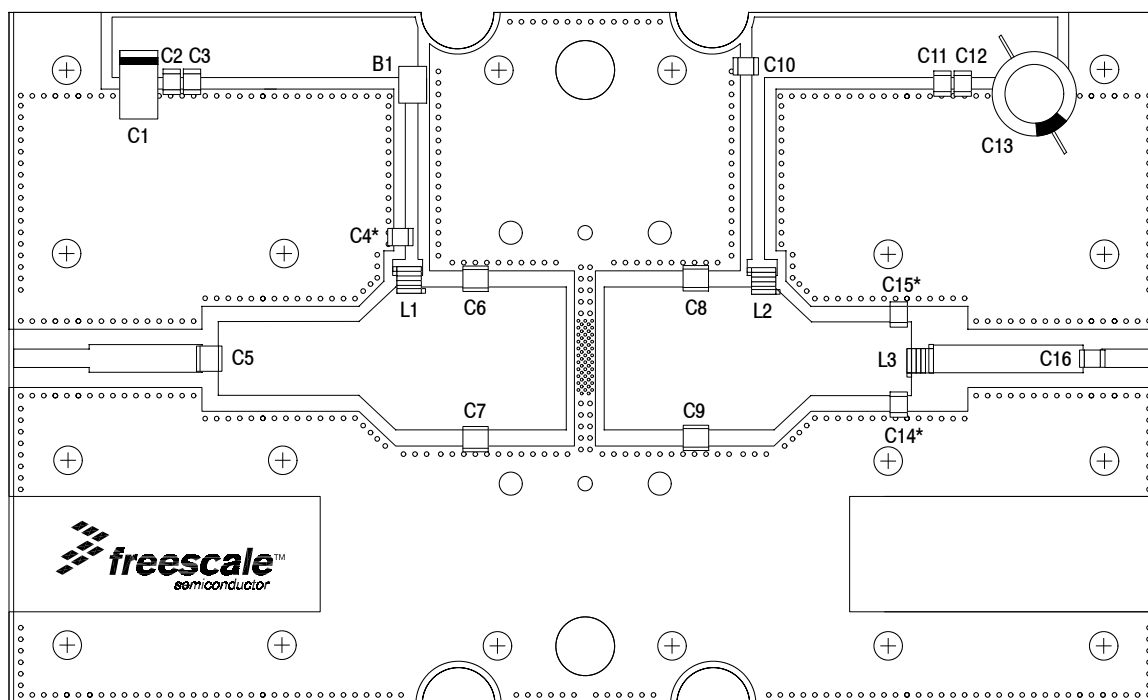

*C4, C14 and C15 are mounted vertically.

Figure 5. MMRF1021NT1 Narrowband Test Circuit Component Layout — 870 MHz

Table 6. MMRF1021NT1 Narrowband Test Circuit Component Designations and Values — 870 MHz

| Part | Description | Part Number | Manufacturer |
|--------------|---|----------------------|--------------|
| B1 | RF Bead, Short | 2743019447 | Fair-Rite |
| C1 | 22 μ F, 35 V Tantalum Capacitor | T491X226K035AT | Kemet |
| C2, C12 | 0.1 μ F Chip Capacitors | CDR33BX104AKWS | Kemet |
| C3, C11 | 0.01 μ F Chip Capacitors | C0805C103K5RAC | Kemet |
| C4, C10, C16 | 56 pF Chip Capacitors | ATC100B560CT500XT | ATC |
| C5 | 3.9 pF Chip Capacitor | ATC100B3R9CT500XT | ATC |
| C6, C7 | 7.5 pF Chip Capacitors | ATC100B7R5CT500XT | ATC |
| C8, C9 | 6.8 pF Chip Capacitors | ATC100B6R8CT500XT | ATC |
| C13 | 330 μ F, 35 V Electrolytic Capacitor | MCGPR35V337M10X16-RH | Multicomp |
| C14, C15 | 3.6 pF Chip Capacitors | ATC100B3R6CT500XT | ATC |
| L1 | 8.0 nH Inductor | A03TKLC | Coilcraft |
| L2 | 18.5 nH Inductor | A05TKLC | Coilcraft |
| L3 | 5.0 nH Inductor | A02TKLC | Coilcraft |
| PCB | Rogers RO4350B, 0.030", $\epsilon_r = 3.66$ | — | MTL |

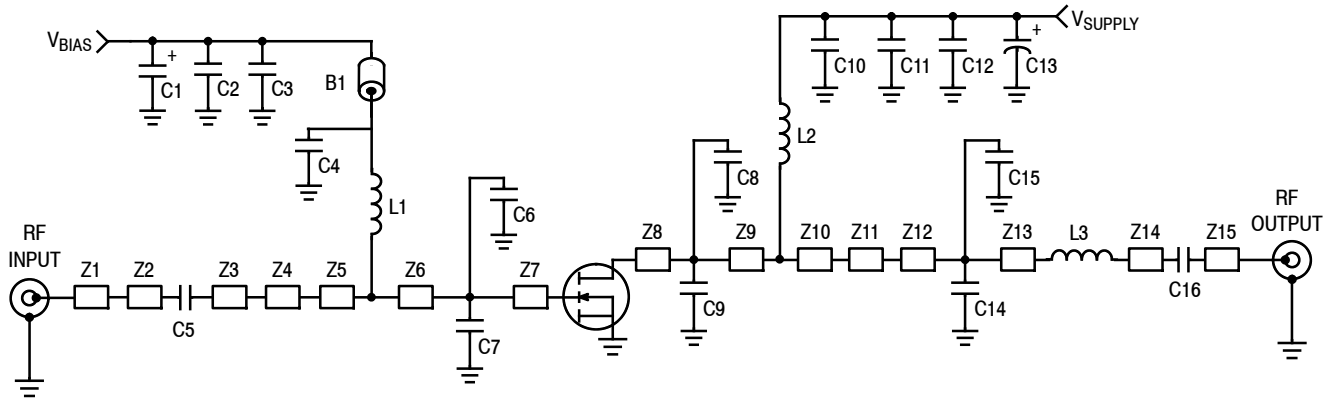

Figure 6. MMRF1021NT1 Narrowband Test Circuit Schematic — 870 MHz

Table 7. MMRF1021NT1 Narrowband Test Circuit Microstrips — 870 MHz

| Microstrip | Description |
|------------|--------------------------------|
| Z1 | 0.328" × 0.080" Microstrip |
| Z2 | 0.490" × 0.120" Microstrip |
| Z3 | 0.610" × 0.320" Microstrip |
| Z4 | 0.160" × 0.320" × 0.620" Taper |
| Z5 | 0.058" × 0.620" Microstrip |
| Z6 | 0.288" × 0.620" Microstrip |
| Z7 | 0.394" × 0.620" Microstrip |
| Z8 | 0.398" × 0.620" Microstrip |

| Microstrip | Description |
|------------|--------------------------------|
| Z9 | 0.295" × 0.620" Microstrip |
| Z10 | 0.046" × 0.620" Microstrip |
| Z11 | 0.159" × 0.620" × 0.320" Taper |
| Z12 | 0.379" × 0.320" Microstrip |
| Z13 | 0.055" × 0.320" Microstrip |
| Z14 | 0.665" × 0.120" Microstrip |
| Z15 | 0.238" × 0.080" Microstrip |

TYPICAL CHARACTERISTICS — 870 MHz

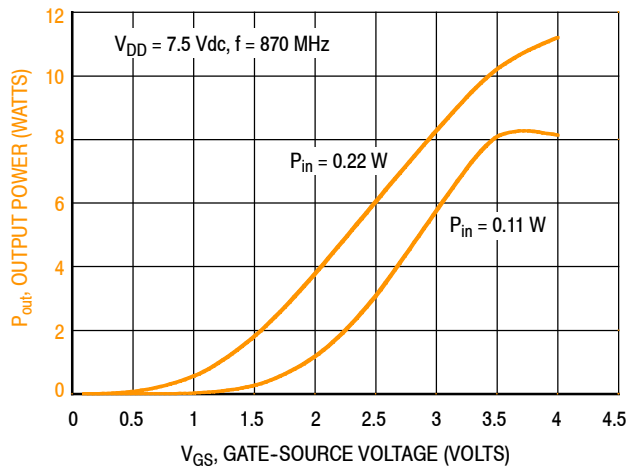

Figure 7. Output Power versus Gate-Source Voltage at a Constant Input Power

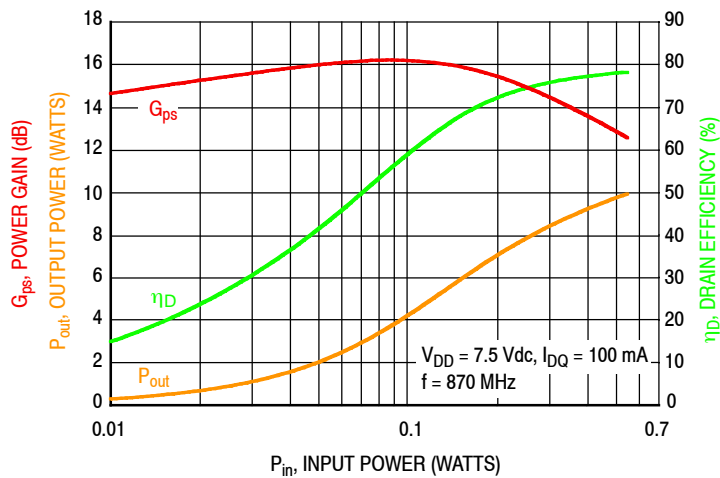

Figure 8. Power Gain, Output Power and Drain Efficiency versus Input Power

$V_{DD} = 7.5$ Vdc, $I_{DQ} = 100$ mA, $P_{out} = 7$ W

| f MHz | Z_{source} Ω | Z_{load} Ω |
|----------|--------------------------|------------------------|
| 870 | $0.54 + j1.35$ | $1.31 + j1.93$ |

Z_{source} = Test circuit impedance as measured from gate to ground.

Z_{load} = Test circuit impedance as measured from drain to ground.

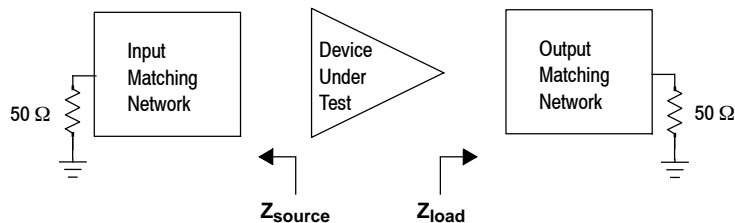

Figure 9. Narrowband Series Equivalent Source and Load Impedance — 870 MHz

350–470 MHz UHF BROADBAND REFERENCE CIRCUIT

Table 8. 350–470 MHz UHF Broadband Performance (In Freescale Reference Circuit, 50 ohm system)

$V_{DD} = 7.5$ Vdc, $I_{DQ} = 200$ mA, $T_A = 25^\circ\text{C}$, CW

| Frequency (MHz) | P_{in} (W) | G_{ps} (dB) | η_D (%) | P_{out} (W) |
|-----------------|--------------|---------------|--------------|---------------|
| 350 | 0.15 | 16.6 | 60.9 | 7.3 |
| 410 | 0.15 | 16.6 | 66.5 | 7.3 |
| 470 | 0.20 | 15.6 | 70.1 | 7.3 |

Table 9. Load Mismatch/Ruggedness (In Freescale Reference Circuit)

| Frequency (MHz) | Signal Type | VSWR | P_{in} (W) | Test Voltage, V_{DD} | Result |
|-----------------|-------------|----------------------------|-------------------------|------------------------|-----------------------|
| 470 | CW | > 65:1 at all Phase Angles | 0.4 (3 dB Overdrive) | 10.8 | No Device Degradation |

350–470 MHz UHF BROADBAND REFERENCE CIRCUIT

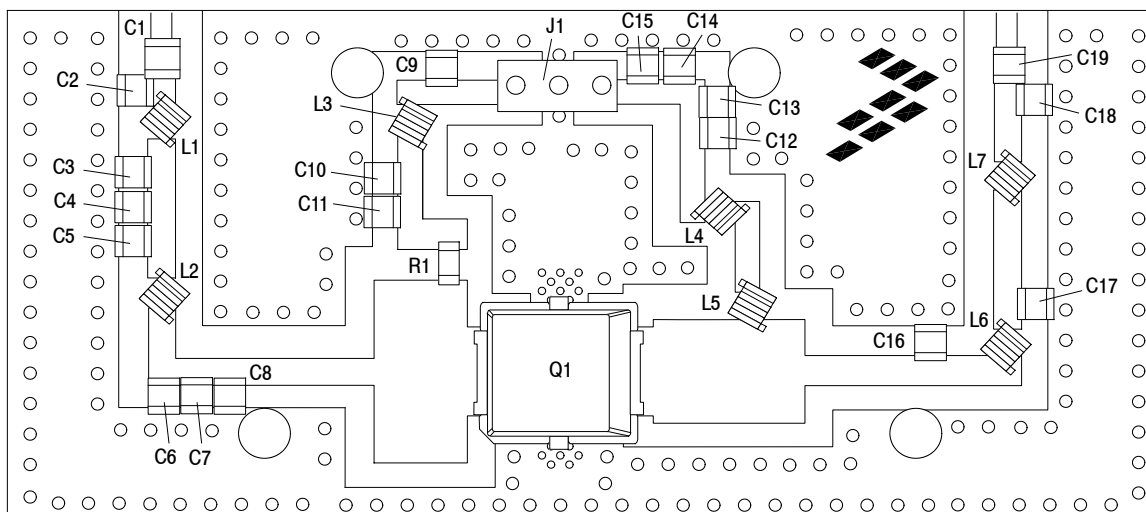

Figure 10. MMRF1021NT1 UHF Broadband Reference Circuit Component Layout — 350–470 MHz

Table 10. MMRF1021NT1 UHF Broadband Reference Circuit Component Designations and Values — 350–470 MHz

| Part | Description | Part Number | Manufacturer |
|--------------|---|---------------------|--------------|
| C1, C10, C19 | 100 pF Chip Capacitors | ATC600F101JT250XT | ATC |
| C2 | 10 pF Chip Capacitor | ATC600F100JT250XT | ATC |
| C3 | 3.0 pF Chip Capacitor | ATC600F3R0BT250XT | ATC |
| C4, C8 | 27 pF Chip Capacitors | ATC600F270JT250XT | ATC |
| C5 | 5.1 pF Chip Capacitor | ATC600F5R1BT250XT | ATC |
| C6, C7 | 30 pF Chip Capacitors | ATC600F300JT250XT | ATC |
| C9 | 10 nF Chip Capacitor | C1210C103J5GAC-TU | Kemet |
| C11 | 82 pF Chip Capacitor | ATC600F820JT250XT | ATC |
| C12 | 240 pF Chip Capacitor | ATC600F241JT250XT | ATC |
| C13 | 2.2 μ F Chip Capacitor | C3225X7R1H225K250AB | TDK |
| C14 | 0.1 μ F Chip Capacitor | GRM21BR71H104KA01B | Murata |
| C15 | 0.01 μ F Chip Capacitor | GRM21BR72A103KA01B | Murata |
| C16 | 47 pF Chip Capacitor | ATC600F470JT250XT | ATC |
| C17 | 18 pF Chip Capacitor | ATC600F180BT250XT | ATC |
| C18 | 7.5 pF Chip Capacitor | ATC100A7R5JT150XT | ATC |
| J1 | 3-pin Header | 22-28-8360 | Molex |
| L1 | 8.1 nH Inductor | 0908SQ8N1 | Coilcraft |
| L2 | 2.55 nH, 3 Turn Inductor | 0906-3JLC | Coilcraft |
| L3, L4, L5 | 21.5 nH Inductors | 0908SQ22N | Coilcraft |
| L6 | 3.85 nH, 4 Turn Inductor | 0906-4JLC | Coilcraft |
| L7 | 8.9 nH Inductor | 0806SQ8N9 | Coilcraft |
| Q1 | RF Power LDMOS Transistor | MMRF1021NT1 | Freescale |
| R1 | 62 Ω , 1/10 W Chip Resistor | RG2012N-620-B-T1 | Susumu |
| PCB | Shengyi S1000-2, 0.020", $\epsilon_r = 4.8$ | — | MTL |

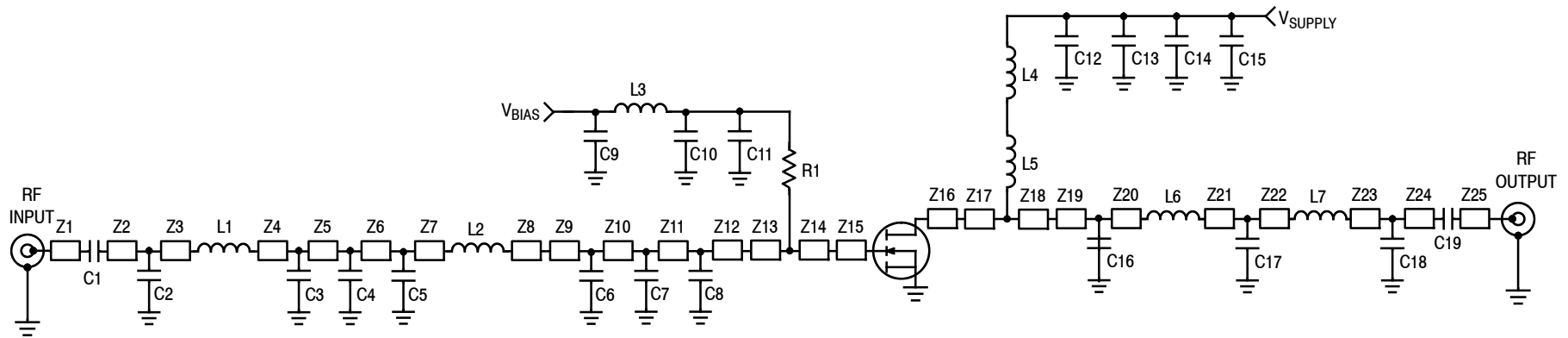

Figure 11. MMRF1021NT1 UHF Broadband Reference Circuit Schematic — 350–470 MHz

Table 11. MMRF1021NT1 UHF Broadband Reference Circuit Microstrips — 350–470 MHz

| Microstrip | Description | Microstrip | Description | Microstrip | Description |
|------------|----------------------------|------------|----------------------------|------------|----------------------------|
| Z1 | 0.060" × 0.034" Microstrip | Z10 | 0.037" × 0.046" Microstrip | Z18 | 0.088" × 0.170" Microstrip |
| Z2 | 0.026" × 0.046" Microstrip | Z11 | 0.055" × 0.046" Microstrip | Z19 | 0.205" × 0.046" Microstrip |
| Z3 | 0.026" × 0.046" Microstrip | Z12 | 0.235" × 0.046" Microstrip | Z20 | 0.148" × 0.046" Microstrip |
| Z4 | 0.060" × 0.046" Microstrip | Z13 | 0.121" × 0.300" Microstrip | Z21 | 0.032" × 0.046" Microstrip |
| Z5 | 0.054" × 0.046" Microstrip | Z14 | 0.031" × 0.300" Microstrip | Z22 | 0.195" × 0.046" Microstrip |
| Z6 | 0.054" × 0.046" Microstrip | Z15 | 0.070" × 0.146" Microstrip | Z23 | 0.089" × 0.046" Microstrip |
| Z7 | 0.060" × 0.046" Microstrip | Z16 | 0.070" × 0.146" Microstrip | Z24 | 0.046" × 0.046" Microstrip |
| Z8 | 0.084" × 0.046" Microstrip | Z17 | 0.160" × 0.170" Microstrip | Z25 | 0.060" × 0.034" Microstrip |
| Z9 | 0.044" × 0.046" Microstrip | | | | |

TYPICAL CHARACTERISTICS — 350–470 MHz UHF BROADBAND REFERENCE CIRCUIT

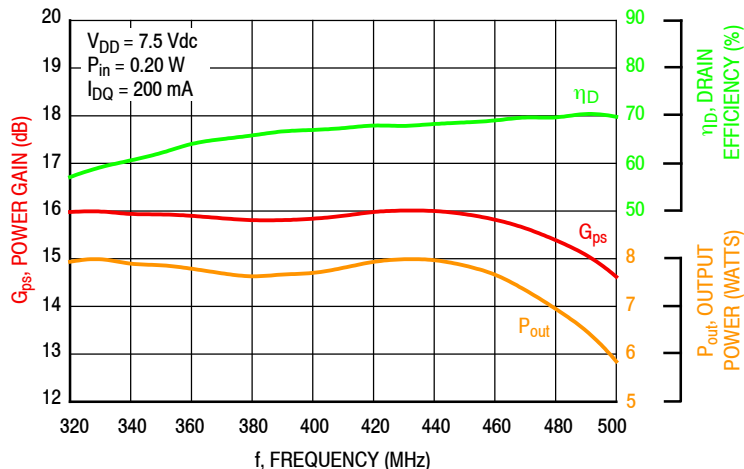

Figure 12. Power Gain, Drain Efficiency and Output Power versus Frequency at a Constant Input Power

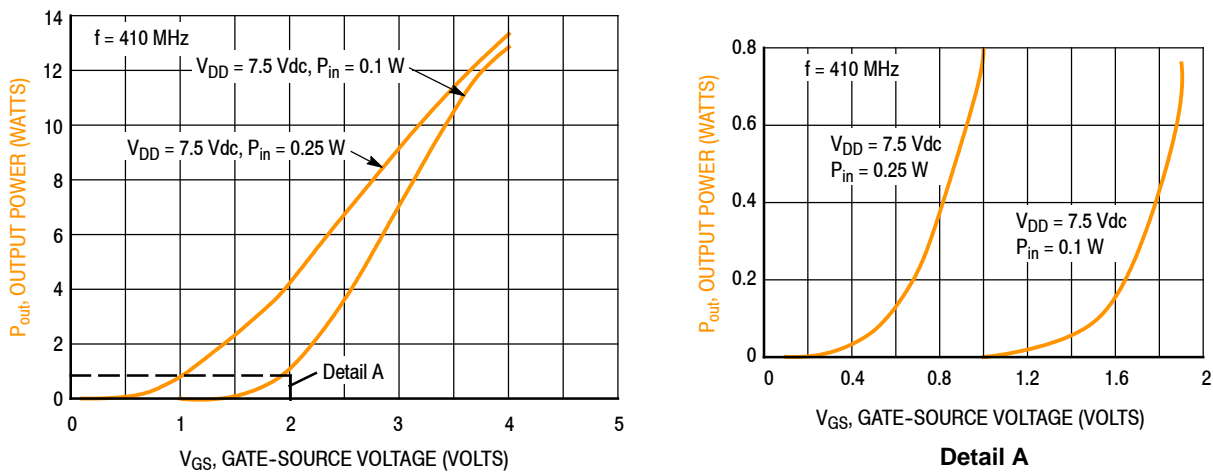

Figure 13. Output Power versus Gate-Source Voltage

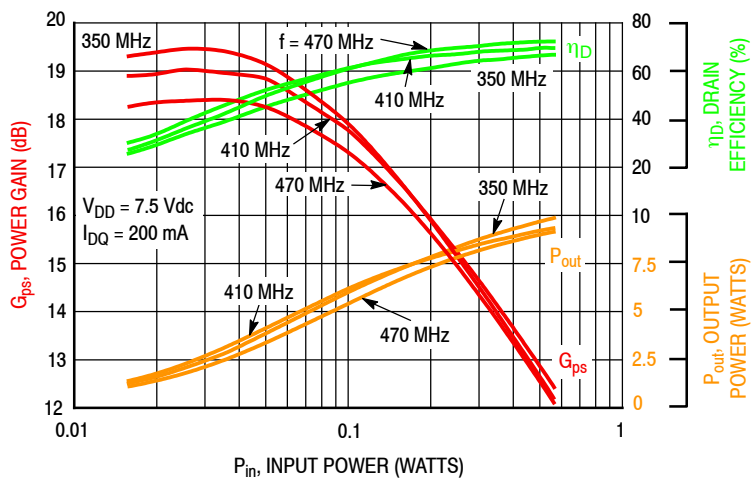
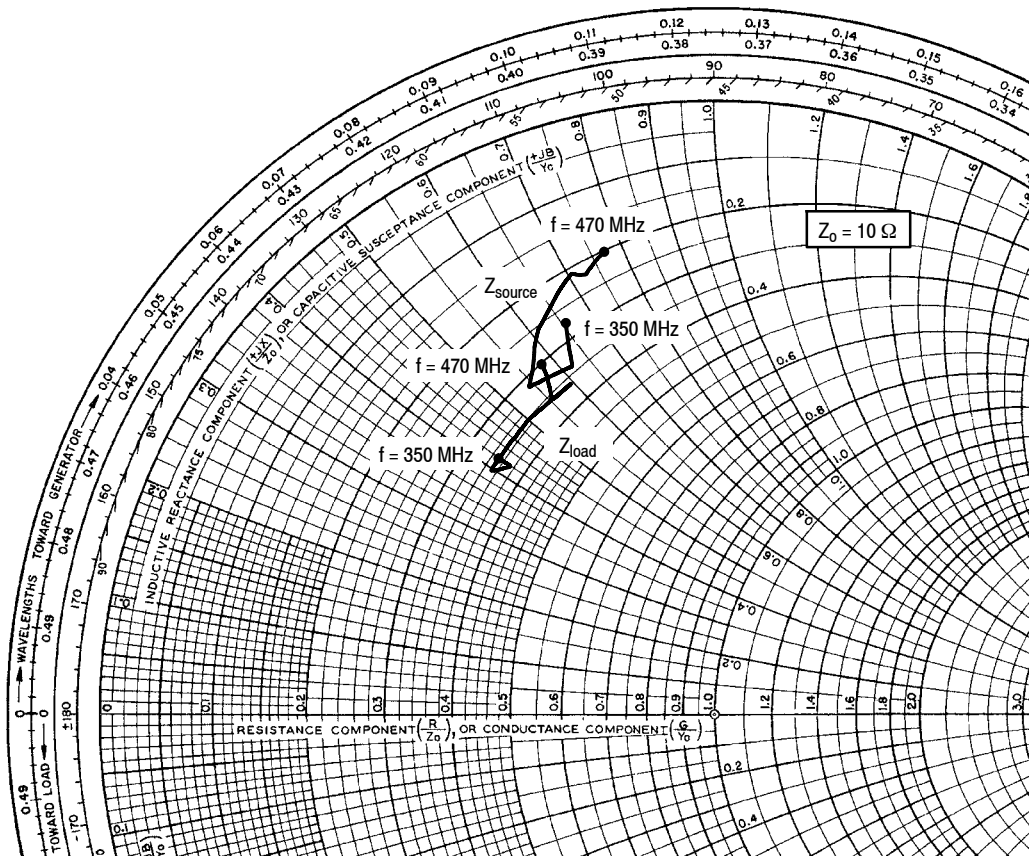

Figure 14. Power Gain, Drain Efficiency and Output Power versus Input Power and Frequency

350–470 MHz UHF BROADBAND REFERENCE CIRCUIT



$V_{DD} = 7.5 \text{ Vdc}$, $I_{DQ} = 200 \text{ mA}$, $P_{out} = 7.5 \text{ W}$

| f MHz | Z_{source} Ω | Z_{load} Ω |
|----------|--------------------------|------------------------|
| 350 | $2.7 + j6.6$ | $3.5 + j4.2$ |
| 370 | $3.3 + j6.2$ | $3.7 + j4.2$ |
| 390 | $3.1 + j5.4$ | $3.5 + j4.0$ |
| 410 | $2.6 + j6.1$ | $3.5 + j5.0$ |
| 430 | $2.1 + j7.1$ | $3.6 + j5.9$ |
| 450 | $2.2 + j7.3$ | $3.6 + j5.6$ |
| 470 | $2.0 + j7.7$ | $3.0 + j5.8$ |

Z_{source} = Test circuit impedance as measured from gate to ground.

Z_{load} = Test circuit impedance as measured from drain to ground.

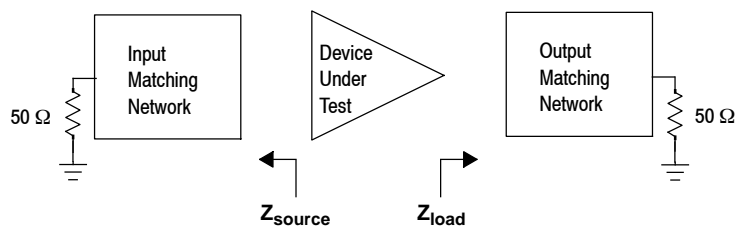

Figure 15. UHF Broadband Series Equivalent Source and Load Impedance — 350–470 MHz

450–520 MHz UHF BROADBAND REFERENCE CIRCUIT

Table 12. 450–520 MHz UHF Broadband Performance (In Freescale Reference Circuit, 50 ohm system)
 $V_{DD} = 7.5 \text{ Vdc}$, $I_{DQ} = 150 \text{ mA}$, $T_A = 25^\circ\text{C}$, CW

| Frequency (MHz) | P_{in} (W) | G_{ps} (dB) | η_D (%) | P_{out} (W) |
|-----------------|--------------|---------------|--------------|---------------|
| 450 | 0.21 | 15.4 | 57.7 | 7.5 |
| 485 | 0.21 | 15.5 | 56.0 | 7.5 |
| 520 | 0.18 | 16.2 | 66.3 | 7.5 |

Table 13. Load Mismatch/Ruggedness (In Freescale Reference Circuit)

| Frequency (MHz) | Signal Type | VSWR | P_{in} (W) | Test Voltage, V_{DD} | Result |
|-----------------|-------------|----------------------------|-------------------------|------------------------|-----------------------|
| 520 | CW | > 65:1 at all Phase Angles | 0.2 (3 dB Overdrive) | 10.8 | No Device Degradation |

450–520 MHz UHF BROADBAND REFERENCE CIRCUIT

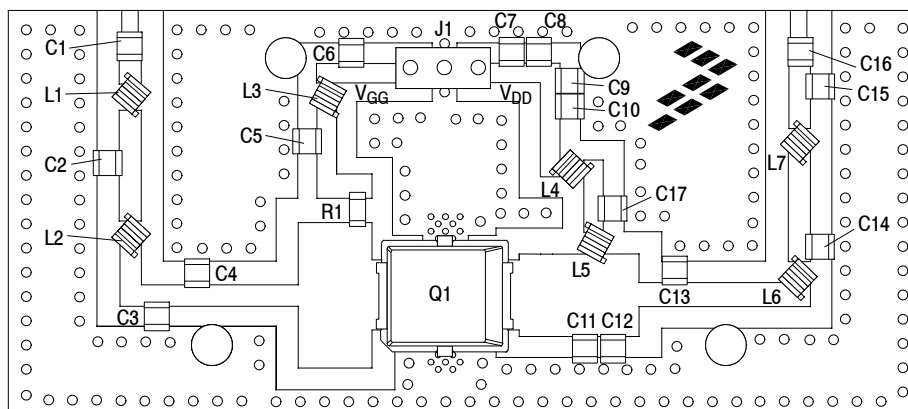

Figure 16. MMRF1021NT1 UHF Broadband Reference Circuit Component Layout — 450–520 MHz

Table 14. MMRF1021NT1 UHF Broadband Reference Circuit Component Designations and Values — 450–520 MHz

| Part | Description | Part Number | Manufacturer |
|---------|---|--------------------|--------------|
| C1, C16 | 100 pF Chip Capacitors | ATC600F101JT250XT | ATC |
| C2 | 7.5 pF Chip Capacitor | GQM2195C2E7R5BB12D | Murata |
| C3 | 5.6 pF Chip Capacitor | ATC600F5R6BT250XT | ATC |
| C4 | 39 pF Chip Capacitor | ATC600F390JT250XT | ATC |
| C5, C9 | 240 pF Chip Capacitors | ATC600F241JT250XT | ATC |
| C6, C7 | 0.1 μ F Chip Capacitors | GRM21BR71H104KA01B | Murata |
| C8 | 0.01 μ F Chip Capacitor | GRM21BR72A103KA01B | Murata |
| C10 | 2.2 μ F Chip Capacitor | GRM31CR71H225KA88L | Murata |
| C11, 12 | 12 pF Chip Capacitors | ATC600F120JT250XT | ATC |
| C13 | 8.2 pF Chip Capacitor | ATC600F8R2BT250XT | ATC |
| C14 | 20 pF Chip Capacitor | ATC600F200JT250XT | ATC |
| C15 | 2 pF Chip Capacitor | ATC600F2R0BT250XT | ATC |
| C17 | 47 pF Chip Capacitor | ATC600F470JT250XT | ATC |
| J1 | 3-pin Header | 22-28-8360 | Molex |
| L1 | 2.55 nH Inductor | 0906-3JLC | Coilcraft |
| L2 | 3.85 nH Inductor | 0906-4JLC | Coilcraft |
| L3 | 22 nH Inductor | 0908SQ22N | Coilcraft |
| L4, L5 | 17 nH Inductors | 0908SQ17N | Coilcraft |
| L6 | 1.65 nH Inductor | 0906-2JLC | Coilcraft |
| L7 | 8.1 nH Inductor | 0908SQ8R1N | Coilcraft |
| R1 | 22 Ω , 1/10 W Chip Resistor | RR1220Q-220-D | Susumu |
| Q1 | RF Power LDMOS Transistor | MMRF1021NT1 | Freescale |
| PCB | Shengyi S1000-2, 0.020", $\epsilon_r = 4.8$ | — | MTL |

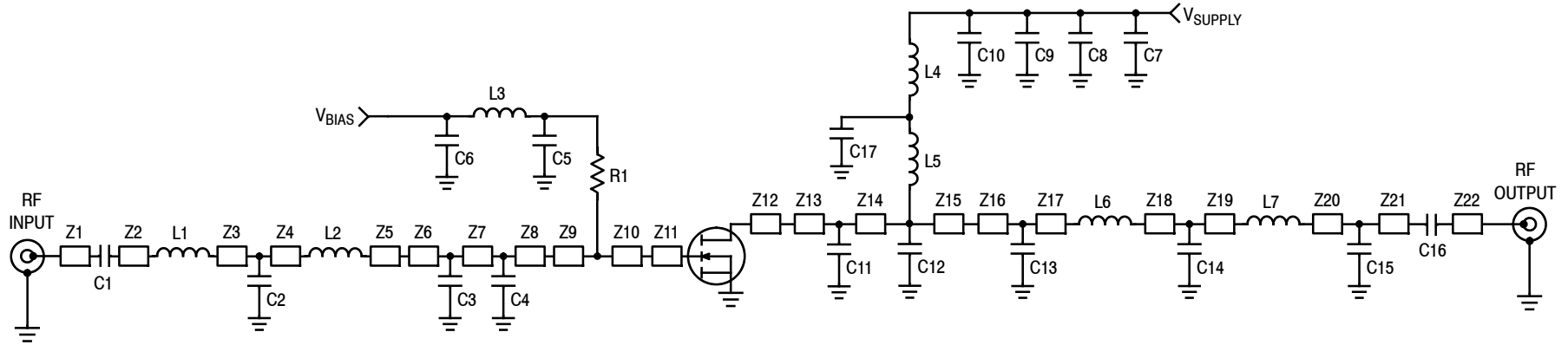

Figure 17. MMRF1021NT1 UHF Broadband Reference Circuit Schematic — 450–520 MHz

Table 15. MMRF1021NT1 UHF Broadband Reference Circuit Microstrips — 450–520 MHz

| Microstrip | Description | Microstrip | Description | Microstrip | Description |
|------------|----------------------------|------------|----------------------------|------------|----------------------------|
| Z1 | 0.060" × 0.034" Microstrip | Z9 | 0.121" × 0.300" Microstrip | Z16 | 0.075" × 0.049" Microstrip |
| Z2 | 0.052" × 0.046" Microstrip | Z10 | 0.031" × 0.300" Microstrip | Z17 | 0.279" × 0.049" Microstrip |
| Z3 | 0.110" × 0.046" Microstrip | Z11 | 0.070" × 0.146" Microstrip | Z18 | 0.032" × 0.046" Microstrip |
| Z4 | 0.118" × 0.046" Microstrip | Z12 | 0.070" × 0.146" Microstrip | Z19 | 0.195" × 0.046" Microstrip |
| Z5 | 0.084" × 0.046" Microstrip | Z13 | 0.138" × 0.170" Microstrip | Z20 | 0.089" × 0.046" Microstrip |
| Z6 | 0.124" × 0.046" Microstrip | Z14 | 0.055" × 0.170" Microstrip | Z21 | 0.046" × 0.046" Microstrip |
| Z7 | 0.084" × 0.046" Microstrip | Z15 | 0.055" × 0.170" Microstrip | Z22 | 0.060" × 0.034" Microstrip |
| Z8 | 0.207" × 0.046" Microstrip | | | | |

TYPICAL CHARACTERISTICS — 450–520 MHz UHF BROADBAND REFERENCE CIRCUIT

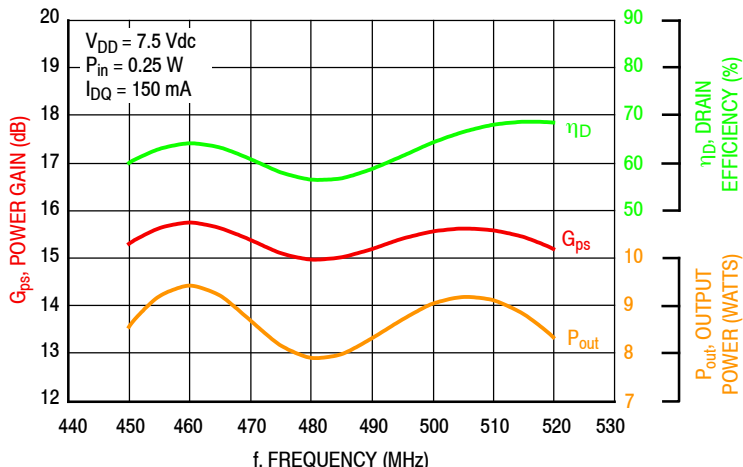

Figure 18. Power Gain, Output Power and Drain Efficiency versus Frequency at a Constant Input Power — 7.5 V

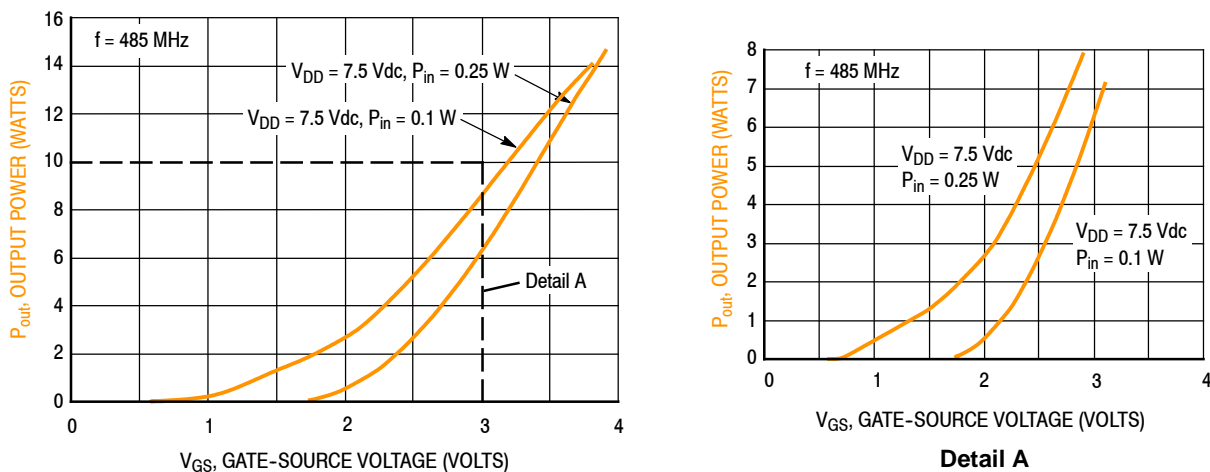

Figure 19. Output Power versus Gate-Source Voltage

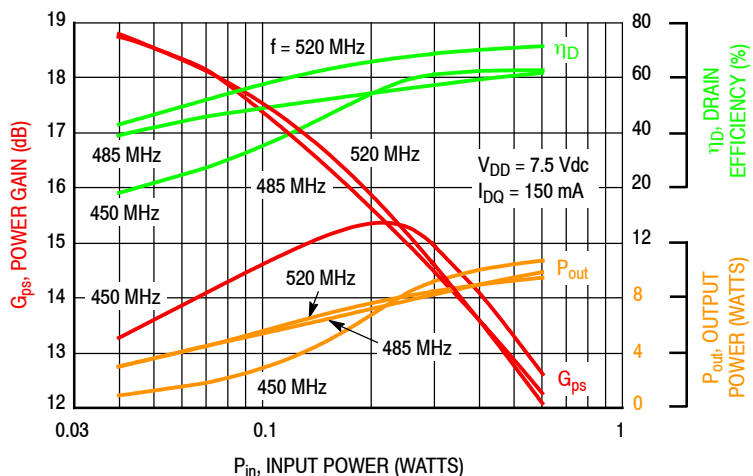
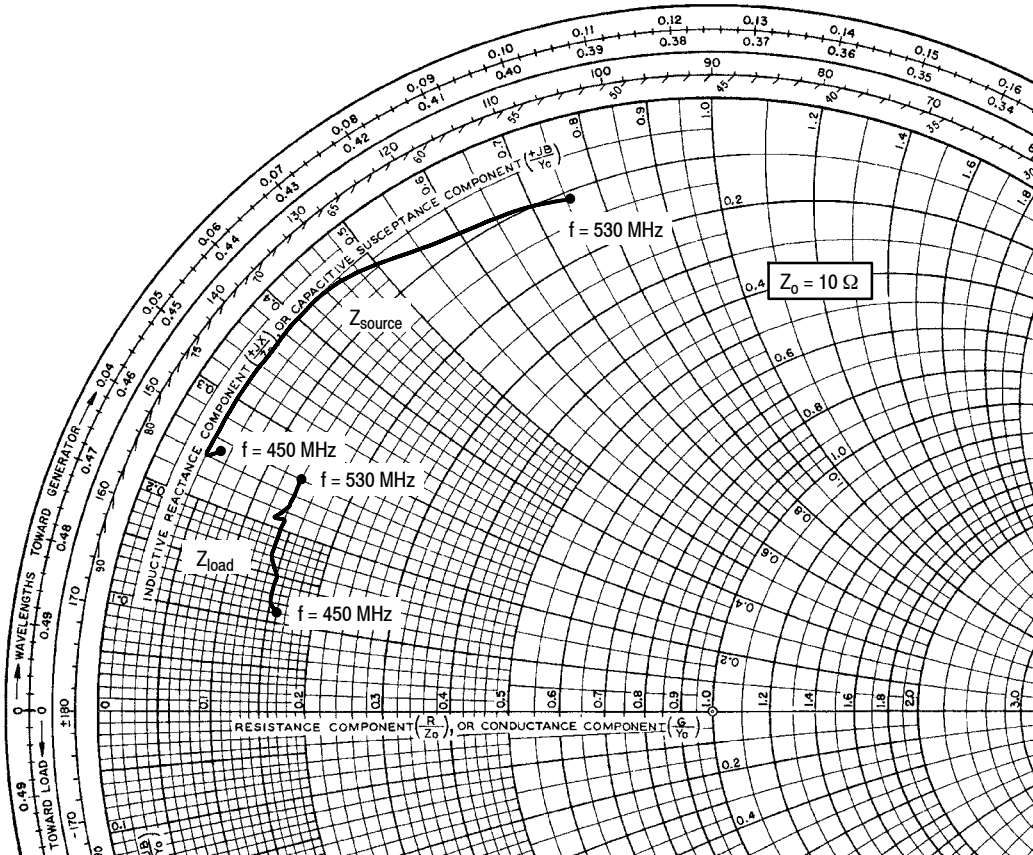

Figure 20. Power Gain, Output Power and Drain Efficiency versus Input Power and Frequency

450–520 MHz UHF BROADBAND REFERENCE CIRCUIT



$V_{DD} = 7.5 \text{ Vdc}$, $I_{DQ} = 150 \text{ mA}$, $P_{out} = 7.5 \text{ W}$

| f MHz | Z_{source} Ω | Z_{load} Ω |
|----------|--------------------------|------------------------|
| 450 | $0.45 + j2.46$ | $1.56 + j1.05$ |
| 460 | $0.40 + j2.37$ | $1.52 + j1.24$ |
| 470 | $0.40 + j2.97$ | $1.46 + j1.51$ |
| 480 | $0.38 + j3.56$ | $1.39 + j1.71$ |
| 490 | $0.41 + j4.16$ | $1.35 + j2.06$ |
| 500 | $0.51 + j4.79$ | $1.34 + j2.06$ |
| 510 | $0.70 + j5.54$ | $1.37 + j2.30$ |
| 520 | $0.93 + j6.44$ | $1.40 + j2.50$ |
| 530 | $1.14 + j7.56$ | $1.42 + j2.62$ |

Z_{source} = Test circuit impedance as measured from gate to ground.

Z_{load} = Test circuit impedance as measured from drain to ground.

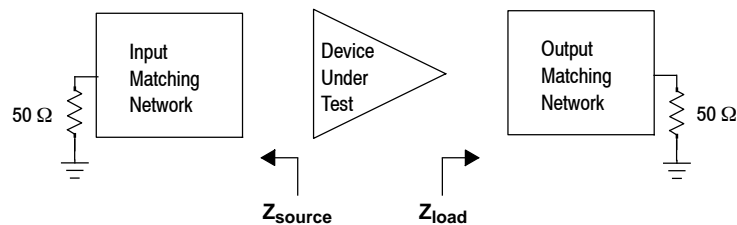

Figure 21. UHF Broadband Series Equivalent Source and Load Impedance — 450–520 MHz

760–860 MHz BROADBAND REFERENCE CIRCUIT

Table 16. 760–860 MHz Broadband Performance (In Freescale Reference Circuit, 50 ohm system)

$V_{DD} = 7.5 V_{DC}$, $I_{DQ} = 150 \text{ mA}$, $T_A = 25^\circ\text{C}$, CW

| Frequency (MHz) | P_{in} (W) | G_{ps} (dB) | η_D (%) | P_{out} (W) |
|-----------------|--------------|---------------|--------------|---------------|
| 760 | 0.20 | 15.3 | 48.1 | 7.0 |
| 810 | 0.16 | 16.3 | 54.1 | 7.0 |
| 860 | 0.21 | 15.1 | 59.5 | 7.0 |

Table 17. Load Mismatch/Ruggedness (In Freescale Reference Circuit)

| Frequency (MHz) | Signal Type | VSWR | P_{in} (W) | Test Voltage, V_{DD} | Result |
|-----------------|-------------|----------------------------|----------------------|------------------------|-----------------------|
| 810 | CW | > 65:1 at all Phase Angles | 0.5 (3 dB Overdrive) | 9.0 | No Device Degradation |

760–860 MHz BROADBAND REFERENCE CIRCUIT

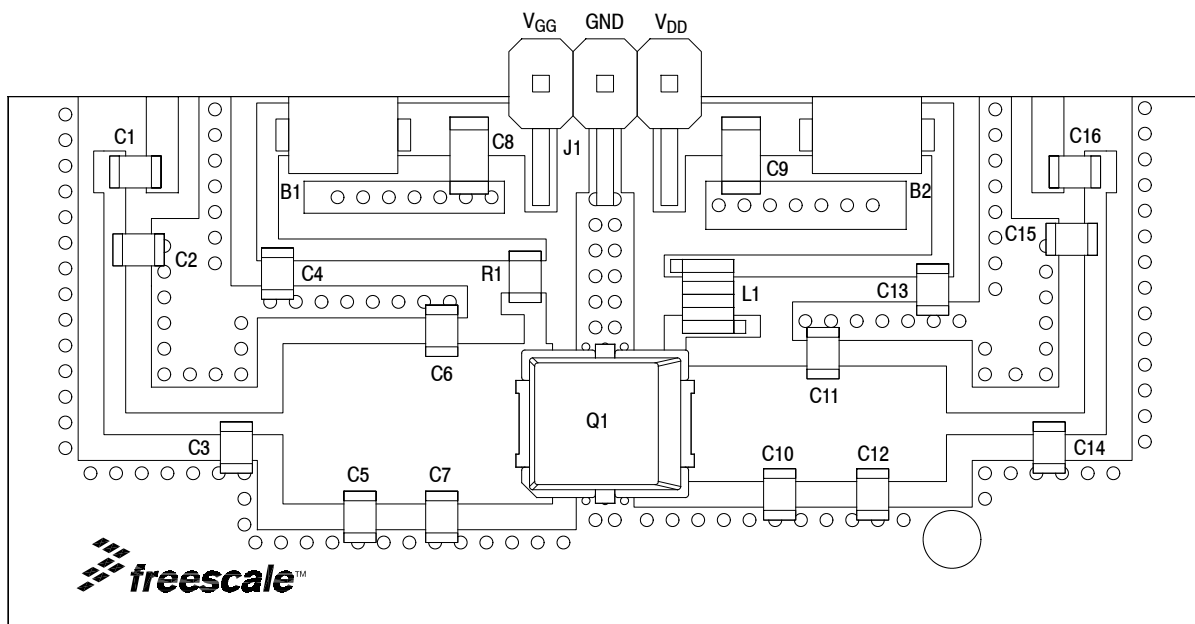

Figure 22. MMRF1021NT1 Broadband Reference Circuit Component Layout — 760–860 MHz

Table 18. MMRF1021NT1 Broadband Reference Circuit Component Designations and Values — 760–860 MHz

| Part | Description | Part Number | Manufacturer |
|--------------|---|--------------------|--------------|
| B1, B2 | RF Beads | 2743019447 | Fair-Rite |
| C1 | 10 pF Chip Capacitor | GQM2195C2E100FB15 | Murata |
| C2 | 3.9 pF Chip Capacitor | GQM2195C2E3R9BB15 | Murata |
| C3 | 7.5 pF Chip Capacitor | GQM2195C2E7R5BB15 | Murata |
| C4, C13, C16 | 100 pF Chip Capacitors | GQM2195C2E101GB15 | Murata |
| C5 | 8.2 pF Chip Capacitor | GQM2195C2E8R2BB15 | Murata |
| C6, C7 | 20 pF Chip Capacitors | GQM2195C2E200GB15 | Murata |
| C8 | 1 μ F Chip Capacitor | GRM31MR71H105KA88L | Murata |
| C9 | 10 μ F Chip Capacitor | GRM31CR61H106KA12L | Murata |
| C10, C11 | 12 pF Chip Capacitors | GQM2195C2E120FB15 | Murata |
| C12 | 5.1 pF Chip Capacitor | GQM2195C2E5R1BB15 | Murata |
| C14 | 4.7 pF Chip Capacitor | GQM2195C2E4R7BB15 | Murata |
| C15 | 3.9 pF Chip Capacitor | GQM2195C2E3R9BB15 | Murata |
| J1 | 3-pin Header | 22-28-8360 | Molex |
| L1 | 22 nH Inductor | 0908SQ-22NJL | Coilcraft |
| Q1 | RF Power LDMOS Transistor | MMRF1021NT1 | Freescale |
| R1 | 200 Ω Chip Resistor | CRCW0805200RJNEA | Vishay |
| PCB | Shengyi S1000-2, 0.020", $\epsilon_r = 4.8$ | — | MTL |

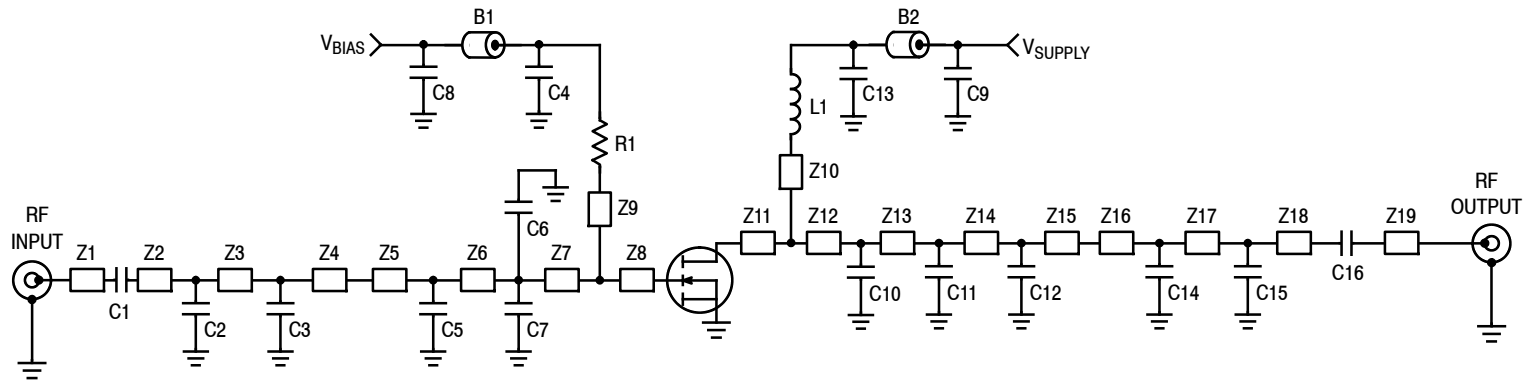

Figure 23. MMRF1021NT1 Broadband Reference Circuit Schematic — 760–860 MHz

Table 19. MMRF1021NT1 Broadband Reference Circuit Microstrips — 760–860 MHz

| Microstrip | Description | Microstrip | Description | Microstrip | Description |
|------------|----------------------------|------------|----------------------------|------------|----------------------------|
| Z1 | 0.150" × 0.050" Microstrip | Z8 | 0.027" × 0.250" Microstrip | Z15 | 0.115" × 0.180" Microstrip |
| Z2 | 0.120" × 0.034" Microstrip | Z9 | 0.066" × 0.034" Microstrip | Z16 | 0.160" × 0.034" Microstrip |
| Z3 | 0.460" × 0.034" Microstrip | Z10 | 0.110" × 0.034" Microstrip | Z17 | 0.360" × 0.034" Microstrip |
| Z4 | 0.073" × 0.034" Microstrip | Z11 | 0.027" × 0.180" Microstrip | Z18 | 0.105" × 0.034" Microstrip |
| Z5 | 0.120" × 0.250" Microstrip | Z12 | 0.163" × 0.180" Microstrip | Z19 | 0.150" × 0.050" Microstrip |
| Z6 | 0.128" × 0.250" Microstrip | Z13 | 0.068" × 0.180" Microstrip | | |
| Z7 | 0.145" × 0.250" Microstrip | Z14 | 0.077" × 0.180" Microstrip | | |

* Line length includes microstrip bends.

TYPICAL CHARACTERISTICS — 760–860 MHz BROADBAND REFERENCE CIRCUIT

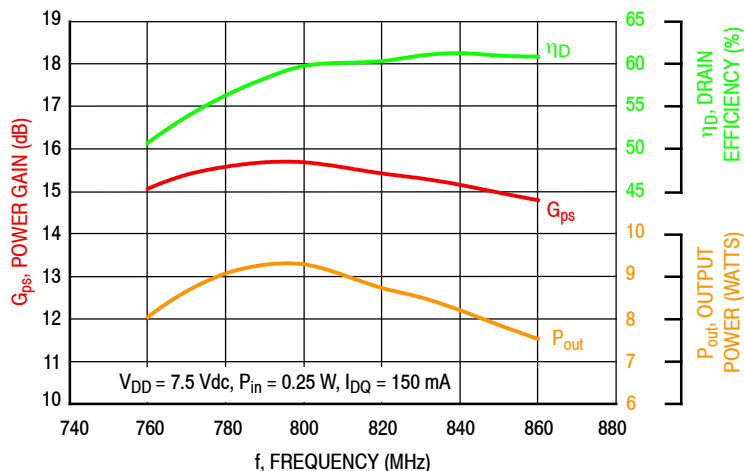

Figure 24. Power Gain, Output Power and Drain Efficiency versus Frequency at a Constant Input Power — 7.5 V

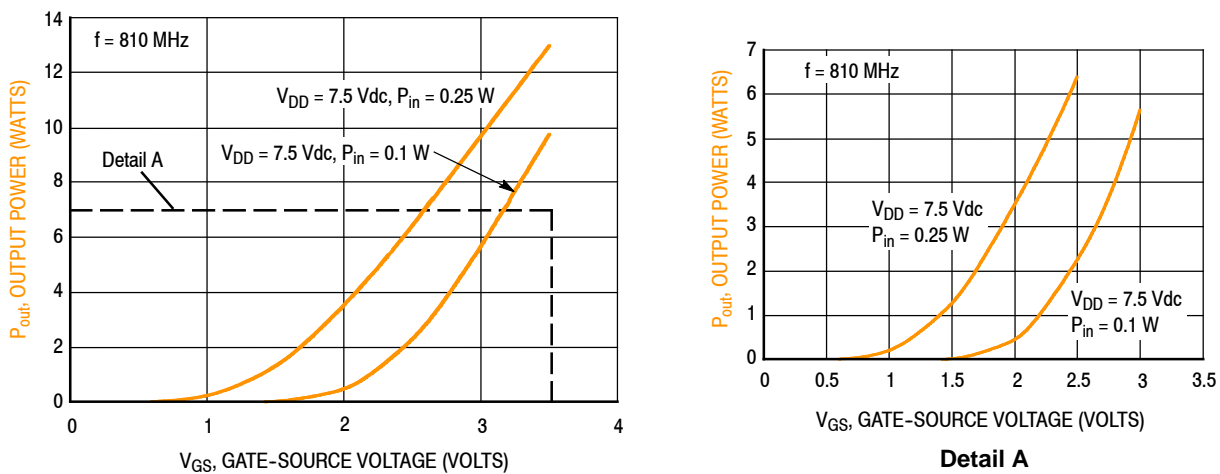

Figure 25. Output Power versus Gate-Source Voltage

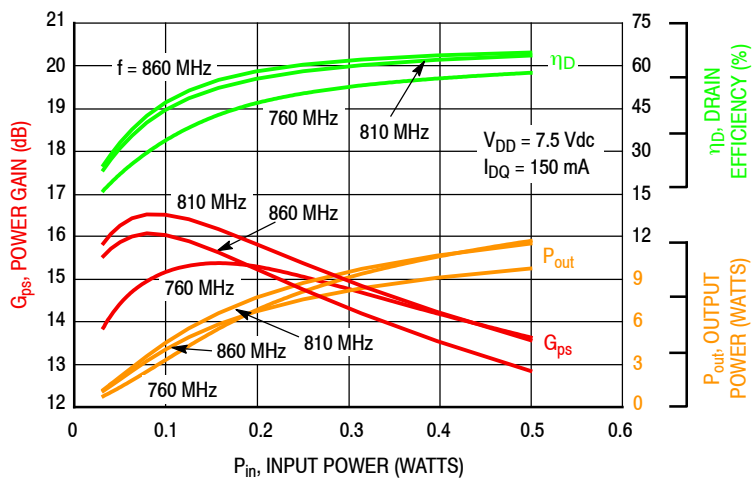
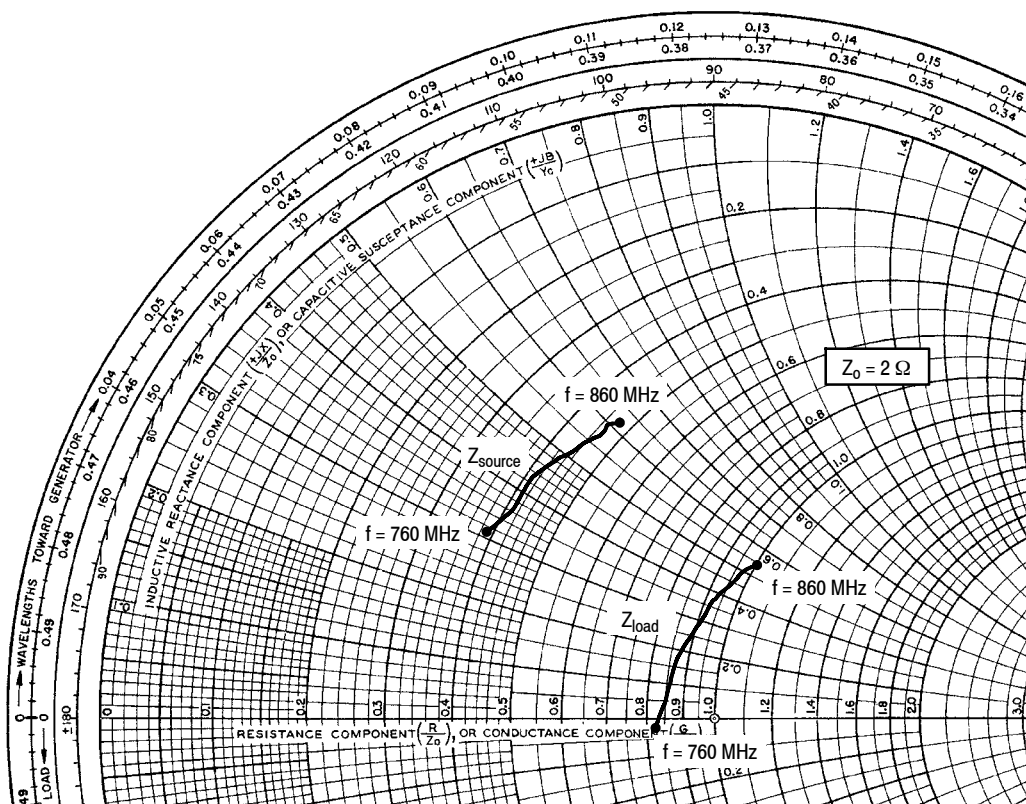

Figure 26. Power Gain, Output Power and Drain Efficiency versus Input Power and Frequency

760–860 MHz BROADBAND REFERENCE CIRCUIT



$V_{DD} = 7.5 \text{ Vdc}$, $I_{DQ} = 150 \text{ mA}$, $P_{out} = 7 \text{ W}$

| f MHz | Z_{source} Ω | Z_{load} Ω |
|------------------|--|--|
| 760 | $0.77 + j0.62$ | $1.65 - j0.04$ |
| 770 | $0.81 + j0.71$ | $1.70 + j0.10$ |
| 780 | $0.81 + j0.79$ | $1.72 + j0.24$ |
| 790 | $0.82 + j0.85$ | $1.74 + j0.36$ |
| 800 | $0.84 + j0.92$ | $1.77 + j0.49$ |
| 810 | $0.85 + j0.98$ | $1.81 + j0.61$ |
| 820 | $0.88 + j1.02$ | $1.84 + j0.69$ |
| 830 | $0.89 + j1.07$ | $1.87 + j0.79$ |
| 840 | $0.91 + j1.13$ | $1.91 + j0.90$ |
| 850 | $0.91 + j1.19$ | $1.93 + j0.99$ |
| 860 | $0.94 + j1.23$ | $1.99 + j1.08$ |

Z_{source} = Test circuit impedance as measured from gate to ground.

Z_{load} = Test circuit impedance as measured from drain to ground.

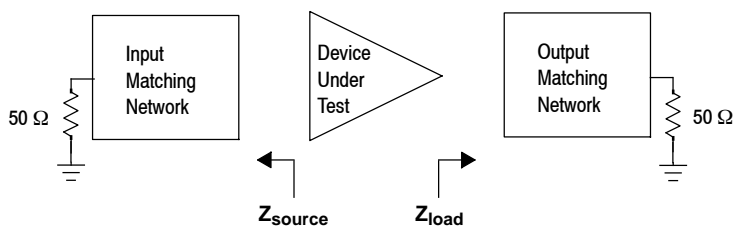

Figure 27. Broadband Series Equivalent Source and Load Impedance — 760–860 MHz

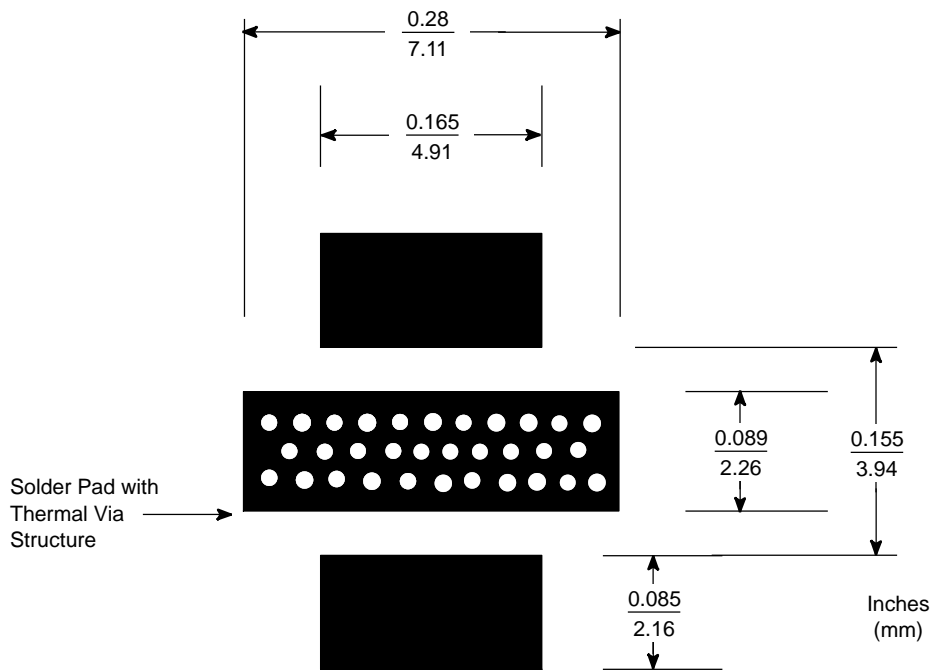

Figure 28. PCB Pad Layout for PLD-1.5W

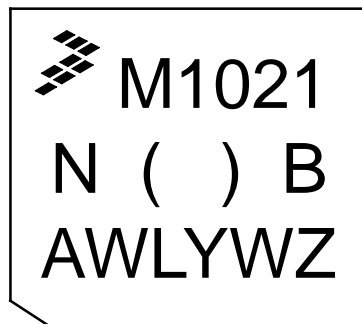
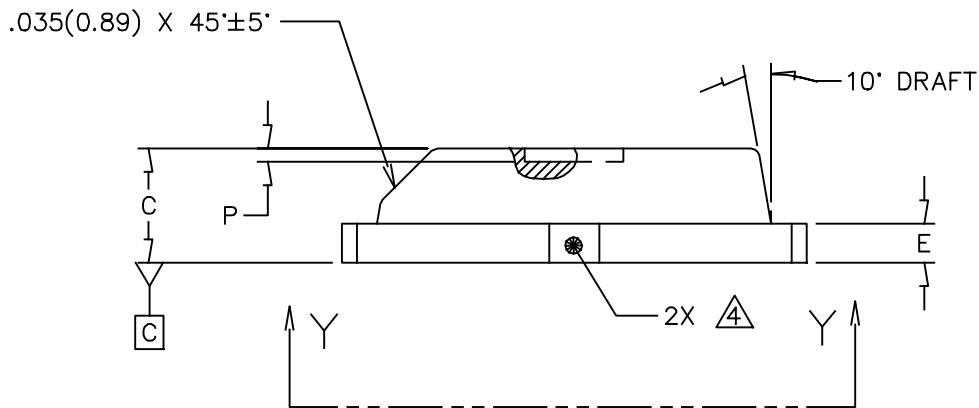
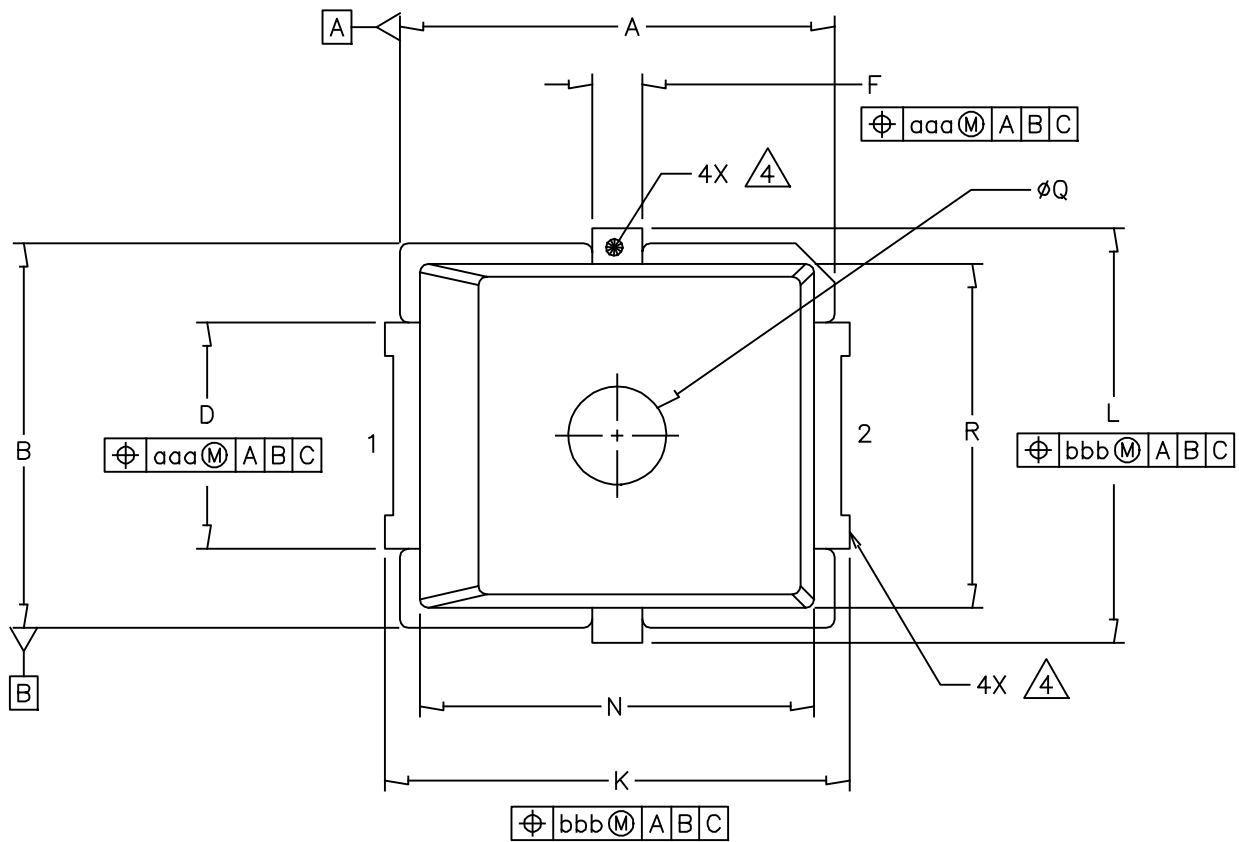
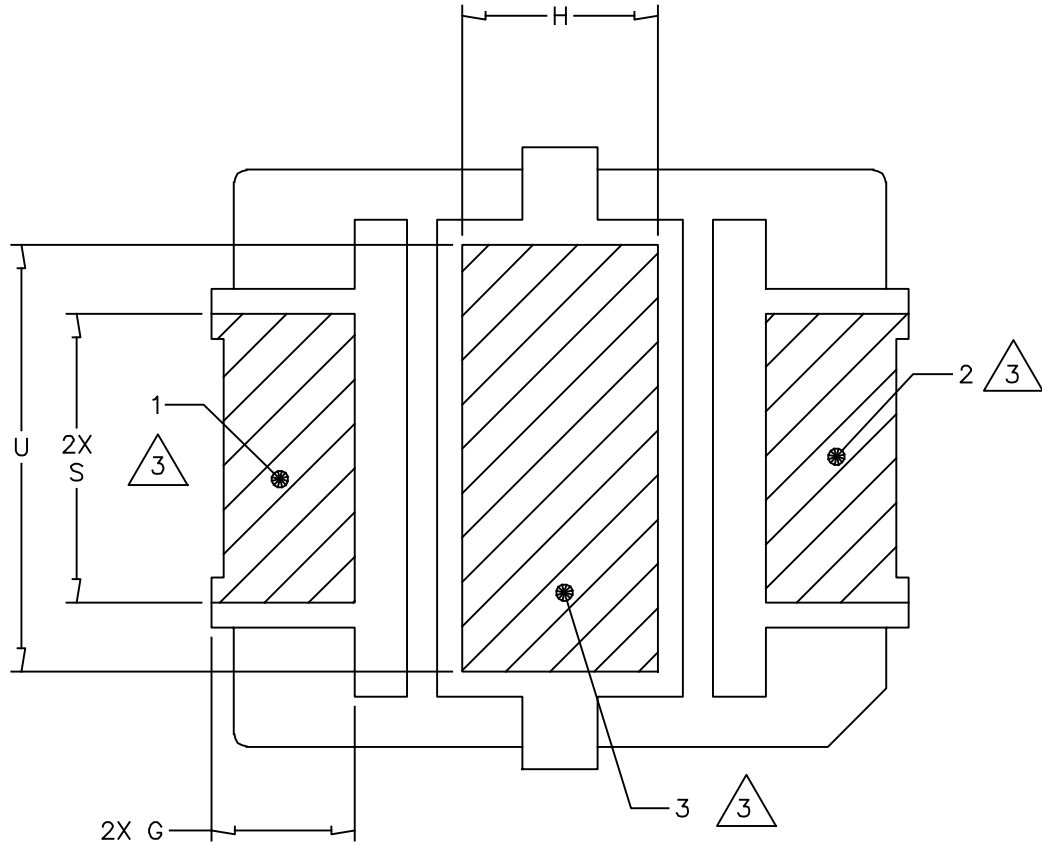

Figure 29. Product Marking

PACKAGE DIMENSIONS



| | | | |
|---|--------------------------|----------------------------|--|
| © FREESCALE SEMICONDUCTOR, INC. ALL RIGHTS RESERVED. | MECHANICAL OUTLINE | PRINT VERSION NOT TO SCALE | |
| TITLE: PLD-1.5W | DOCUMENT NO: 98ASA00476D | REV: 0 | |
| | CASE NUMBER: 2297-01 | 14 JUN 2012 | |
| | STANDARD: NON-JEDEC | | |



VIEW Y-Y

| | | | |
|---|--------------------------|----------------------------|--|
| © FREESCALE SEMICONDUCTOR, INC. ALL RIGHTS RESERVED. | MECHANICAL OUTLINE | PRINT VERSION NOT TO SCALE | |
| TITLE: PLD-1.5W | DOCUMENT NO: 98ASA00476D | REV: 0 | |
| | CASE NUMBER: 2297-01 | 14 JUN 2012 | |
| | STANDARD: NON-JEDEC | | |

NOTES:

1. CONTROLLING DIMENSION: INCH.
2. INTERPRET DIMENSIONS AND TOLERANCES PER ASME Y14.5M-1994.

3. HATCHING REPRESENTS THE EXPOSED AND SOLDERABLE AREA. DIMENSIONS G, S, H AND U REPRESENT THE VALUES BETWEEN THE TWO OPPOSITE POINTS ALONG THE EDGES OF EXPOSED AREA.

4. THESE SURFACES ARE NOT PART OF THE SOLDERABLE SURFACES AND MAY REMAIN UNPLATED.

| DIM | INCH | | MILLIMETER | | DIM | INCH | | MILLIMETER | |
|---|------|------|--------------------|------|--------------------------|----------------------------|------|-------------|------|
| | MIN | MAX | MIN | MAX | | MIN | MAX | MIN | MAX |
| A | .255 | .265 | 6.48 | 6.73 | Q | .055 | .063 | 1.40 | 1.60 |
| B | .225 | .235 | 5.72 | 5.97 | R | .200 | .210 | 5.08 | 5.33 |
| C | .065 | .072 | 1.65 | 1.83 | S | .110 | — | 2.79 | — |
| D | .130 | .150 | 3.30 | 3.81 | U | .156 | — | 3.96 | — |
| E | .021 | .026 | 0.53 | 0.66 | aaa | | .004 | | 0.10 |
| F | .026 | .044 | 0.66 | 1.12 | bbb | | .005 | | 0.13 |
| G | .038 | — | 0.97 | — | | | | | |
| H | .069 | — | 1.75 | — | | | | | |
| J | .160 | .180 | 4.06 | 4.57 | | | | | |
| K | .273 | .285 | 6.93 | 7.24 | | | | | |
| L | .245 | .255 | 6.22 | 6.48 | | | | | |
| N | .230 | .240 | 5.84 | 6.10 | | | | | |
| P | .000 | .008 | 0.00 | 0.20 | | | | | |
| © FREESCALE SEMICONDUCTOR, INC. ALL RIGHTS RESERVED. | | | MECHANICAL OUTLINE | | | PRINT VERSION NOT TO SCALE | | | |
| TITLE: PLD-1.5W | | | | | DOCUMENT NO: 98ASA00476D | | | REV: 0 | |
| | | | | | CASE NUMBER: 2297-01 | | | 14 JUN 2012 | |
| | | | | | STANDARD: NON-JEDEC | | | | |

PRODUCT DOCUMENTATION AND SOFTWARE

Refer to the following resources to aid your design process.

Application Notes

- AN1955: Thermal Measurement Methodology of RF Power Amplifiers

Engineering Bulletins

- EB212: Using Data Sheet Impedances for RF LDMOS Devices

Software

- Electromigration MTTF Calculator

For Software, do a Part Number search at <http://www.freescale.com>, and select the "Part Number" link. Go to the Software & Tools tab on the part's Product Summary page to download the respective tool.

REVISION HISTORY

The following table summarizes revisions to this document.

| Revision | Date | Description |
|----------|-----------|---|
| 0 | July 2014 | <ul style="list-style-type: none">• Initial Release of Data Sheet |

How to Reach Us:

Home Page:
freescale.com

Web Support:
freescale.com/support

Information in this document is provided solely to enable system and software implementers to use Freescale products. There are no express or implied copyright licenses granted hereunder to design or fabricate any integrated circuits based on the information in this document.

Freescale reserves the right to make changes without further notice to any products herein. Freescale makes no warranty, representation, or guarantee regarding the suitability of its products for any particular purpose, nor does Freescale assume any liability arising out of the application or use of any product or circuit, and specifically disclaims any and all liability, including without limitation consequential or incidental damages. "Typical" parameters that may be provided in Freescale data sheets and/or specifications can and do vary in different applications, and actual performance may vary over time. All operating parameters, including "typicals," must be validated for each customer application by customer's technical experts. Freescale does not convey any license under its patent rights nor the rights of others. Freescale sells products pursuant to standard terms and conditions of sale, which can be found at the following address: freescale.com/SalesTermsandConditions.

Freescale and the Freescale logo are trademarks of Freescale Semiconductor, Inc., Reg. U.S. Pat. & Tm. Off. Airfast is a trademark of Freescale Semiconductor, Inc. All other product or service names are the property of their respective owners.

© 2014 Freescale Semiconductor, Inc.

