

Nutaq MI250

High-speed, multichannel A/D FMC
PRODUCT SHEET

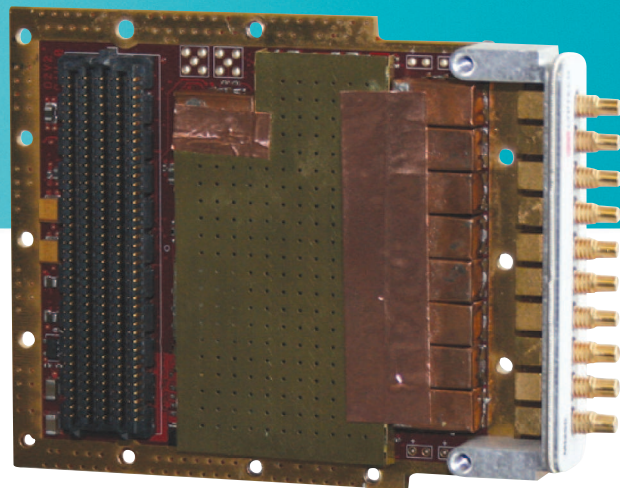

RoHS

Nutaq[®] Scientific

QUEBEC | MONTREAL | NEW YORK | nutaq.com

Nutaq MI250

- 8 channels
- 250 MSPS, 14-bit A/D
- Supports multiple clock and reference configurations

- Versatile and industry-standard VITA 57.1 FMC
- Perfect for Nutaq's μ TCA Perseus AMCs

The MI250 FPGA mezzanine card (FMC) is equipped with eight A/D conversion channels and fully complies with the VITA 57.1 standard. The MI250's eight, 14-bit, 250 MSPS conversion channels can be sampled by an internal clock source (that can be locked onto an external reference) or an external sample clock. A trigger input is also available for customized sampling control.

The MI250 is equipped with a high-pin-count (HPC) connector and front panel I/Os, and is designed around Texas Instruments' ADS62P49 dual-channel, 14-bit, 250 MSPS A/D converter. The analog signal inputs can be AC or DC coupled and they are connected to the SSMC coaxial connectors on the front panel of the card.

The MI250 allows flexible sampling frequency, analog input gain, and offset correction control through serial communications with an AMC. Further, the card is equipped with a power supply and temperature monitoring system, as well as several power-down modes to deactivate unused functions.

FEATURES

- Eight, 14-bit, 250 MSPS A/D conversion channels
- Complies with VITA 57.1
- Designed around the ADS62P49 from Texas Instruments
- Front-panel, coaxial inputs on SSMC connectors
- AC-coupled or DC-coupled analog inputs
- 400-pin, HPC connector
- Flexible clock tree:
 - Internal clock
 - External clock

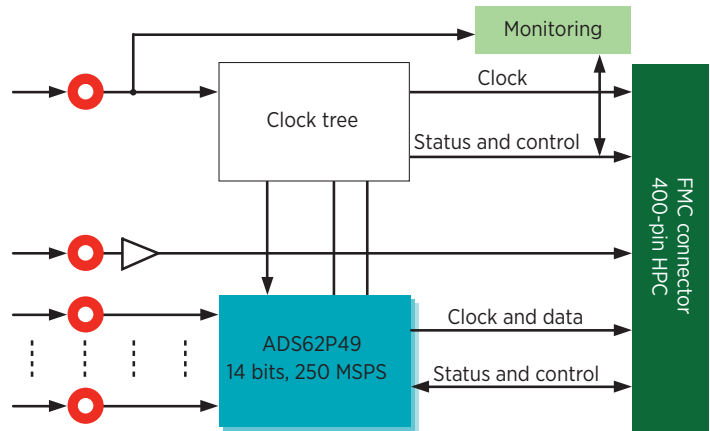

PERFORMANCE

- AC bandwidth: 650 MHz
- DC bandwidth: 125 MHz
- Crosstalk: 80 dB
- Analog inputs ($1 V_{pp}$ or $2 V_{pp}$): 4 dBm to 10 dBm
- Clock input range: -12.5 dBm to 10 dBm
- Trigger: LVTTTL/LVCMOS (TTL compliant)
- Programmable gain: 0-6 dB
- Offset correction: ± 10 mV

AC-coupled performance

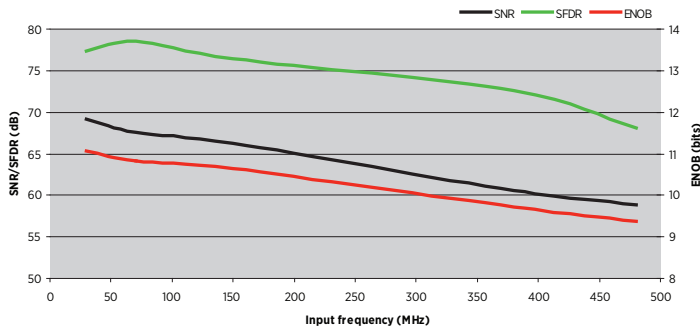

DC-coupled performance

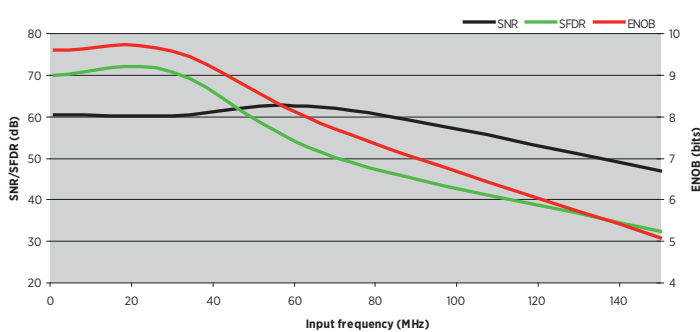

TARGET APPLICATIONS

- MIMO systems
- Beamforming
- Wireless communication receivers
- Medical imaging (PET, ultrasounds)
- Test measurement instruments
- Scientifics (particle accelerators, astronomy)

SPECIFICATIONS

FMC connectivity

- High pin-count connector
- LA (00-33), HA (00-23), HB (00-16)
- CLK0: M2C clock

Front panel

- SSMC connectors
- A/D channels A-H ×8
- External trigger
- External reference/sampling clock input

Mechanical

- Dimensions: 69.0 mm × 15.0 mm × 87.5 mm (W×H×D)
- Rugged FMC form factor — designed for conduction cooling. Contact Nutaq for details.

Standards compliance

- VITA 57.1

Electrical

- 12 V
- 3.3 V
- 2.5 V (V_{adj})

Power consumption

- 3.3 V power supply: maximum 10 W
- 12 V power supply: maximum 12 W
- 2.5 V (V_{adj}) power supply: maximum 12.3 W

Environmental

- Operating temperature: 0°C to 70°C
- Storage temperature: -50°C to 125°C
- Operating humidity: 0% to 100%, non-condensing
- Storage humidity: 0% to 100%
- Vibration: 0.1 g²/Hz, 10 Hz to 3 kHz
- Shock: 30 g peak



INNOVATION TODAY
FOR TOMORROW®

2150 Cyrille-Duquet, Quebec City (Quebec) G1N 2G3 CANADA
T. 418-914-7484 | 1-855-914-7484 | F. 418-914-9477
info@nutaq.com

Nutaq products are constantly being improved; therefore, Nutaq reserves itself the right to modify the information herein at any time and without notice.