

DSPE-BF-IP

VoIP Front-end with PoE

Overview

DSPECIALISTS' VoIP front-end module DSPE-BF-IP is a compact DSP module based on the 600 MHz Analog Devices Blackfin BF-537. It allows processing of analog audio signals with sample rates of 8 kHz up to 192 kHz and 24 Bit. This module is focussed on applications where audio streaming via Ethernet in TCP/IP networks is required.

Due to its flexible power supply through the PoE-capable (IEEE802.3af class 3) Ethernet interface or the dedicated 12-30V DC connector it can be easily embedded into any customer-specific environment.

DSPE-BF-IP covers a wide range of embedded telecommunication tasks like noise cancellation, echo cancellation, Voice over IP and audio distribution in IP networks.

The board is accompanied with hardware drivers and a software framework. Software for echo cancellation and noise cancellation is also available and can be licensed in a bundle with the hardware board.

DSPE-BF-IP can be easily extended for other network applications like high-precision audio or video transmission over Internet protocol.

Block Diagram

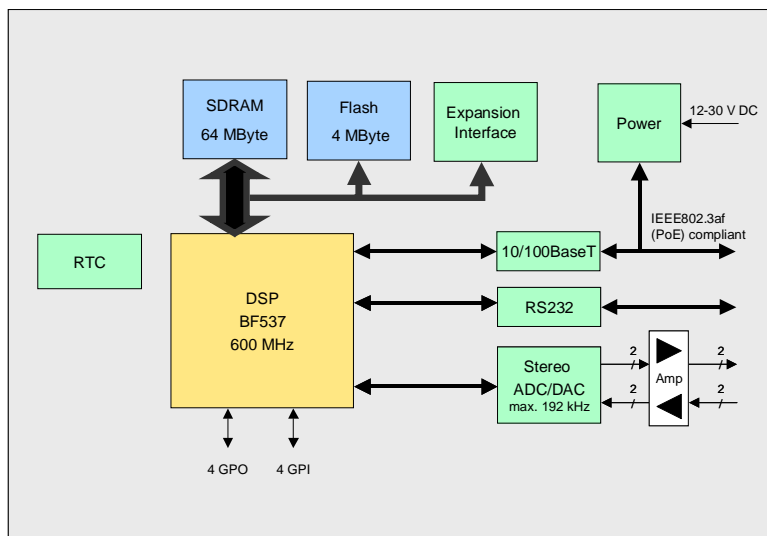

Key Features

- Stand-alone 600 MHz 16-Bit DSP system
- Stereo analog input and output
- Ethernet interface for audio transmission and control
- IEEE802.3af class 3 compliant Ethernet interface (Power-over-Ethernet)
- Open System μ C Linux
- Echo cancellation algorithm
- Noise cancellation algorithm
- Adaptable to customer-specific hardware
- Software framework for customer-specific algorithms
- Parameter input via PC user interface

mass customization • state-of-the-art DSP technology • OEM delivery

Technical Specification

- Processor ADSP-BF537 500/600 MHz
- SDRAM 32M x 16 / 133 MHz / CL2
- Flash 4M x 8 / 90 ns
- Audio Channels 2 in / 2 out on 3.5 mm stereo jacks
- AD/DA Converter AC97 codec, optional : HD codec
- Sample rate up to 192 kHz, up to 24 bit
- Level 1 V_{rms} / single ended, microphone phantom power
- Ethernet RJ45 10/100BaseT, IEEE802.3af compliant (PoE) – class 3
- Serial interface RS232
- Debugging interface JTAG
- RTC optional: real-time clock, battery buffered
- LED 4 software controllable, 1 power-good
- GPIO 4 input / output on pin header
- Power supply 12 VDC .. 30 VDC / 3 Watt (dedicated power input and PoE / 12 W)
- Outline 140 mm x 80 mm
- Expansion interface Analog audio (balanced), I²S, TDM, SPI, I²C, video interface, GPIO, 2nd UART

mass customization • state-of-the-art DSP technology • OEM delivery

CONTACT:

DSPECIALISTS
Digitale Audio- und Messsysteme GmbH
Helmholtzstr. 2-9 L
10587 Berlin
Germany

ABOUT US

The products of DSPECIALISTS are distinguishable by the use of proven standard components. All products can be adapted to our clients' individual wishes. DSPECIALISTS offers anything from the development of customer-specific modules to complete systems. Aside from DSPs, we also make use of PC's, micro controllers and programmable logic.

Tel: +49 30 467805-0
Fax: +49 30 467805-99
E-mail: sales@dspecialists.de

VISIT OUR WEBSITE
www.dspecialists.de

DSPECIALISTS

Digitale Audio- und Messsysteme GmbH