

BLF3G21-30

UHF power LDMOS transistor

Rev. 01 — 14 February 2007

Product data sheet

1. Product profile

1.1 General description

30 W LDMOS power transistor for base station applications at frequencies from HF to 2200 MHz.

Table 1. Typical class-AB RF performance

$I_{Dq} = 450 \text{ mA}$; $T_h = 25^\circ\text{C}$ in a common source test circuit.

Mode of operation	f (MHz)	P_L (W)	G_p (dB)	η_D (%)	IMD3 (dB)	$P_{L(1dB)}$ (W)
CW	2000	36	12.5	43	-	36
Two-tone	2000	30	13.5	35	-26	-
		0.1 to 10	13.8	-	< -50	-

Table 2. Typical class-A RF performance

$I_{Dq} = 1 \text{ A}$; $T_h = 25^\circ\text{C}$ in a modified PHS test fixture.

Mode of operation	f (MHz)	$P_{L(AV)}$ (W)	G_p (dB)	η_D (%)	ACPR ₆₀₀ (dBc)
PHS	1880 to 1920	9	16	20	-75

CAUTION



This device is sensitive to ElectroStatic Discharge (ESD). Therefore care should be taken during transport and handling.

1.2 Features

- Excellent back-off linearity
- Typical PHS performance at a supply voltage of 26 V and I_{Dq} of 1 A:
 - ◆ Average output power = 9 W
 - ◆ Gain = 16 dB (typ)
 - ◆ Efficiency = 20 %
 - ◆ ACPR₆₀₀ = -75 dBc
- Easy power control
- Excellent ruggedness
- High power gain
- Excellent thermal stability
- Designed for broadband operation (HF to 2200 MHz)

- No internal matching for broadband operation
- ESD protection

1.3 Applications

- RF power amplifiers for GSM, PHS, EDGE, CDMA and W-CDMA base stations and multicarrier applications in the HF to 2200 MHz frequency range
- Broadcast drivers

2. Pinning information

Table 3. Pinning

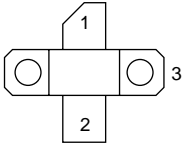
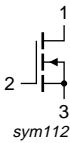
Pin	Description	Simplified outline	Symbol
1	drain		 sym112
2	gate		
3	source		

[1] Connected to flange

3. Ordering information

Table 4. Ordering information

Type number	Package		
	Name	Description	Version
BLF3G21-30	-	flanged LDMOST ceramic package; 2 mounting holes; 2 leads	SOT467C

4. Limiting values

Table 5. Limiting values

In accordance with the Absolute Maximum Rating System (IEC 60134).

Symbol	Parameter	Conditions	Min	Max	Unit
V_{DS}	drain-source voltage		-	65	V
V_{GS}	gate-source voltage		-	±15	V
I_D	drain current		-	4.5	A
T_{stg}	storage temperature		-65	+150	°C
T_j	junction temperature		-	200	°C

5. Thermal characteristics

Table 6. Thermal characteristics

Symbol	Parameter	Conditions	Typ	Unit
$R_{th(j-c)}$	thermal resistance from junction to case	$T_h = 25\text{ °C}; P_{L(AV)} = 15\text{ W}$	[1] 1.6	K/W
$R_{th(j-h)}$	thermal resistance from junction to heatsink	$T_h = 25\text{ °C}; P_{L(AV)} = 15\text{ W}$	[2] 2.1	K/W

[1] Thermal resistance is determined under specified RF operating conditions

[2] Depending on mounting condition in application

6. Characteristics

Table 7. Characteristics

$T_j = 25\text{ °C}$ unless otherwise specified.

Symbol	Parameter	Conditions	Min	Typ	Max	Unit
$V_{(BR)DSS}$	drain-source breakdown voltage	$V_{GS} = 0\text{ V}; I_D = 0.7\text{ mA}$	65	-	-	V
$V_{GS(th)}$	gate-source threshold voltage	$V_{DS} = 10\text{ V}; I_D = 70\text{ mA}$	2.0	-	3.0	V
I_{DSS}	drain leakage current	$V_{GS} = 0\text{ V}; V_{DS} = 28\text{ V}$	-	-	5	μA
I_{DSX}	drain cut-off current	$V_{GS} = V_{GS(th)} + 9\text{ V}; V_{DS} = 10\text{ V}$	9	-	-	A
I_{GSS}	gate leakage current	$V_{GS} = \pm 15\text{ V}; V_{DS} = 0\text{ V}$	-	-	11	nA
g_{fs}	transfer conductance	$V_{DS} = 10\text{ V}; I_D = 2.5\text{ A}$	-	3	-	S
$R_{DS(on)}$	drain-source on-state resistance	$V_{GS} = V_{GS(th)} + 9\text{ V}; I_D = 2.5\text{ A}$	-	0.3	-	Ω
C_{rs}	feedback capacitance	$V_{GS} = 0\text{ V}; V_{DS} = 28\text{ V}; f = 1\text{ MHz}$	-	1.7	-	pF

7. Application information

Table 8. Application information

$V_{DS} = 26\text{ V}; T_h = 25\text{ °C}$ unless otherwise specified.

Symbol	Parameter	Conditions	Min	Typ	Max	Unit
Mode of operation: Two-tone CW (100 kHz tone spacing); $f = 2000\text{ MHz}; I_{Dq} = 450\text{ mA}$						
G_p	power gain	$P_{L(PEP)} = 30\text{ W}$	12.5	13.5	-	dB
RL_{in}	input return loss	$P_{L(PEP)} = 30\text{ W}$	-	-16	-11	dB
η_D	drain efficiency	$P_{L(PEP)} = 30\text{ W}$	32	35.0	-	%
IMD3	third order intermodulation distortion	$P_{L(PEP)} = 30\text{ W}$	-	-26	-23	dBc
		$P_{L(PEP)} < 10\text{ W}$	-	< -50	-	dBc
Mode of operation: one-tone CW; $f = 2000\text{ MHz}; I_{Dq} = 450\text{ mA}$						
G_p	power gain	$P_L = P_{L(1dB)} = 36\text{ W}$	-	12.5	-	dB
η_D	drain efficiency	$P_L = P_{L(1dB)} = 36\text{ W}$	-	43	-	%
Mode of operation: PHS; $f = 1900\text{ MHz}; I_{Dq} = 1\text{ A}$						
G_p	power gain	$P_{L(AV)} = 9\text{ W}$	-	16	-	dB
η_D	drain efficiency	$P_{L(AV)} = 9\text{ W}$	-	20	-	%

7.1 Ruggedness in class-AB operation

The BLF3G21-30 is capable of withstanding a load mismatch corresponding to VSWR = 10 : 1 through all phases under the following conditions: $V_{DS} = 26\text{ V}$; $f = 2200\text{ MHz}$ at rated load power.

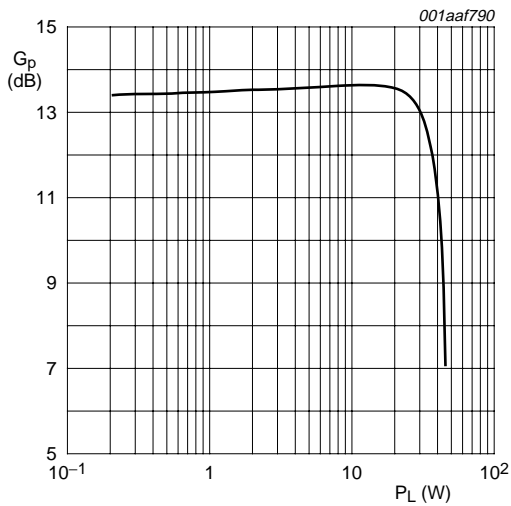

$V_{DS} = 26\text{ V}$; $I_{Dq} = 450\text{ mA}$; $T_h = 25\text{ }^\circ\text{C}$; $f = 2000\text{ MHz}$

Fig. 1. Power gain as function of CW load power; typical values

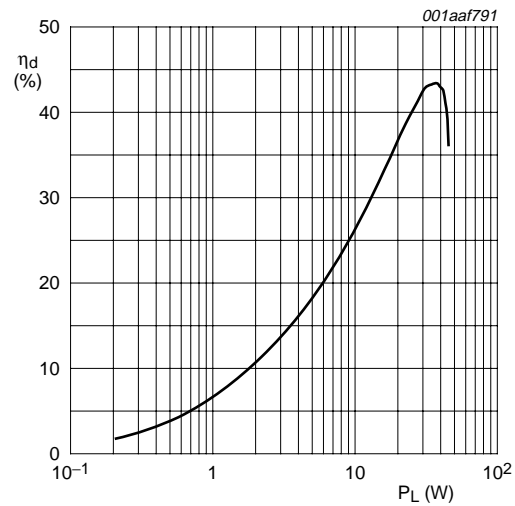

$V_{DS} = 26\text{ V}$; $I_{Dq} = 450\text{ mA}$; $T_h = 25\text{ }^\circ\text{C}$; $f = 2000\text{ MHz}$

Fig. 2. Drain efficiency as function of CW load power; typical values

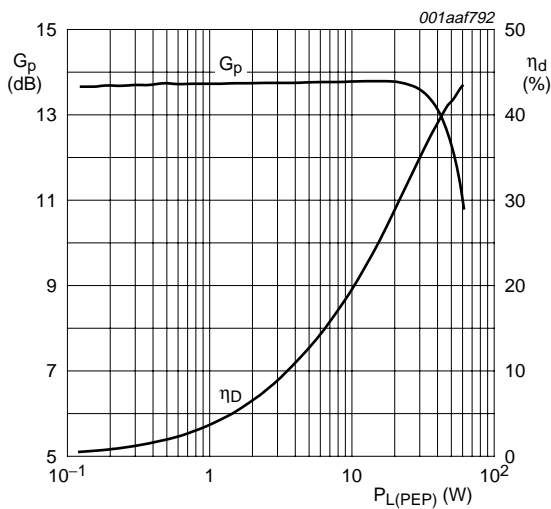

$V_{DS} = 26\text{ V}$; $I_{Dq} = 450\text{ mA}$; $T_h \leq 25\text{ }^\circ\text{C}$;
 $f_1 = 2000\text{ MHz}$; $f_2 = 2000.1\text{ MHz}$

Fig. 3. Two-tone power gain and drain efficiency as functions of peak envelope load power; typical values

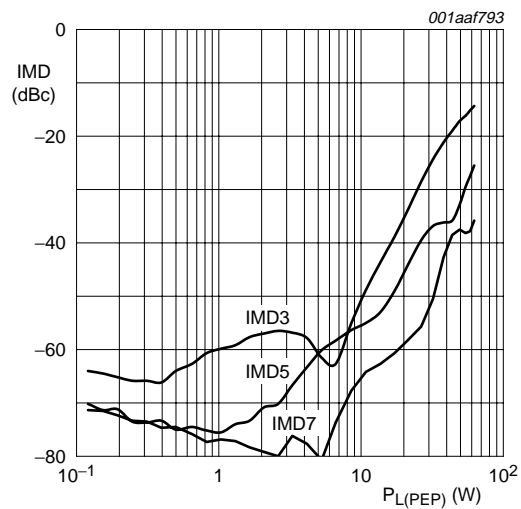

$V_{DS} = 26\text{ V}$; $I_{Dq} = 450\text{ mA}$; $T_h \leq 25\text{ }^\circ\text{C}$;
 $f_1 = 2000\text{ MHz}$; $f_2 = 2000.1\text{ MHz}$

Fig. 4. Two-tone intermodulation distortion as function of peak envelope load power; typical values

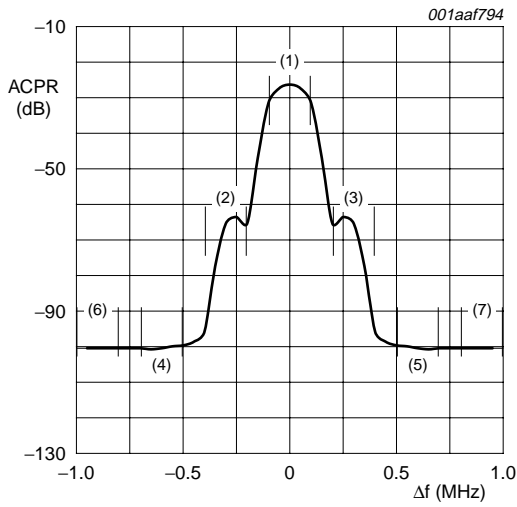

(1) 192 kHz channel bandwidth
 (2) $-ACPR_{300}$ at 192 kHz bandwidth
 (3) $+ACPR_{300}$ at 192 kHz bandwidth
 (4) $-ACPR_{600}$ at 192 kHz bandwidth
 (5) $+ACPR_{600}$ at 192 kHz bandwidth
 (6) $-ACPR_{900}$ at 192 kHz bandwidth
 (7) $+ACPR_{900}$ at 192 kHz bandwidth
 $V_{DS} = 26\text{ V}$; $I_{DQ} = 1000\text{ mA}$; $T_h \leq 25\text{ }^\circ\text{C}$;
 $f_c = 1900\text{ MHz}$; $P_{L(AV)} = 9\text{ W}$

Fig 5. ACPR performance under PHS conditions, measured in application board

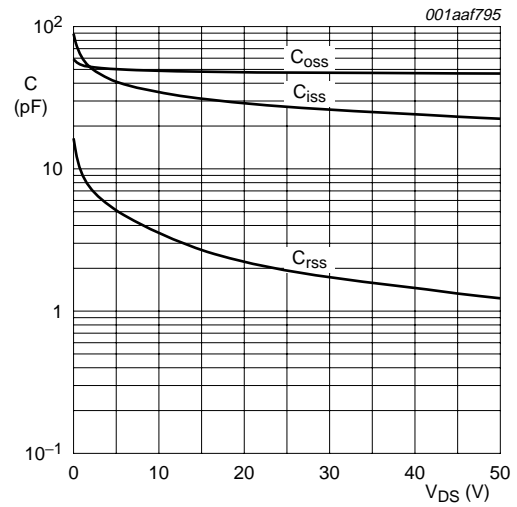
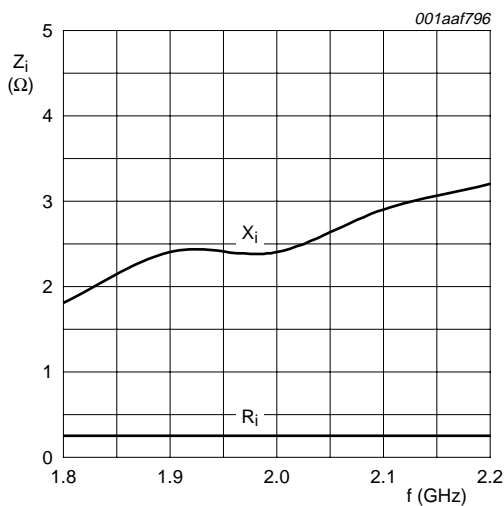
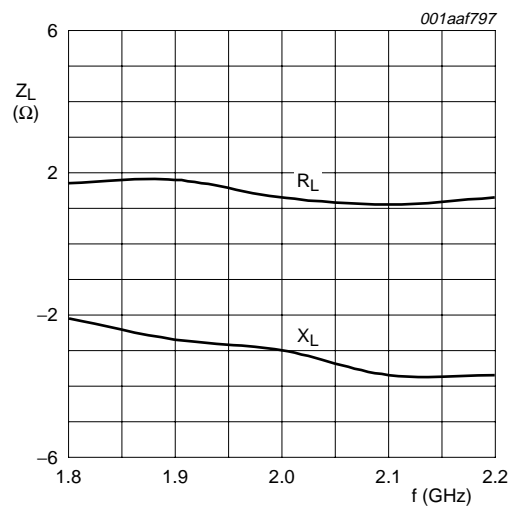

Fig 6. C_{iss} , C_{rss} and C_{oss} as functions of drain supply voltage; typical values



$V_{DS} = 26\text{ V}$; $I_{DQ} = 450\text{ mA}$; $P_L = 45\text{ W}$; $T_h \leq 25\text{ }^\circ\text{C}$

Fig 7. Input impedance as function of frequency (series components); typical values



$V_{DS} = 26\text{ V}$; $I_{DQ} = 450\text{ mA}$; $P_L = 45\text{ W}$; $T_h \leq 25\text{ }^\circ\text{C}$

Fig 8. Load impedance as function of frequency (series components); typical values

8. Test information

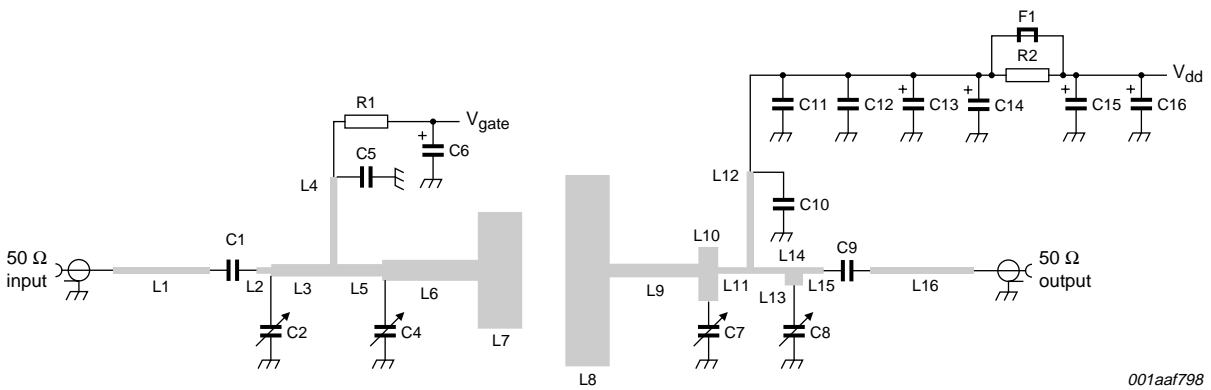
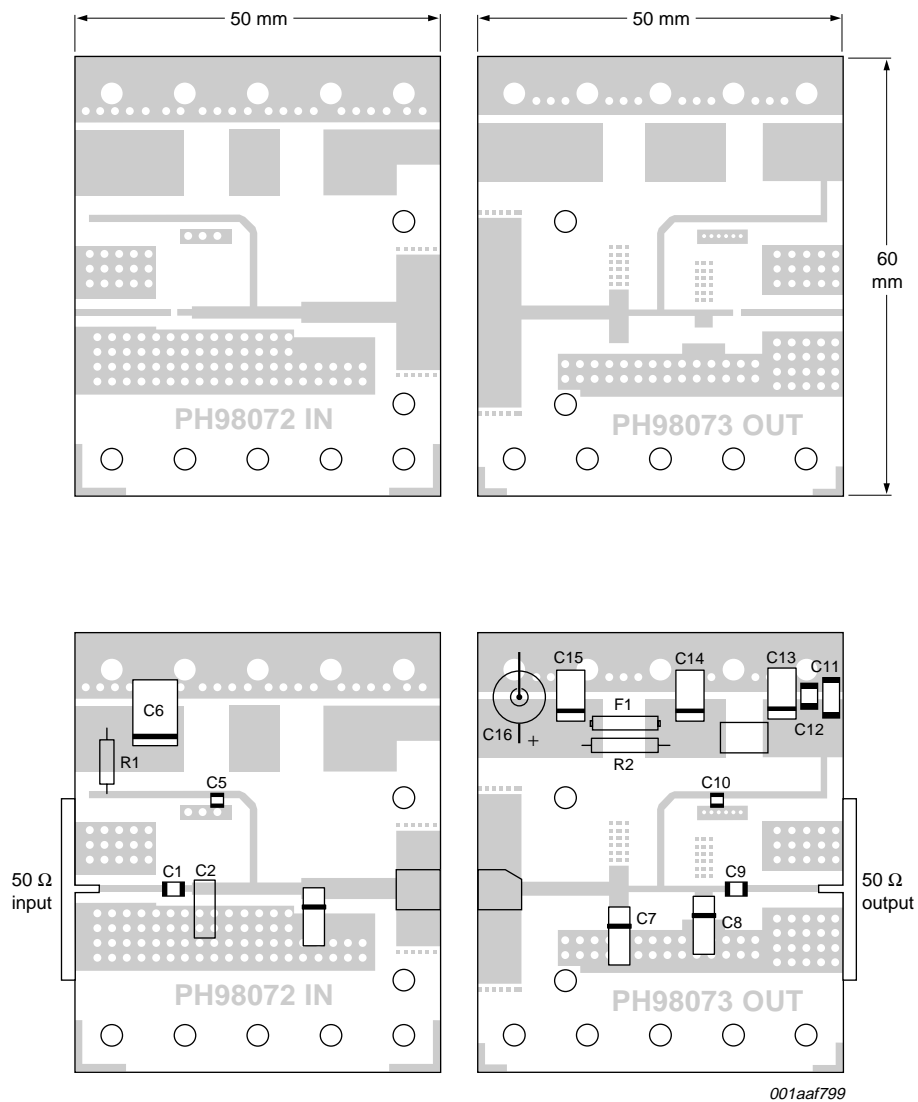

Fig 9. Class-AB test circuit for 2 GHz



The components are situated on one side of the copper-clad Printed-Circuit Board (PCB) with Teflon dielectric ($\epsilon_r = 6.15$); thickness = 0.64 mm. The other side is unetched and serves as a ground plane.

See [Table 9](#) for a list of components.

Fig 10. Component layout for 2 GHz class-AB test circuit

Table 9. List of components (see Figure 9 and Figure 10)

Component	Description	Value	Dimensions	Catalogue No.
C1, C9	multilayer ceramic chip capacitor	[2] 11 pF		
C2, C4, C7, C8	Tekelec variable capacitor; type 37271	0.6 pF to 4.5 pF		
C5, C10	multilayer ceramic chip capacitor	[1] 12 pF		
C6, C13, C14, C15	tantalum SMD capacitor	4.5 μ F; 50 V		
C11	multilayer ceramic chip capacitor	[2] 1 nF		
C12	multilayer ceramic chip capacitor	100 nF		2222 581 16641
C16	electrolytic capacitor	100 μ F; 63 V		2222 037 58101
F1	ferrite SMD bead		8DS3/3/8/9-4S2	4330 030 36301
L1	stripline	[3] 50 Ω	13 mm \times 0.9 mm	
L2	stripline	[3] 50 Ω	2 mm \times 0.9 mm	
L3	stripline	[3] 34.3 Ω	15 mm \times 1.7 mm	
L4, L12	stripline	[3] 50 Ω	37 mm \times 0.9 mm	
L5	stripline	[3] 34.3 Ω	6 mm \times 1.7 mm	
L6	stripline	[3] 23.6 Ω	13 mm \times 2.9 mm	
L7	stripline	[3] 5.6 Ω	6 mm \times 15.8 mm	
L8	stripline	[3] 3.5 Ω	6 mm \times 26 mm	
L9	stripline	[3] 31.9 Ω	12 mm \times 1.9 mm	
L10	stripline	[3] 24.9 Ω	7.4 mm \times 2.7 mm	
L11	stripline	[3] 50 Ω	3 mm \times 0.9 mm	
L13	stripline	[3] 50 Ω	4.15 mm \times 0.9 mm	
L14	stripline	[3] 26.3 Ω	2.5 mm \times 2.5 mm	
L15	stripline	[3] 50 Ω	2.8 mm \times 0.9 mm	
L16	stripline	[3] 50 Ω	14 mm \times 0.9 mm	
R1, R2	metal film resistor	10 Ω ; 0.6 W		2322 156 11009

[1] American Technical Ceramics type 100B or capacitor of same quality

[2] American Technical Ceramics type 100A or capacitor of same quality

[3] The striplines are on a double copper-clad Printed-Circuit Board (PCB) with Teflon dielectric ($\epsilon_r = 6.15$); thickness = 0.64 mm

9. Package outline

Flanged LDMOST ceramic package; 2 mounting holes; 2 leads

SOT467C

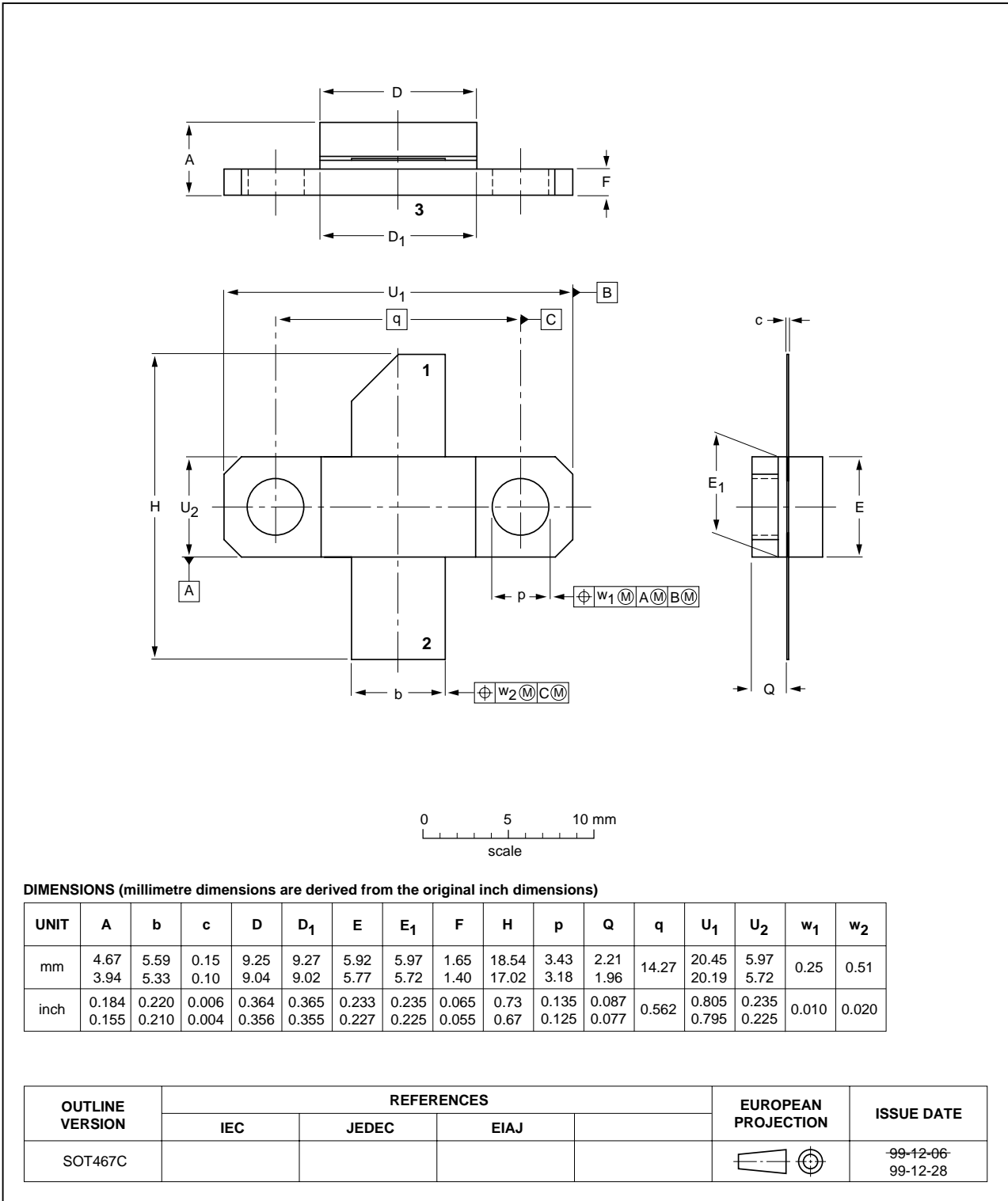

Fig 11. Package outline SOT467C

10. Abbreviations

Table 10. Abbreviations

Acronym	Description
CDMA	Code Division Multiple Access
EDGE	Enhanced Data rates for the GSM Evolution
GSM	Global System for Mobile communications
HF	High Frequency
LDMOS	Laterally Diffused Metal Oxide Semiconductor
LDMOST	Laterally Diffused Metal-Oxide Semiconductor Transistor
PHS	Personal HandyPhone System
RF	Radio Frequency
SMD	Surface-Mount Device
UHF	Ultra High Frequency
VSWR	Voltage Standing-Wave Ratio
W-CDMA	Wideband Code Division Multiple Access

11. Revision history

Table 11. Revision history

Document ID	Release date	Data sheet status	Change notice	Supersedes
BLF3G21-30_1	20070214	Product data sheet	-	-

12. Legal information

12.1 Data sheet status

Document status ^{[1][2]}	Product status ^[3]	Definition
Objective [short] data sheet	Development	This document contains data from the objective specification for product development.
Preliminary [short] data sheet	Qualification	This document contains data from the preliminary specification.
Product [short] data sheet	Production	This document contains the product specification.

[1] Please consult the most recently issued document before initiating or completing a design.

[2] The term 'short data sheet' is explained in section "Definitions".

[3] The product status of device(s) described in this document may have changed since this document was published and may differ in case of multiple devices. The latest product status information is available on the Internet at URL <http://www.nxp.com>.

12.2 Definitions

Draft — The document is a draft version only. The content is still under internal review and subject to formal approval, which may result in modifications or additions. NXP Semiconductors does not give any representations or warranties as to the accuracy or completeness of information included herein and shall have no liability for the consequences of use of such information.

Short data sheet — A short data sheet is an extract from a full data sheet with the same product type number(s) and title. A short data sheet is intended for quick reference only and should not be relied upon to contain detailed and full information. For detailed and full information see the relevant full data sheet, which is available on request via the local NXP Semiconductors sales office. In case of any inconsistency or conflict with the short data sheet, the full data sheet shall prevail.

12.3 Disclaimers

General — Information in this document is believed to be accurate and reliable. However, NXP Semiconductors does not give any representations or warranties, expressed or implied, as to the accuracy or completeness of such information and shall have no liability for the consequences of use of such information.

Right to make changes — NXP Semiconductors reserves the right to make changes to information published in this document, including without limitation specifications and product descriptions, at any time and without notice. This document supersedes and replaces all information supplied prior to the publication hereof.

Suitability for use — NXP Semiconductors products are not designed, authorized or warranted to be suitable for use in medical, military, aircraft, space or life support equipment, nor in applications where failure or

malfunction of a NXP Semiconductors product can reasonably be expected to result in personal injury, death or severe property or environmental damage. NXP Semiconductors accepts no liability for inclusion and/or use of NXP Semiconductors products in such equipment or applications and therefore such inclusion and/or use is at the customer's own risk.

Applications — Applications that are described herein for any of these products are for illustrative purposes only. NXP Semiconductors makes no representation or warranty that such applications will be suitable for the specified use without further testing or modification.

Limiting values — Stress above one or more limiting values (as defined in the Absolute Maximum Ratings System of IEC 60134) may cause permanent damage to the device. Limiting values are stress ratings only and operation of the device at these or any other conditions above those given in the Characteristics sections of this document is not implied. Exposure to limiting values for extended periods may affect device reliability.

Terms and conditions of sale — NXP Semiconductors products are sold subject to the general terms and conditions of commercial sale, as published at <http://www.nxp.com/profile/terms>, including those pertaining to warranty, intellectual property rights infringement and limitation of liability, unless explicitly otherwise agreed to in writing by NXP Semiconductors. In case of any inconsistency or conflict between information in this document and such terms and conditions, the latter will prevail.

No offer to sell or license — Nothing in this document may be interpreted or construed as an offer to sell products that is open for acceptance or the grant, conveyance or implication of any license under any copyrights, patents or other industrial or intellectual property rights.

12.4 Trademarks

Notice: All referenced brands, product names, service names and trademarks are the property of their respective owners.

13. Contact information

For additional information, please visit: <http://www.nxp.com>

For sales office addresses, send an email to: salesaddresses@nxp.com

14. Contents

1 Product profile 1

1.1 General description 1

1.2 Features 1

1.3 Applications 2

2 Pinning information 2

3 Ordering information 2

4 Limiting values 2

5 Thermal characteristics 3

6 Characteristics 3

7 Application information 3

7.1 Ruggedness in class-AB operation 4

8 Test information 6

9 Package outline 9

10 Abbreviations 10

11 Revision history 10

12 Legal information 11

12.1 Data sheet status 11

12.2 Definitions 11

12.3 Disclaimers 11

12.4 Trademarks 11

13 Contact information 11

14 Contents 12

Please be aware that important notices concerning this document and the product(s) described herein, have been included in section 'Legal information'.



© NXP B.V. 2007.

All rights reserved.

For more information, please visit: <http://www.nxp.com>

For sales office addresses, please send an email to: salesaddresses@nxp.com

Date of release: 14 February 2007

Document identifier: BLF3G21-30_1