

SPiRiT HE AAC Encoder

High Efficiency Advanced Audio Coding technology (also known as AAC+) was standardized as Part 3 of the MPEG-4 international standard. The Advanced Audio Coding in MPEG-4 Part 3 was enhanced relative to specifications of MPEG-2 Part 7 (AAC LC and Main profiles), in order to provide better sound quality in terms of the bit rate used for encoding. HE AAC v1 (or AAC+) technology combines Advanced Audio Coding (AAC) and Spectral Band Replication (SBR) algorithms.

SPiRiT HE AAC Encoder is fully compliant to the MPEG-4 Part 3 standard. It implements all HE AAC features for embedded platforms. SPiRiT HE AAC Encoder has high decoding performance, lowering the final system cost and saving more CPU power and memory space.

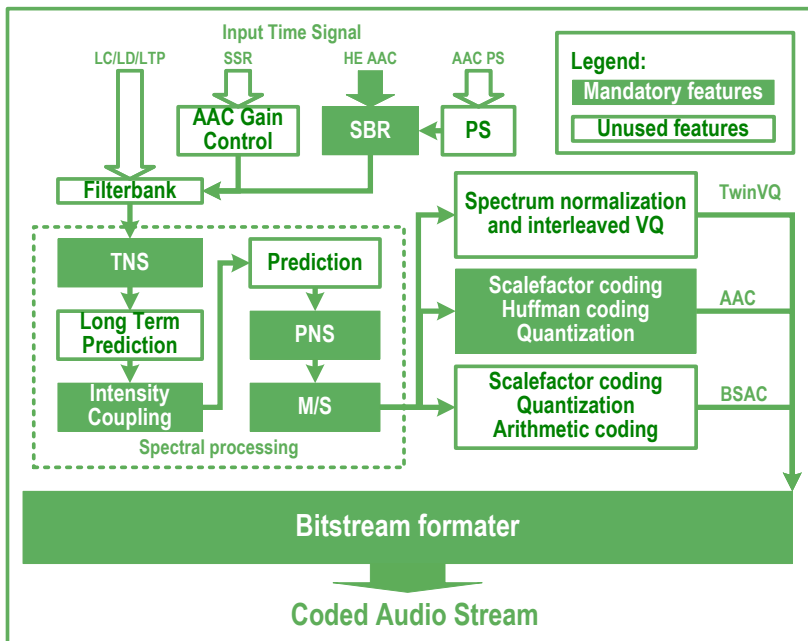

Benefits

- Highly optimized code ideal for resource constrained applications
- Easy integration and fast time to market
- Allows to save several hours of SoC battery life

Key Features

- Low CPU load
- Small memory footprint
- Simple API
- Fully compliant to the ISO MPEG standard

Applications

- Portable media players
- CD-rippers
- Set-top boxes
- Mobile phones
- Car electronics

Availability

- | | |
|-------------------|------|
| • TI C6xx | Now |
| • Tensilica HiFi2 | Now |
| • TI OMAP3 | Call |
| • BlackFin | Call |
| • ARM | Call |
| • MIPS | Call |
| • AudioDE | Call |

Features

- High optimization
- Quality assurance with ITU-R BS.1387 recommendation
- Support for HE AAC v1 (AAC+) and HE AAC v2 (eAAC+) coding tools
- Sampling rates from 8 to 96 kHz
- Tools: MS (Mid-side Stereo), TNS (Temporal Noise shaping), PNS (Perceptual Noise Substitution)
- Support for LC profile
- Simple API

Specifications

SPiRiT HE AAC encoder produces bitstream fully compliant to the MPEG-4 Part 3 (ISO/IEC 14496-3) international standard. Coding quality is assured with objective quality metrics according to the ITU-R BS.1387 recommendation. TI C6xx version is eXpressDSP compliant. Code is reentrant, supports multithreading and dynamic memory allocation. At the same time allows direct (non-eXpressDSP) interface to enable static memory allocation. The encoder supports Low Complexity (LC) profile, and optional Spectral Band Replication (SBR) and Parametric Stereo (PS) coding tools.

Resource Requirements

PLATFORM	Intel Pentium	Intel Pentium	TI C64x	Tensilica HiFi2
PROFILE	HE AAC v1	HE AAC v2	HE AAC v1	HE AAC v2
Peak MIPS*	150	140	18	40
Average MIPS**	90	80	17	36
Program Memory, KB	43	43	74	80
Constant Memory, KB	28	28	20	20
Persistent Memory, KB per stereo	33	33	33	25
Scratch, KB	13	13	13.5	50
Stack, KB	1	1	1	2

* Average MIPS are specified for 44.1 KHz at 112 kbps
 MIPS are measured using simulator with 0-WS. For C6x platform, MIPS figures correspond to MCPS

CONTACTS

General: 1-408-540-6033
www.spiritdsp.com

Russia: 7-495-661-21-78
 France: 33-623-021-563
 Israel: 972-3-736-9763
 Italy: 39-02-6680-2557

Germany: 49-641-48-08300
 USA: 1-888-374-4410
 Canada: 1-888-374-4410
 Japan: +81-3-6361-8080

Taiwan: 886-2-2888-1010, 886-2-2696-0055
 Korea: 82-70-7780-9910, 82-2-33473-5080
 China: 86-21-63502288-820
 Singapore: 65-6744- 9789