

## SPIRIT AAC LC Encoder

MPEG-2/MPEG-4 Low Complexity Audio Codec (AAC-LC) is the simplest and most widely used and supported AAC profile. Despite its low computational complexity, AAC LC provides good sound quality at as low as 64 Kbps bitrate. Codec supports various sampling rates and bitrates. These features have made AAC LC codec a perfect solution for a wide range of application.

SPiRiT AAC LC Encoder is a highly efficient encoder solution, targeted to various embedded appliances. The encoder is optimized to achieve the best performance and save system resources.

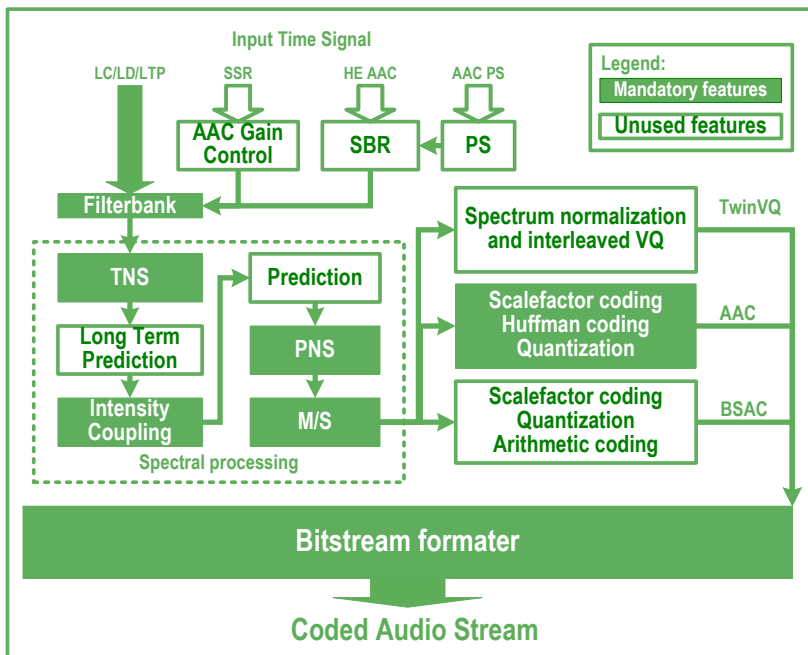

## Features

- Fully compliant to the ISO MPEG-2/MPEG-4 Low Complexity codec standard
- Low CPU usage and memory footprint
- Sampling rates from 8 to 96 kHz (compared to 48 kHz for MP3)
- Bit rates from 8 Kbps to 576 Kbps for mono and from 16 Kbps to 1152 Kbps for stereo signal
- Support for mono and stereo channels
- TI C6xx version is XDAIS compliant (including parent/child support for paging tables)
- Code is reentrant, supports multithreading and dynamic memory allocation

## Specifications

- Coding tools supported: joint stereo, block switching
- TNS, PNS can be switched off/on
- Encoder includes Mid/Side Coding Tool used to reduce channel redundancy in stereo signals, thereby improving the compression ratio without significant loss of perceived quality
- Support for 1 or 2 channels
- All valid AAC bitrates are supported
- Fixed or variable bitrate encoding supported
- Encoder produces ADTS or raw bitstream

## Benefits

- Highly optimized code ideal for resource constrained applications
- Easy integration and fast time to market
- Allows to save several hours of SoC battery life

## Key Features

- Low CPU usage
- Small memory footprint
- Simple API
- Fully compliant to the ISO MPEG standard

## Applications

- Mobile phones
- Set-top boxes
- Communicators
- Audio streaming/Digital radio
- Internet appliances
- Portable media players
- Car electronics

## Availability

- TI C6xx Now
- AudioDE Now
- TI OMAP3 Call
- ARM Call
- MIPS Call

## Resource Requirements

PLATFORM	TI C64xx	ARM9E
Peak MIPS	13	22
Average MIPS	10	15
Program Memory, KB	50	80
Const Memory, KB	17	25
Persistent Memory, KB per stereo	9	40
Scratch, KB	10	32
Stack, KB	2	12

*MIPS are specified for 48 kHz at 320 kbps*

*MIPS are measured using simulator with 0-WS*

*MIPS figures are specified for PNS and TNS coding tools status on*

### CONTACTS

General: 1-408-540-6033  
[www.spiritdsp.com](http://www.spiritdsp.com)

Russia: 7-495-661-21-78

France: 33-623-021-563

Israel: 972-3-736-9763

Italy: 39-02-6680-2557

Germany: 49-641-48-08300

USA: 1-888-374-4410

Canada: 1-888-374-4410

Japan: +81-3-6361-8080

Taiwan: 886-2-2888-1010, 886-2-2696-0055

Korea: 82-70-7780-9910, 82-2-33473-5080

China: 86-21-63502288-820

Singapore: 65-6744- 9789