



**Applied  
Motion  
Products**

## **BLuDC** Series Servo Drives

The BLuDC Series Servo Drives provide compact, reliable solutions for a wide range of motion applications in a variety of industries. BLuDC Series Servo Drives are designed to offer excellent performance coupled with hardware and software features that make them easy to integrate, use, and maintain.

The BLuDC hardware features a powerful digital signal processor (DSP) coupled with an efficient MOSFET PWM amplifier. When combined with the BLuDC's sophisticated yet easy to tune current, velocity, and position loops, the result is a system capable of extremely high performance and the assurance of success in even the most demanding of applications.

### **Features:**

- All-digital design means no trimpots or dip switches: all drive settings configured through software
- Selectable commutation (sinusoidal or trapezoidal) for a wide variety of motors including brushless, brushed, and linear servo motors
- Multiple control options
- Compact size
- Easy-to-use and set up through Quick Tuner application software
- Reliable: optically isolated I/O, digital protection circuits built-in, surface mount technology



- RS-232 and RS-485 comm ports for programming and serial communications

### **BLuDC9**

- 9 amps cont, 18 amps peak
- 400 Watts with 48 Vdc supply
- Packaged in an enclosure

### **BLuDC4**

- 4.5 amps cont, 13.5 amps peak
- 200 Watts with 48 Vdc supply
- Exposed printed circuit board

### **Control Options:**

- Analog Command Signal (+/- 10V)
- Pulse & Direction
- CW & CCW Pulse
- Encoder Following
- Host Serial Commands via RS-232/485
- Integrated motion control with either Si Programmer or Q Programmer application software

# Drive Models

(Available with enclosure, BLuDC9, and without enclosure, BLuDC4)



## BLuDC9-S, BLuDC4-S

Basic drive: analog, digital, and host serial command inputs

- Analog +/- 10V torque, velocity, and positioning modes
- Pulse & Direction with electronic gearing
- CW / CCW Pulse
- Encoder Following with electronic gearing
- Multi-axis Si programming when used with a SiNet Hub
- Host serial command execution of commands sent over serial connection from a host device (PC, PLC, HMI, etc.)



## BLuDC9-Si, BLuDC4-Si

Stand-alone program execution of programs created with the Si Programmer application software

- Intuitive, easy-to-use software with integrated servo tuning
- Graphical point-and-click format combines motion, I/O, logic, and operator interface (MMI-01) functionality in one program
- Easily integrates with external devices through discrete I/O
- Excellent for simple motion sequencing



## BLuDC9-Q, BLuDC4-Q

Stand-alone program execution with Q Programmer application software as well as host serial command functionality

- Register manipulation
- Conditional processing
- Math functions
- Multi-tasking
- I/O Handling
- Flexible Programming
- Sophisticated motion control and motor drive in one package

## Features Summary

Drive Model	BLuDC-S	BLuDC-Si	BLuDC-Q
SiNet Hub compatible	•	•	•
Command Inputs			
<i>Analog +/- 10V</i>	•		•
<i>Pulse &amp; Direction</i>	•		•
<i>CW / CCW Pulse</i>	•		•
<i>Encoder Following</i>	•		•
<i>Host Serial Command Execution</i>	•	•	•
Si Indexer		•	
Q Programming			•
Logic Input Functions			
<i>Alarm Reset</i>	•		•
<i>End-of-travel Limit Switches</i>	•	•	•
<i>Servo Enable</i>	•		•
Logic Output Functions			
<i>Alarm</i>	•	•	•
<i>Brake</i>	•	•	•
<i>In-Position / Motion Output</i>	•	•	•
Digital Inputs	7 (15 with -SE)	15	7 (15 with -QE)
Digital Outputs	3 (7 with -SE)	7	3 (7 with -QE)
Analog Inputs	2	0	2

# Details

## S and Q Connections (shown on BLuDC9 hardware)

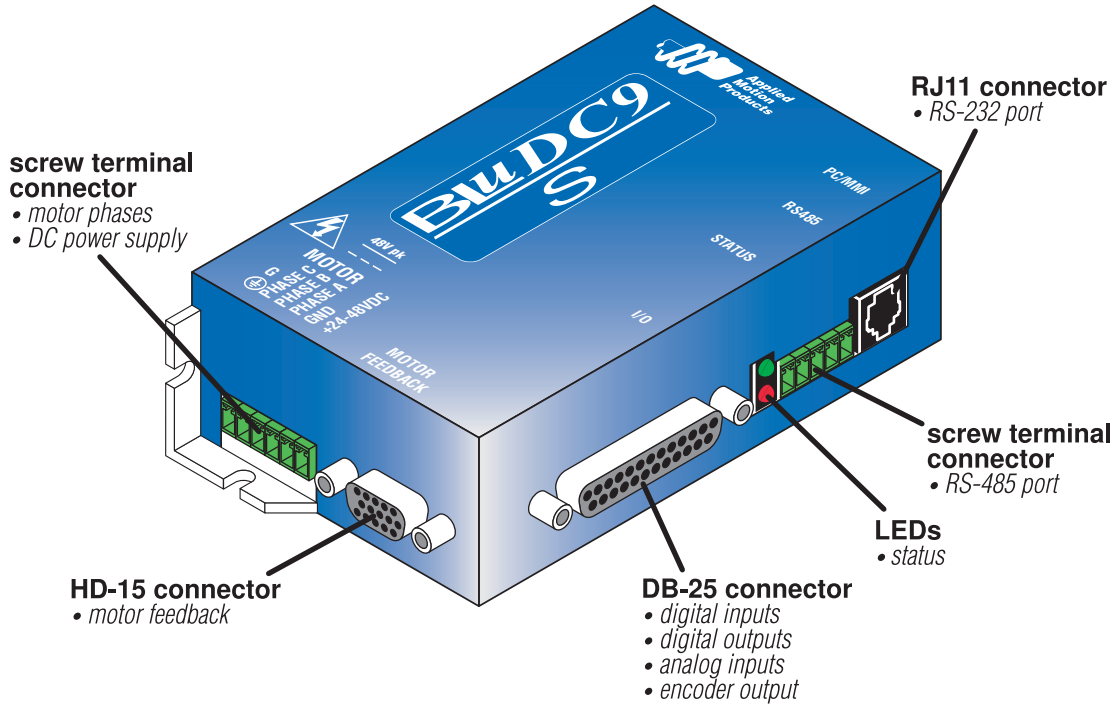

## Si, SE, and QE Connections (shown on BLuDC4 hardware)

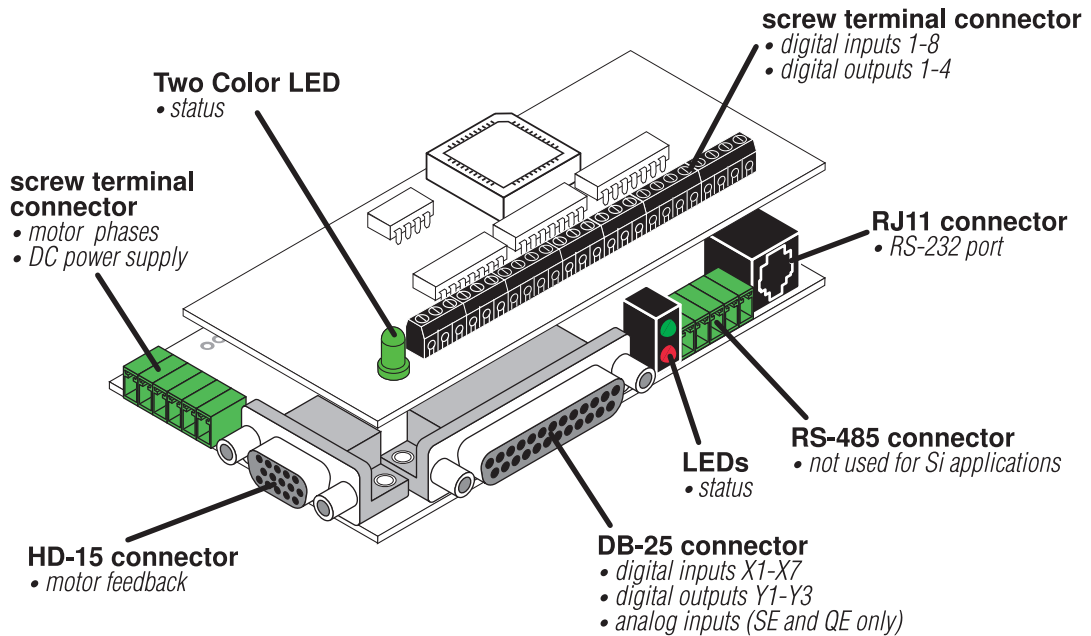

# Specifications

## Amplifier Section

AMPLIFIER TYPE .....	3-phase sinusoidally commutated with MOSFET power devices
CURRENT CONTROL .....	4 quadrant "DQ" method with PWM at 16 kHz
OUTPUT CURRENT .....	BLuDC9                    9.0 A continuous / 18.0 A peak BLuDC4                    4.5 A continuous / 13.5 A peak
DC INPUT VOLTAGE .....	24 - 48 VDC (18 VDC minimum, 53 VDC maximum)
REGENERATION .....	Requires external regen clamp board: RC-010 or RC-050.
CIRCUIT PROTECTION.....	Over-current / Short circuit, Over temperature, Over voltage, Under voltage, Encoder signal failure, Hall signal failure
POSITION FEEDBACK.....	A/B quadrature incremental encoder, 200 - 128,000 counts/rev (50 - 32,000 lines), 2 MHz maximum frequency.
POSITION RESOLUTION.....	Set via software to match incremental encoder resolution.
MAXIMUM MOTOR SPEED.....	8000 RPM, motor and load dependent.

## Controller Section

MOTION UPDATE .....	16 kHz
SERVO UPDATE .....	4 kHz
SERIAL COMMUNICATION.....	RS-232 programming and control port. Green and Red LED's for indicating receive & transmit activity. S & Q drives also can be controlled via RS-422/485 port and are addressable for multi-axis control via this port. Both ports (RS-232 & RS-422/485) selectable baud: 9600, 19200, 38400, 57600, 115200.
STATUS INDICATORS.....	Green and Red LED's indicate communication activity over serial ports, drive status, and drive alarm codes (faults).
DIGITAL INPUTS & OUTPUTS ...	All optically isolated 5-24 V logic; 2 high speed, 5 V logic inputs for Step (Pulse) & Direction and Encoder Following control.
ANALOG INPUT.....	S & Q drives only: configurable as single-ended or differential +/- 10V, +/- 5V, 0-10V, 0-5V. Can be used as one differential input or two single-ended inputs. 12-bit resolution (including sign).
S & Q PARAMETER RANGES....	Distance: 1 - 2,147,483,647 CW or CCW, relative or absolute positioning in encoder counts. Speed: 0.0042 - 133 rev/sec

Acceleration: 0.167 - 5000 rev/sec/sec  
 Deceleration: 0.167 - 5000 rev/sec/sec  
 Time Delays: 0.01 - 320 seconds  
 Si PARAMETER RANGES ..... Distance: 1 - 16,000,000 CW or CCW, absolute position +/- 2 billion.  
 Speed: 0.25 - 100 rev/sec  
 Acceleration: 1 - 3000 rev/sec/sec  
 Deceleration: 1 - 3000 rev/sec/sec  
 Time Delays: 0.01 - 300 seconds  
 Output Pulse Widths: 2 - 500 milliseconds  
 Iterations per loop: 1 - 65,535  
 Nested loops: 50 maximum  
 Subroutine call: 5 deep maximum

## Physical

WEIGHT ..... BLuDC4-S, Q: 3.1 oz (87 g)  
 BLuDC4-Si, SE, QE: 5.0 oz (140 g)  
 BLuDC9: 10 oz (280 g)  
 AMBIENT TEMPERATURE ..... 0 - 40° C  
 HUMIDITY ..... Maximum of 90% non-condensing  
 CONNECTORS ..... Screw terminal connectors for input power and motor, HD-15 for encoder/hall signals, DB25 for I/O. Si, SE, and QE have DB25P for additional I/O.

## I/O Detail

Drive Model	Total I/O	Dedicated Inputs*		General Purpose Inputs	Dedicated Outputs**		General Purpose Outputs	Analog Inputs
BLuDC9-S BLuDC4-S	7/3	6	Limit Switches (2) Alarm Reset Servo Enable Jog CW, CCW (2)	1	3	Alarm Motion Brake	0	2 single-ended or 1 differential
BLuDC9-Q BLuDC4-Q	7/3	6	Limit Switches (2) Alarm Reset Servo Enable Jog CW, CCW (2)	1	3	Alarm Motion Brake	0	2 single-ended or 1 differential
BLuDC9-Si BLuDC4-Si	15/7	4	Limit Switches (2) Jog CW, CCW (2)	11	3	Alarm Motion Brake	4	0

\*Dedicated Inputs can be re-defined as General Purpose Inputs through software.

\*\*Dedicated Outputs can be re-defined as General Purpose Outputs through software.

NOTE: Expansion I/O can be added to S and Q drives making them SE and QE drives: 8 additional inputs and 4 additional outputs.

NOTE: The encoder's index (Z) channel if present can be used as an additional "home" input.

# Dimensions

## BLuDC9 (All models)

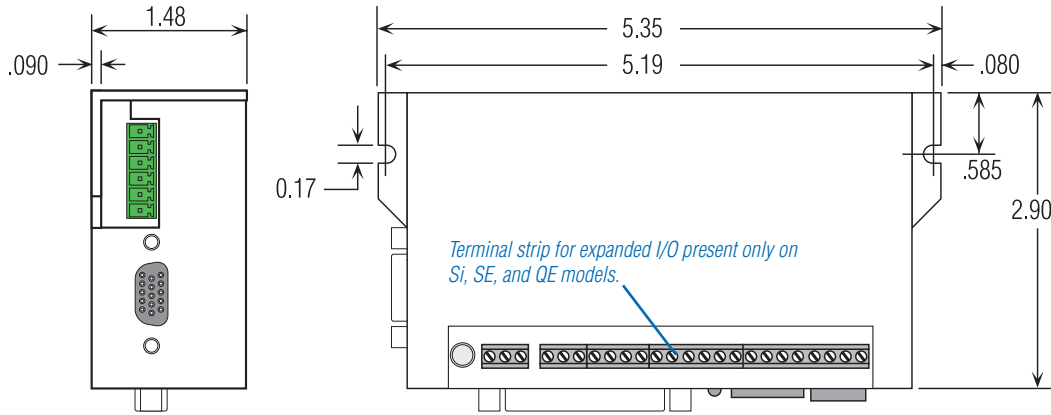

## BLuDC4 (S and Q models)

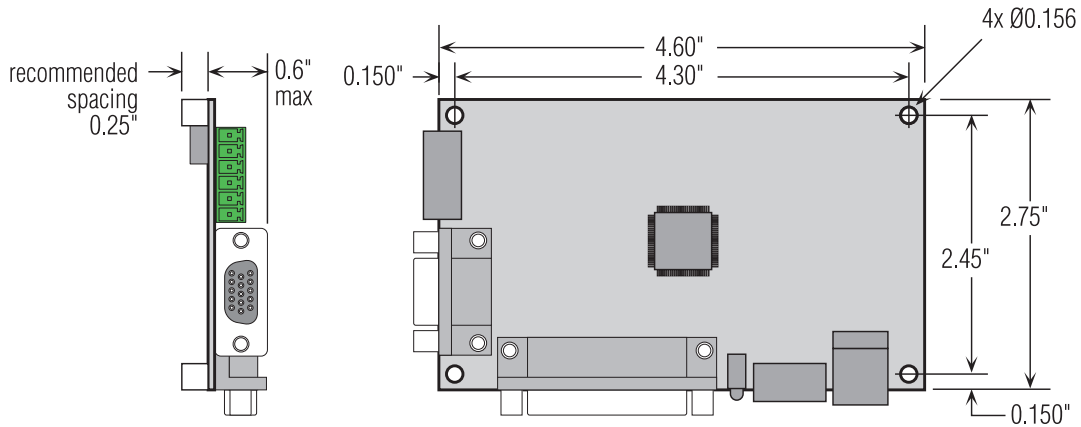

## BLuDC4 (Si, SE, and QE models)

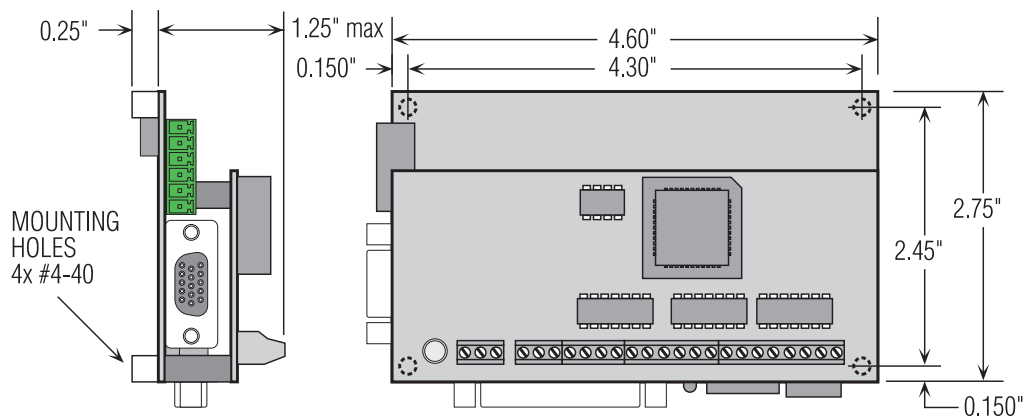

# Quick Tuner Configuration & Tuning Software

The BLuDC servo drives are supplied with the Quick Tuner software setup utility. In this one program the user can configure all the aspects of the drive. This includes setting the current, configuring inputs and outputs, and tuning the drive using the integrated oscilloscope with built-in trigger function.

The “Drive” tab allows the user to select the operating mode and enter options associated with the mode.

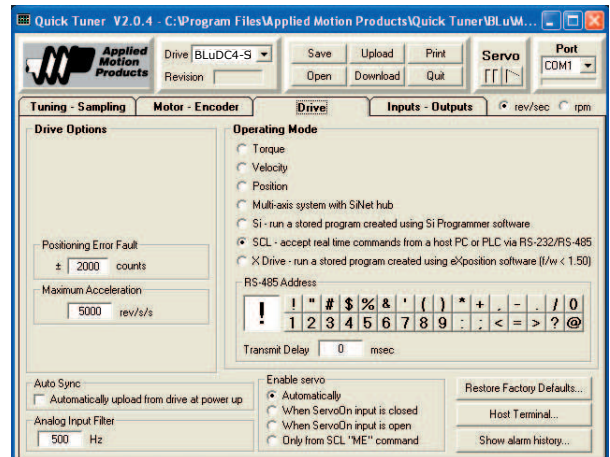

The “Inputs - Outputs” tab is used to configure the functionality of the drive. These functions include:

- Alarm Output
- Limit Switches (end-of-travel)
- Motion Output
- Brake Output

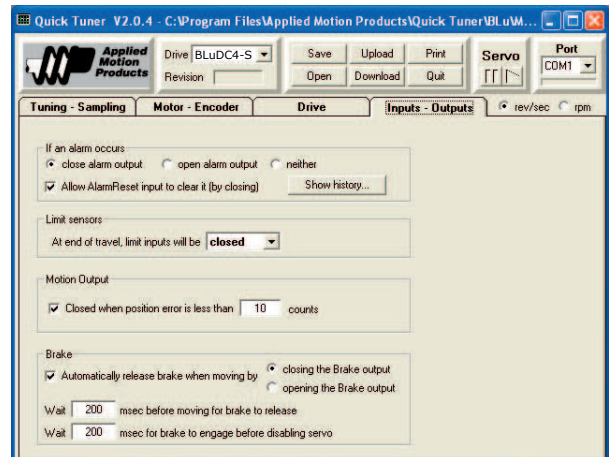

The “Tuning - Sampling” tab includes an oscilloscope function that can be used to display the effects of different servo loop gain values. A number of different drive parameters can be plotted, including:

- Target Speed
- Actual Speed
- Motor Current
- Position Error
- Supply Voltage

The oscilloscope function also features a trigger function and a monitor which continuously updates various parameter values.

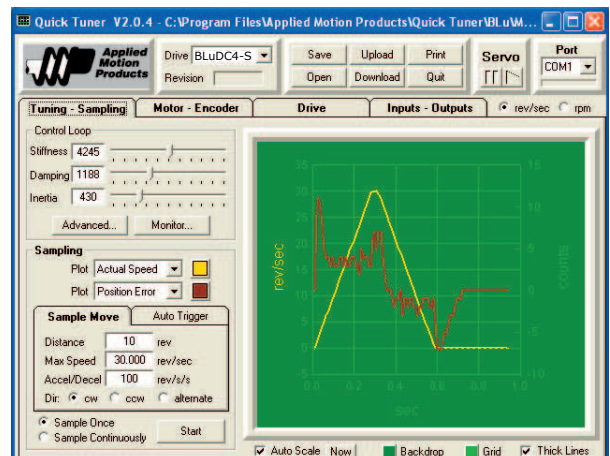

# Recommended Motors

## N Series Motors (NEMA flanges)

Motor Part No. w/o brake		N0030-103-A-000	N0050-103-A-000	N0100-103-A-000	N0100-103-B-000	N0200-104-B-000	N0400-105-B-000
Motor Part No. w/ brake		N0030-153-A-000	N0050-153-A-000	N0100-153-A-000	N0100-153-B-000	N0200-154-B-000	N0400-155-B-000
Mounting Flange	NEMA size	17	17	17	23	23	23
Rated Output	Watts	30	50	100	100	200	400
Power Supply	Volts	24	24	24	24	48	60
Rated Torque	in-lb (N-m)	0.85 (0.095)	1.4 (0.159)	2.81 (0.318)	2.81 (0.318)	5.66 (0.64)	11.2 (1.27)
Peak Torque	in-lb (N-m)	2.56 (0.29)	4.25 (0.48)	8.4 (0.95)	8.4 (0.95)	17.25 (1.91)	33.8 (3.82)
Rated Speed	RPM	3000	3000	3000	3000	3000	3000
Peak Speed	RPM	5000	5000	5000	5000	5000	4000
Rated Current	Amps RMS	2.8	3.9	7.4	7.7	6.4	8.2
Peak Current	Amps RMS	6.9	10.4	21.0	21.5	18.0	23.8
Torque Constant	in-lb/A (N-m/A)	0.36 (0.041)	0.40 (0.046)	0.40 (0.046)	0.39 (0.044)	0.93 (0.106)	1.41 (0.16)
Voltage Constant	V/RPM	0.0043	0.0048	0.0048	0.0046	0.0110	0.0168
Rotor Inertia	oz-in-sec <sup>2</sup> (g-cm <sup>2</sup> )	1.42x10 <sup>-4</sup> (10)	2.8x10 <sup>-4</sup> (20)	4.25x10 <sup>-4</sup> (30)	1.27x10 <sup>-3</sup> (90)	2.5x10 <sup>-3</sup> (180)	4.7x10 <sup>-3</sup> (340)

## M Series motors (Metric flanges)

Motor Part No. w/o brake		M0030-103-3-000	M0050-103-3-000	M0100-103-3-000	M0100-103-4-000	M0200-104-4-000	M0400-105-4-000
Motor Part No. w/ brake		M0030-153-3-000	M0050-153-3-000	M0100-153-3-000	M0100-153-4-000	M0200-154-4-000	M0400-155-4-000
Mounting Flange	mm	40	40	40	60	60	60
Rated Output	Watts	30	50	100	100	200	400
Power Supply	Volts	24	24	24	24	48	60
Rated Torque	in-lb (N-m)	0.85 (0.095)	1.4 (0.159)	2.81 (0.318)	2.81 (0.318)	5.66 (0.64)	11.2 (1.27)
Peak Torque	in-lb (N-m)	2.56 (0.29)	4.25 (0.48)	8.4 (0.95)	8.4 (0.95)	17.25 (1.91)	33.8 (3.82)
Rated Speed	RPM	3000	3000	3000	3000	3000	3000
Peak Speed	RPM	5000	5000	5000	5000	5000	4000
Rated Current	Amps RMS	2.8	3.9	7.4	7.7	6.4	8.2
Peak Current	Amps RMS	6.9	10.4	21.0	21.5	18.0	23.8
Torque Constant	in-lb/A (N-m/A)	0.36 (0.041)	0.40 (0.046)	0.40 (0.046)	0.39 (0.044)	0.93 (0.106)	1.41 (0.16)
Voltage Constant	V/RPM	0.0043	0.0048	0.0048	0.0046	0.0110	0.0168
Rotor Inertia	oz-in-sec <sup>2</sup> (g-cm <sup>2</sup> )	1.42x10 <sup>-4</sup> (10)	2.8x10 <sup>-4</sup> (20)	4.25x10 <sup>-4</sup> (30)	1.27x10 <sup>-3</sup> (90)	2.5x10 <sup>-3</sup> (180)	4.7x10 <sup>-3</sup> (340)

\* Consult factory for torque v. speed performance of the above recommended motors with BLuDC drives.

# Recommended Motors

## N Series Motors - NEMA 17

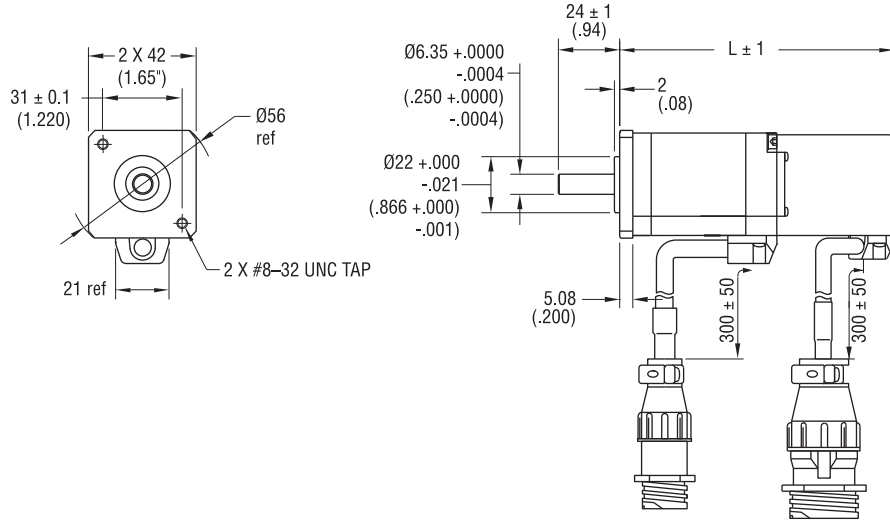

Motor Part No.	Dimension "L" mm (inch)
N0030-103-A-000	85.1 (3.35)
N0030-153-A-000	121 (4.76)
N0050-103-A-000	91.1 (3.59)
N0050-153-A-000	128 (5.03)
N0100-103-A-000	105 (4.13)
N0100-153-A-000	141 (5.55)

## M Series Motors - 40 mm

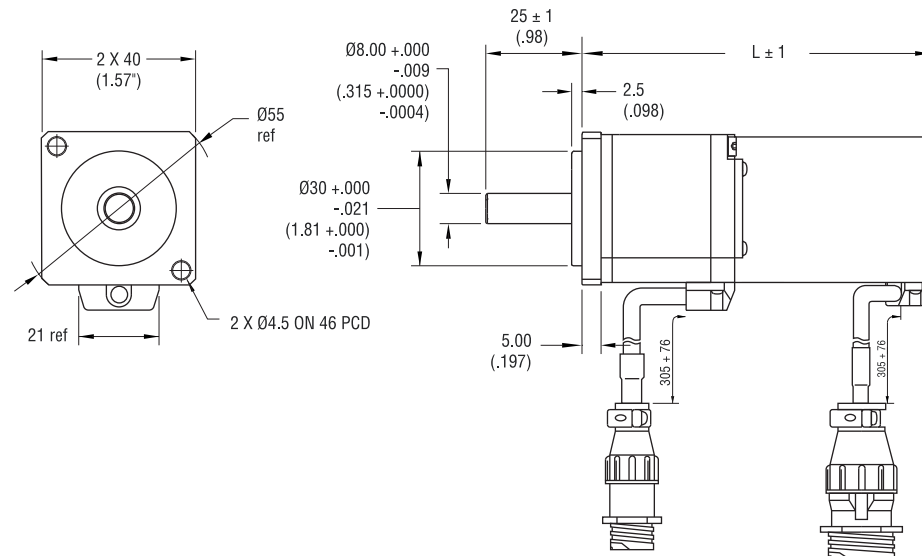

Motor Part No.	Dimension "L" mm (inch)
M0030-103-3-000	81 (3.18)
M0030-153-3-000	115.7 (4.55)
M0050-103-3-000	86.1 (3.38)
M0050-153-3-000	123 (4.84)
M0100-103-3-000	101 (3.97)
M0100-153-3-000	136 (5.35)

# Recommended Motors

## N Series Motors - NEMA 23

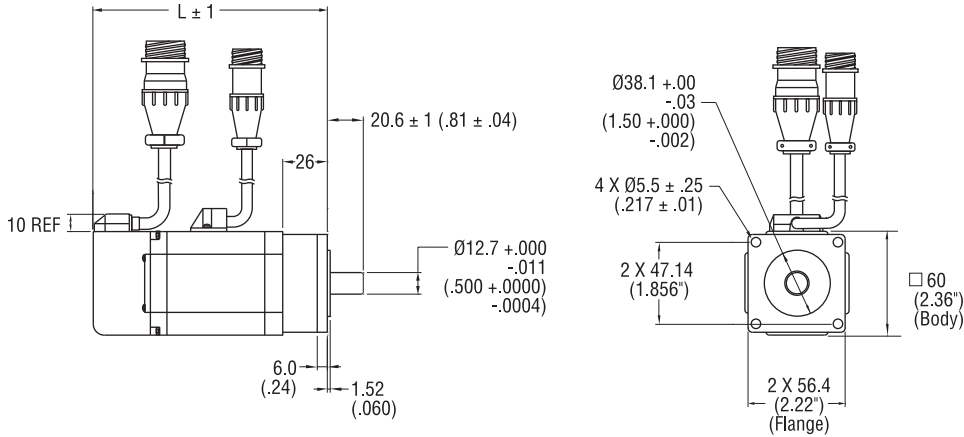

Motor Part No.	Dimension "L" mm (inch)
N0100-103-B-000	116 (4.56)
N0100-153-B-000	149 (5.87)
N0200-104-B-000	126 (4.96)
N0200-154-B-000	161 (6.33)
N0400-105-B-000	149 (5.86)
N0400-155-B-000	183 (7.2)

## M Series Motors - 60 mm

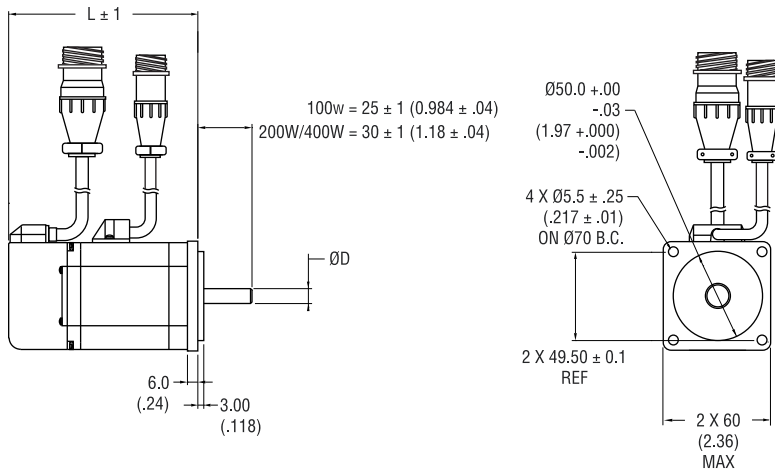

Motor Part No.	Dimension "L" mm (inch)	Dimension "D" mm (inch)
M0100-103-4-000	87 (3.42)	8 (0.314)
M0100-153-4-000	110 (4.33)	8 (0.314)
M0200-104-4-000	103 (4.05)	14 (0.551)
M0200-154-4-000	135 (5.31)	14 (0.551)
M0400-105-4-000	126 (4.96)	14 (0.551)
M0400-155-4-000	160 (6.3)	14 (0.551)

# Cables

The cables below are used for connecting an N or M series servo motor to a BLuDC servo drive. All cables are available in standard 4, 10, and 20 foot lengths, and custom lengths are available upon request.

## BLMTR-CA motor cables (for N and M series motors w/o brakes)

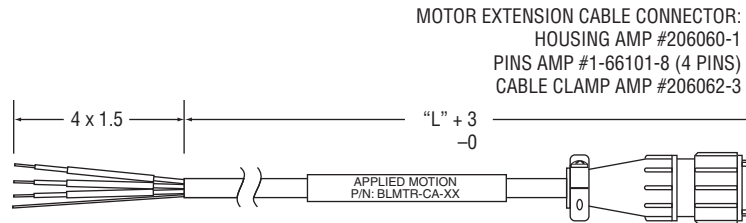

## BLMTR-BK-CA motor w/ brake cables (for N and M series motors w/ brakes)

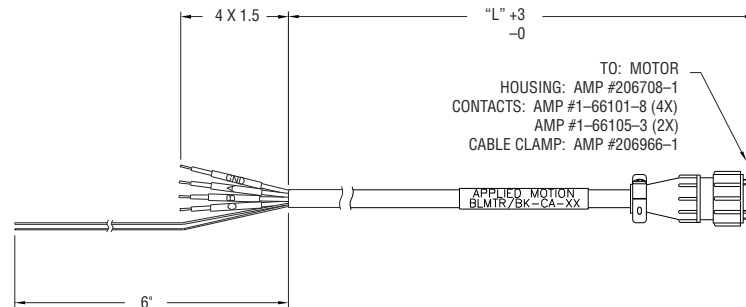

## BLuENC-CA feedback cables (for all N and M series motors)

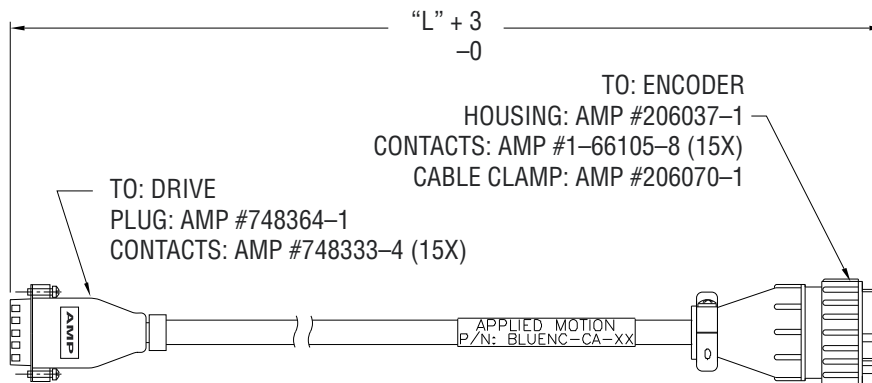

# Options

## I/O Expansion Board

Increases the number of digital inputs and outputs on BLuDC-S and Q drives from 7 inputs to 15 inputs, and from 3 outputs to 7 outputs. Drives can be ordered from the factory as BLuDC9-SE or QE and BLuDC4-SE or QE.

## Regeneration Clamp

As with most servo systems a clamp circuit is sometimes required to limit the power supply bus voltage when the motor is decelerating under load. The RC-050 regen clamp offers 50 Watts of continuous power dissipation (800 Watts peak).

## Hub 444 and SiNet Hub 8

The Hubs can be used to create multi-axis indexing systems. The SiNet Hub 8 can connect up to 8 axes to one program and the Hub 444 up to 4 axes. The Hub 444 also has 4 digital inputs and 4 digital outputs. Hubs are programmed with the SiNet Hub Programmer software.

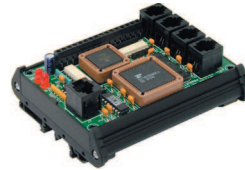

## MMI-01

For use with BLuDC-Si drives in applications where an operator interface is required for entering different values (motor speed, distance, position, cycle count, etc.) into an Si program. Available with a backlit display as well (MMI-02).



Applied Motion Products  
 404 Westridge Dr  
 Watsonville, CA 95076  
 tel (831) 761-6555  
 fax (831) 761-6544  
<http://www.applied-motion.com>