

REVISIONS				
SYM	ZONE	ECN, ERN NO.	DATE	APPRD.
A		PROPOSAL	OCT.25/04	K.L.
B		PROPOSAL	MAR.29/06	L.CHAN
C		PROPOSAL	DEC.29/09	L.CHAN
D		ADD OPERATING TEMPERATURE	MAY30/13	L.CHAN

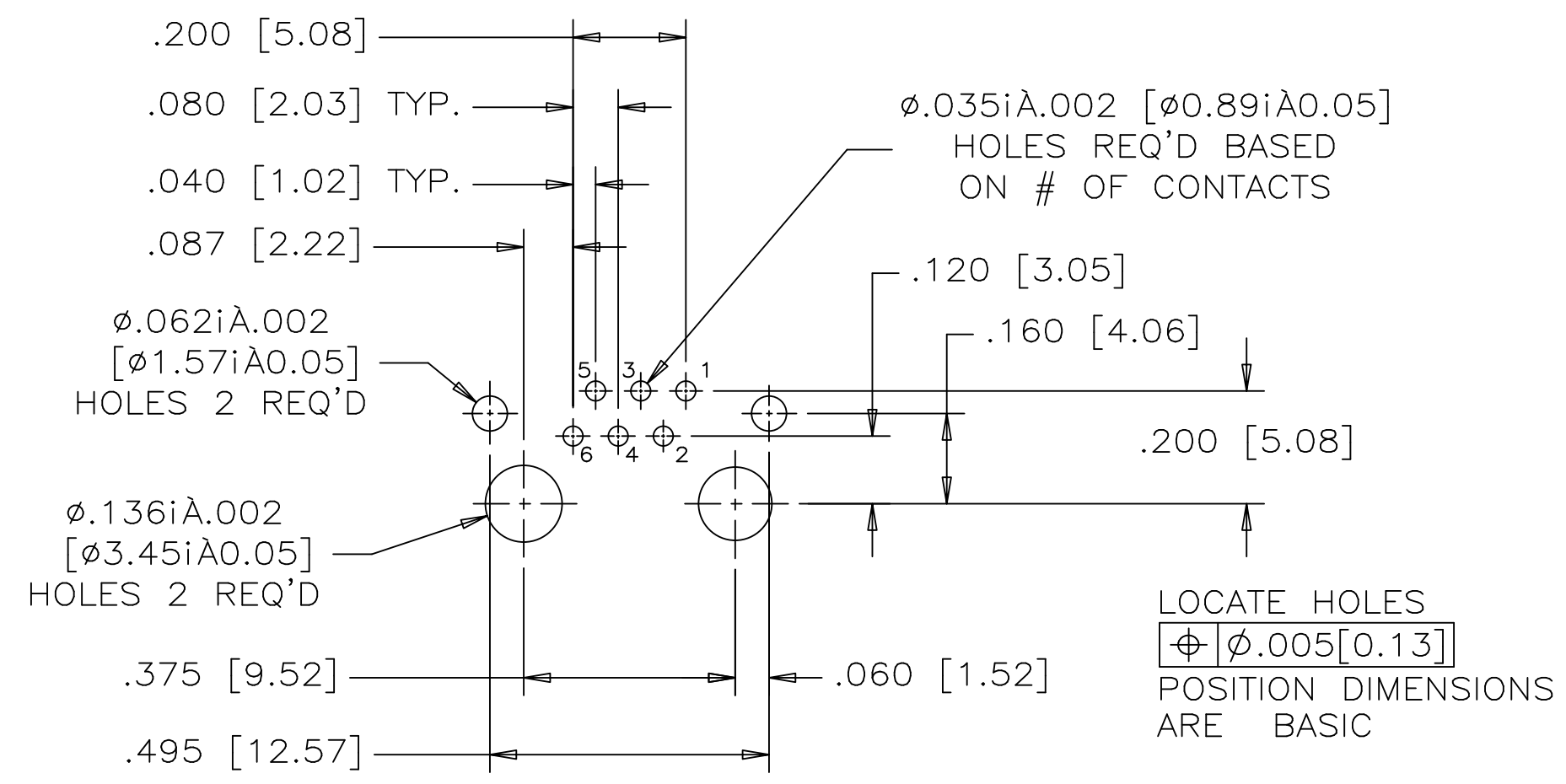
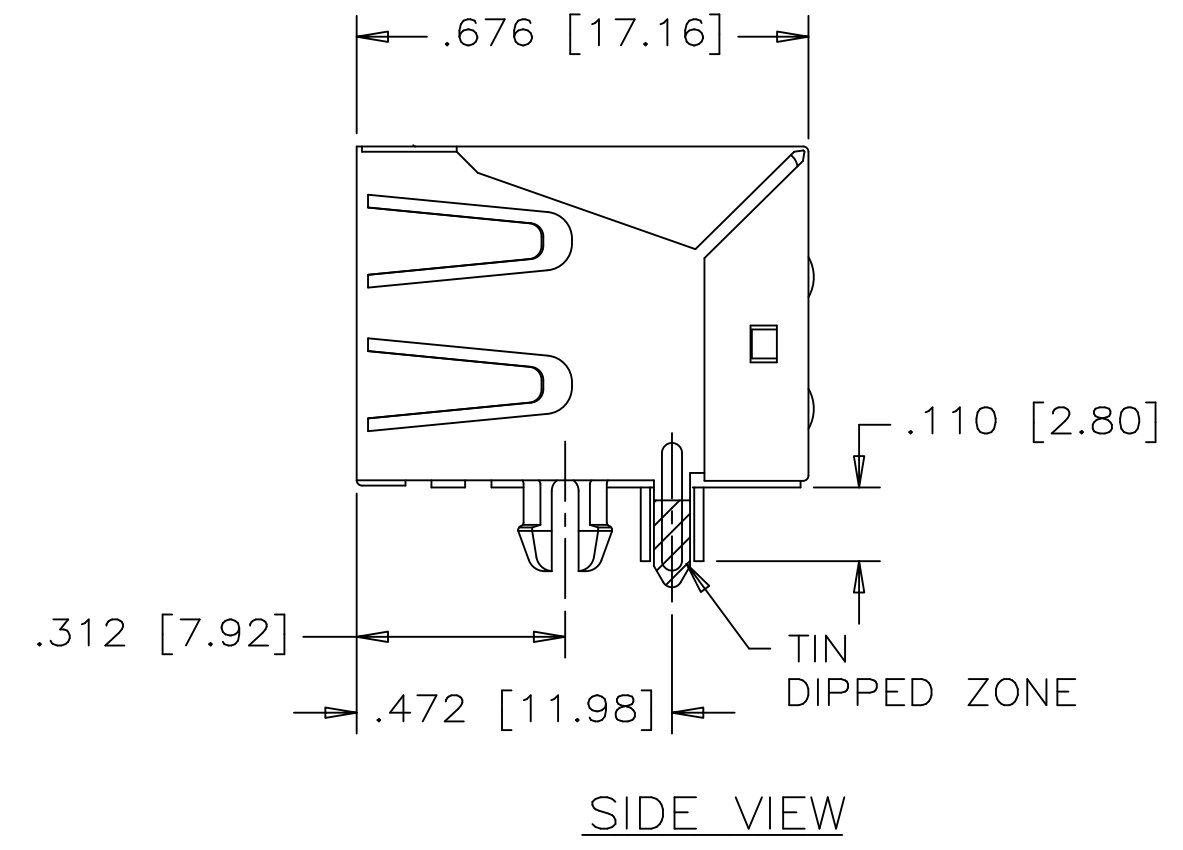
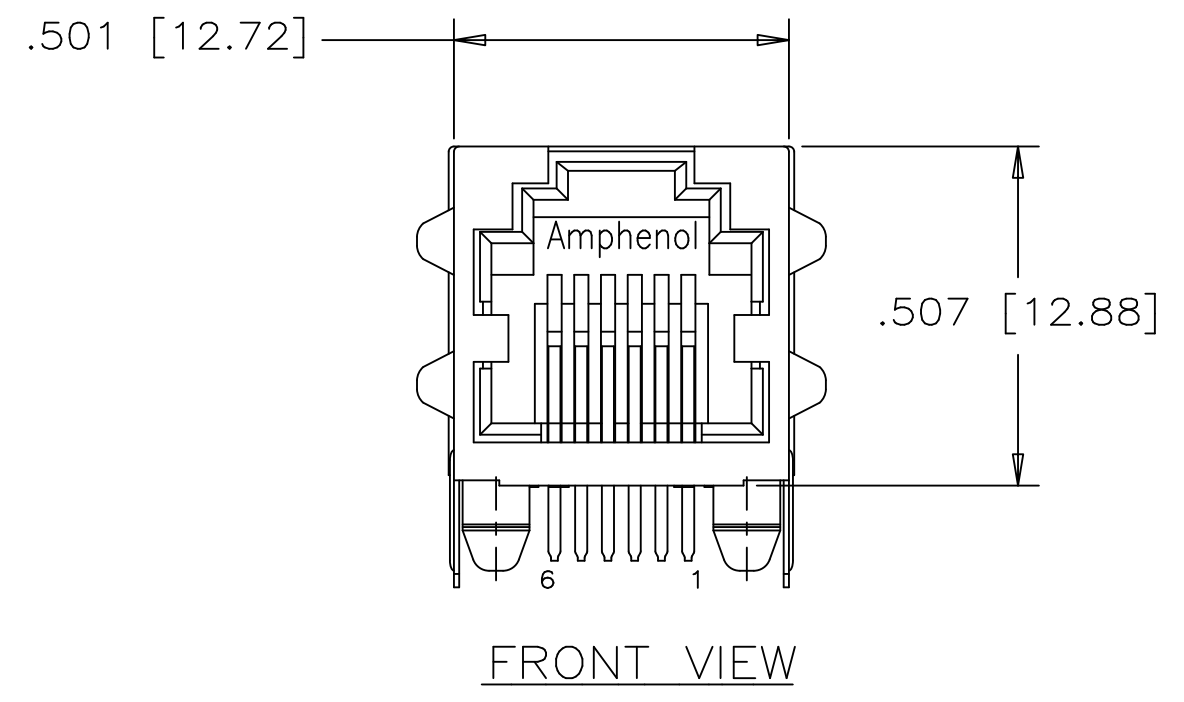

- MATERIALS:**
HOUSING: HIGH TEMPERATURE ENGINEERING THERMOPLASTIC FLAMMABILITY RATING UL 94V-0, BLACK

CONTACTS: PHOSPHOR BRONZE
 PLATING: 50 μ" [1.27 MICRONS] MIN. GOLD ON MATING SURFACES.
 50 μ" [1.27 MICRONS] MIN. NICKEL UNDERPLATE
 100 μ" [2.54 MICRONS] MIN. MATTE TIN ON CONTACT TAILS.

SHIELD: COPPER ALLOY
 PLATING: NICKEL WITH TIN DIPPED PCB TAILS.
- ENVIRONMENTAL:**
 OPERATING TEMPERATURE: -55°C to 85 °C
- RECOMMENDED SOLDERING TEMPERATURE:**
 WAVE SOLDERING OR REFLOW SOLDERING AT 260°C MAXIMUM FOR 5 SEC MAXIMUM.

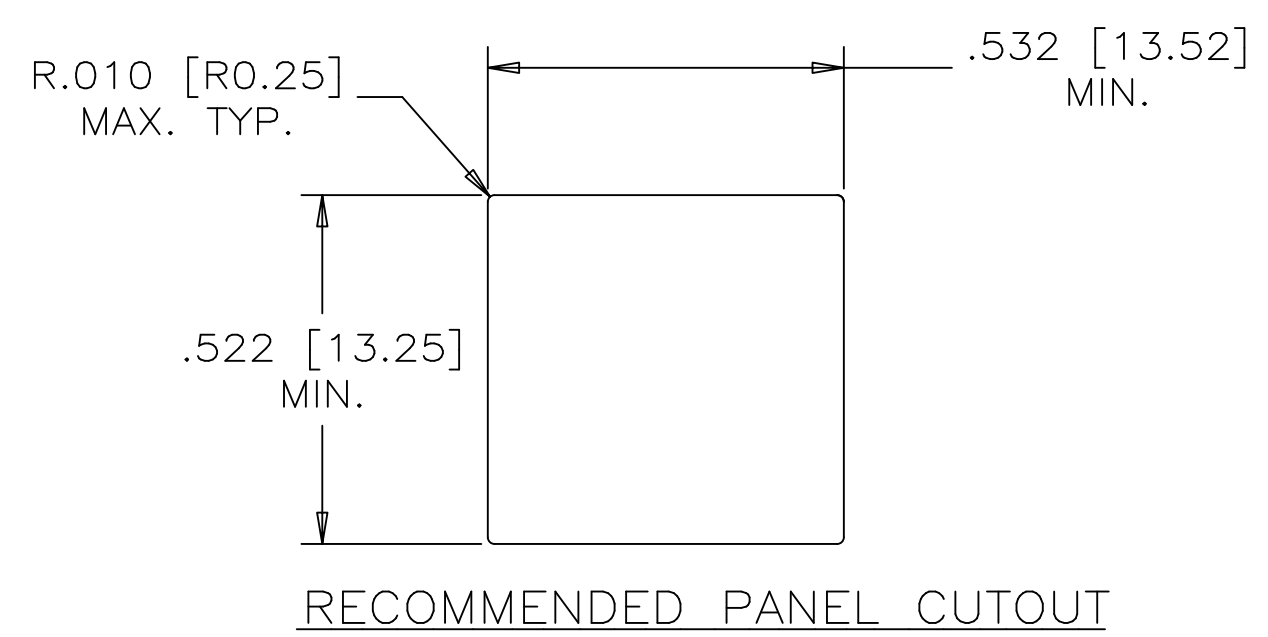

PART NUMBER: RJE01-6X2-01

- CONTACTS:**
 2 = 2 CONTACTS LOADED IN POSITION 3 & 4.
 4 = 4 CONTACTS LOADED IN POSITION 2 TO 5.
 6 = 6 CONTACTS LOADED IN POSITION 1 TO 6.



DRAWN	L.CHAN	DATE	OCT.25/04
DESIGNED			
CHECKED	K.LAMBIE	DATE	OCT.25/04
I. E. APPRD.			
Q. A. APPRD.			
DWG. APPRD.			
ENG. REL. NO.			
REF. EAR:	RJ13076		
DIMENSIONS ARE IN	CODE ID. NO.		
INCHES [mm]	03554		

Amphenol Canada Corp.			
TITLE HIGH SPEED MODULAR JACK, SINGLE PORT, EMI QUIET, 6 POSITION, SHIELDED WITH SIDE TABS- RoHS COMPLIANT			
DWG	DRAWING NO.	REV.	
	P-RJE01-6X2-01	D	
SCALE	WT. -----	SURF. -----	SHEET 1 OF 1

THIS DOCUMENT CONTAINS PROPRIETARY INFORMATION AND SUCH INFORMATION MAY NOT BE DISCLOSED TO OTHERS FOR ANY PURPOSE OR USED FOR MANUFACTURING PURPOSES WITHOUT WRITTEN PERMISSION FROM AMPHENOL CANADA CORP.