

Modular Programmable AC/DC/Loads Power System

- Truly Modular Design
- Digital System and Power Converter Control
- Control up to 95 assets across 8 mainframes
- Control multiple AC and DC power supplies and loads in one or more mainframes
- Create “virtual assets”
- Highest Power Density
- World-wide AC or DC input

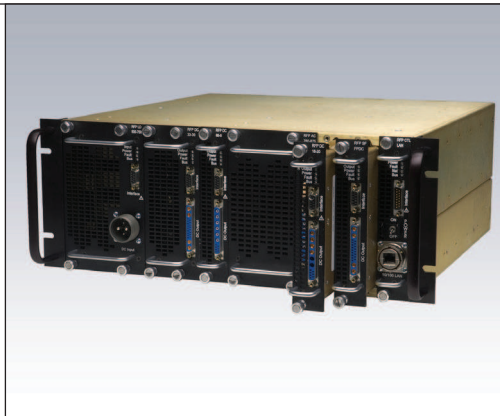

ReFlex Power™ is a high density, modular programmable power system providing DC, AC and electronic load assets all under control of a single controller. It provides a reconfigurable, flexible platform ideal for ATE and production test environments where RFP™ can provide programmable stimulus and bias power as well as programmable loads for the device(s) under test.

The EIA 4U high RFP™ Mainframe can hold up to 12 single-slot modules or combinations of single, dual and triple slot wide modules to configure (or reconfigure) the system for the particular requirements at hand. The mainframe can support up to 6 kW of output power.

Up to 8 mainframes, potentially up to 95 modules, can be controlled via a single controller. The controller communicates to the individual modules via a high speed proprietary bus protocol. The RFP™ controller communicates to the host controller via an Ethernet LAN connection designed in compliance with the LAN Extension for Instrumentation (LXI™) standard, assuring interoperability and ease of integration.

Virtual Output Channels

By using the powerful ReFlex Power software, the modules can be combined via the controller in series or parallel groups, or series / parallel arrays to form new assets, or “virtual outputs.” This can be accomplished “on the fly” within a test program, with no need to shut down and reconfigure modules.

This unique capability greatly extends the operating range of a ReFlex Power System, and establishes a new power stimulus paradigm. Virtual output channels reduce the overall asset count in any particular system, while increasing the range of voltage and currents available for DUT stimulus.

Virtual channels can be set up across mainframes, and multiple virtual channels can reside in a single mainframe or system.

By implementing this functionality in test systems or as part of an overall test strategy, users can reduce both up-front capital costs, as well as long term supply chain, logistics and support costs.

Available power modules include

Single slot, 330 Watt programmable DC supplies

- 16V, 20.6A
- 65V, 5.1A

Dual slot, 1kW programmable DC supplies

- 33V, 30A
- 50V, 20A
- 50V, 25A
- 120V, 8.3A
- 450V, 2.3A

Triple slot, 875 VA, single phase, programmable AC supply

- Dual range: 280V AC, 3.5A AC
- Dual Range: 140V AC, 7A AC

Triple slot, 500V, programmable electronic DC loads

- 375 Watt, 500V, 15A
- 375 Watt, 500V, 30A



Universal
AC/DC



AMETEK
Programmable Power
9250 Brown Deer Road
San Diego, CA 92121-2267
USA



Elgar ReFlex Power™ Series

Universal 12 Slot Mainframe

- Worldwide input voltage capability
 - 270 VDC input with relay control
- Input power and connectors for system expansion
- Fully configurable
- No active components
- Power output up to 3600W / 6000W

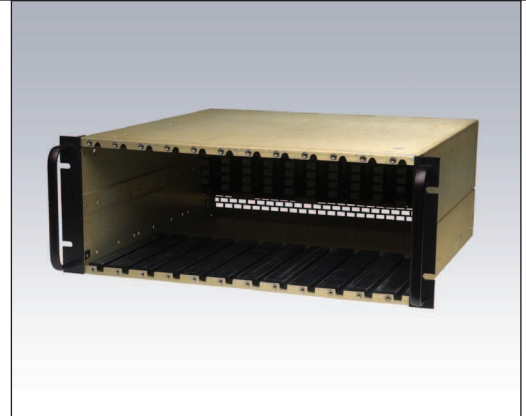

The ReFlex Power System™ Mainframe consists of 12 fixed pitch “slots” for insertion of AC, DC or Active load modules and the Controller which are one, two, or three “slots” wide.

Very compact in size, 4RU by 17.00” deep, the mechanical design is ruggedized for harsh environments including mobile applications as well as general-purpose industrial and laboratory rack-mount ATE.

The Mainframe connectors on the rear panel facilitate the connection to the AC mains and provide for extending the system to multiple frames, (up to eight). There are no active components in the mainframe, therefore once installed, would not normally have to be uninstalled. It also accommodates the easy

populating of the user system with the various power assets. The mainframe also contains the proprietary RFP backplane.

Any RFP module can be installed in any slot(s) in the mainframe. There is no Slot 0 designated in the power system for the controller. It can be installed in any location depending on the users desired configuration.

The Mainframe is available in three versions. The basic rack mount version, which installs flush with the front of a cabinet, a version which is set back by 4.0” to allow for cable space at the front of the cabinet, and a version which removes the front panel mounting ears to facilitate installation in portable systems. The setback version includes an optional removable front dress panel.

Two Slot 1000W / 1250W DC Power Modules

Mainframe Model Number	Description
RFP-M0000-001-0000	12 Slot Mainframe
RFP-M0000-001-1E00	12 Slot Mainframe with 90 ° input connector
RFP-M0000-001-1J00	12 Slot Mainframe with 90 ° input connector. No rack ears
RFP-M0000-REC-0000	12 Slot RECESSED Mainframe with front dress panel
RFP-M0000-REC-1E00	12 Slot RECESSED Mainframe with front dress panel and 90 ° input connector.
RFP-M0000-REC-2J00	12 Slot RECESSED Mainframe with front dress panel and 90 ° input connector. No rack ears.
RFP-M0000-REC-1K00	12 Slot RECESSED Mainframe with front dress panel
5609184-01	12 Slot RECESSED Mainframe with DC input relay connector
5380059-01	Chassis interconnect cable 36 inches **
5380059-02	Chassis interconnect cable 97 inches **
5380059-03	Chassis interconnect cable 135 inches **

Mainframe Optional Accessories

Part Number	Description
5380059-01	Chassis Slot Blanking Module
	AC Power Cords
5380317-01	2 M unterminated Power Cord w/ mainframe connector mate
5380554-01	2 M unterminated Power Cord for single-phase 125V, 20A connection
5380555-01	2 M unterminated Power Cord for single-phase 250V, 20A connection
5380556-01	2 M unterminated Power Cord for three-phase 120V/208V, 30A connection
	AC Mating Connector Kit
5380318-01	AC Input mainframe connector mate

All specifications are subject to change

Elgar ReFlex Power™ Series

Common	
Module Interface Backplane	Slot Positions: 12 slots Multi-module control interface
Configuration Guidelines	Up to 8 Chassis may be interconnected. Paralleled AC, DC and Load modules must be in adjacent slots and be like modules AC modules to be configured for multi-phase operation must be in adjacent slots.
Regulatory	Certified to UL 61010-1, CSA C22.2 No. 61010.1 and IEC/EN 61010-1. Compliance with EN61326 and FCC 21 CFR, Subpart J CE Mark is to EMC and LVD
Input	
Universal Input	AC 1 phase:115/120/200/208/230V ±10% AC 3 phase: 115/200 or 120/208V ±10% delta and wye AC 3 phase: 230/400V ±10% wye – neutral AC Voltage Range: 103.5V to 253V DC Voltage Range: 210V to 300V (314V for 2 sec.) Power Factor: ≥0.95
Frequency range	47Hz to 63Hz, DC
Input Connector	Amphenol, DL3102A24-10P
Mating Connector	Amphenol, DL3106A24-10P, Input cable and mating connector kits available
Environmental (Extended range available)	
Operating Temperature	-10° C to 50° C
Storage Temperature	-40° C to 70 °C
Humidity Range	95%, non-condensating
Altitude	up to 2,000 M
Shock and vibration	Class 3 Mil-PRF-28800F
Physical : Module Sizes	
Dimensions Single Slot	1.4" (35.6mm) W - 6.75" (171.5mm) H - 15" (381 mm) D
Dimensions Dual Slot	2.8" (71.1) W - 6.75" (171.5mm) H - 15" (381 mm) D
Dimensions Triple Slot	4.2" (106.7mm) W - 6.75" (171.5mm) H - 15" (381 mm) D

Common ReFlex Power Applications

Rackmount ATE Systems

High power density, a large number of output channels and 16-bit resolution, all under the control of a single Ethernet controller, greatly simplifies ATE system integration. The wide variety of voltage and current combinations and power density, created by up to 12 separately programmable DC channels in a compact 4U system, makes RFP the most compact ATE power system on the market. Combining this with the RFP AC and load channels in the same chassis and under the same controller, RFP can elegantly satisfy your most demanding ATE system power stimulus requirements.

Product Development

Testing and burn-in of aircraft flight hardware, DC-DC converters, automotive electronics and semiconductor components are just a few applications currently being tested with RFP. From simple DC voltage set points and AC sine waves to complex waveforms and triggers, RFP keeps pace with your product development power stimulus challenges.

Aerospace Testing

ReFlex Power is ideal for testing all types of flight hardware and aircraft auxiliary systems. AC power modules can be operated in single or three phase mode, and expanded from 875 VA single phase to 2,625VA three phase, or even 5,250 VA. By combining variable frequency AC power signals from 45 to 5,000Hz with DC assets in a single 4U mainframe, most modern avionics power stimulus can be delivered.

Process Control

Whether you are driving magnets for controlling ion beams for the manufacture of semiconductors or driving a current through electrolyte for precise control of a plating process, RFP is your ideal process control choice. RFP's small footprint with flexible configuration of DC, AC and load modules can solve the most complex process control challenges.

Research

A research environment presents some of the most demanding requirements on your test instrumentation. RFP's flexible sequencing and triggering supports your research needs. All too often, equipment that meets the needs of your current project does not meet the needs of your next project. RFP with its modular design protects your capital assets. The RFP architecture allows you to change to different DC voltage and current combinations, add AC and load modules and parallel and phase-lock modules. This allows RFP to support all your current and future laboratory needs.

All specifications are subject to change

Elgar ReFlex Power™ System Controller

Programmable System Control Module

- LXI Ethernet interface
- SRQ functionality embedded in VISA layer
- Operates as instrument or socket connection
- Up to 16 individual sessions simultaneously
- One controller for up to 95 discrete power assets
- Modular
- IVI drivers available



The ReFlex Power™ (RFP™) System Controller (RFPC) provides a single command and status communication port for all power assets (power supplies and loads) within the RFP™ system. The RFP™ architecture is essentially a distributed processor system, and the role of the RFPC is command interpreter and redirector, plus manager of module status messages.

The unique features of the RFP™ system of configurability and extensibility are made possible through the use of the latest in controls technology. An FPGA-based implementation uses VHDL, embedded processor cores for firmware based systems control, ARCnet™ inter-module communication and LAN system communications.

The LAN network interface conforms to IEEE 802.3 standard, and is certified LXI class C compliant. Network transmission rates up to 100 Mbps conforming to 10 BASE-T and 100 BASE-TX specifications are supported. The RFP™ Controller (RFPC) module functions under remote control through a host controller. The module serves as a communications portal between the power supply modules and the remote host controller. All aspects of operation can be achieved through use of commands that comply with the requirements of the SCPI Standard 1999 command language.

Additional discrete digital control signals are available for dedicated hardware interface. All connectors for control are accessible on the front panel.

Single Slot LXI Ethernet Controller Module

Control Module Model Number	Description
RFP-C1LAN-000-0000	LXI Ethernet Interface: Ver 2 Firmware
RFP-C1LAN-000-1F00	LXI Ethernet Interface: Ver 2 Firmware + Ext'd Operating Temperature
RFP-C1LAN-000-001B	LXI Ethernet Interface: Ver 3 Firmware
RFP-C1LAN-000-1F1B	LXI Ethernet Interface: Ver 3 Firmware + Ext'd Operating Temperature

Control Module Model Optional Accessories

Part Number	Description
5380441-01	Controller 15-pin Dsub 9 foot cable
5380441-03	Controller 15-pin Dsub 9 foot cable (90 degree bend)
5380509-01	Controller interlock shorting connector (Don't order w/ cable (5380441-xx) above)
5380269-01	Connector Mating Kit

Ethernet Controller General Specifications

Function	Description
Modules Controlled	AC, DC and active Load Modules in RFP Mainframe(s)
Command Language	SCPI Standard 1997 command language via downloadable IVI Drivers
Control Interface	To host: LXI class C Ethernet
	To Module: Proprietary high speed bus protocol
Front Panel Switch	Standby switch, disables output but does not disconnect the input power
Front Panel Connectors	Interface Connector: Subminiature D
Input	VIA RFP backplane: Hold-up-time: 10ms

Elgar Reflex Power™ System DC Power Modules

1000 W

Programmable 1000 / 1250W High Power DC Modules and Accessories

33 - 450 V

- Near Linear Performance
- Truly Modular
- ≥0.95 PFC
- Digital control loop technology
- High Power Density (3.5 watts/cubic inch)
- “Virtual Assets” by:
 - Series operation
 - Parallel operation
 - Combined operation with loads
- Precision Hardware & Software Triggers
- Simple integration



2.3 - 30 A

~	Universal AC/DC
---	--------------------



The High Power DC supplies of the ReFlex Power™ (RFP™) system include models rated at 1kW and 1250W. They are part of a modular family of power assets that integrate into the RFP™ Mainframe to provide a wide range of features, functionality, and extensive configurability and adaptability.

The DFI signal can be programmed to provide shutdown of modules in fault groups established by the user.

The modules can be programmed to operate as standalone assets, or in combinations of parallel, series, and series / parallel groups to extend their voltage, current, and power ratings. System shut down is not required to implement groups and multiple groups can be set up in a single system. This “on the fly” characteristic sets the ReFlex Power™ System apart from competitive products.

Used together or individually, these signals can be utilized to improve system performance, increase test through-put, reduce system idle time and assure the highest level of safety for the Device Under Test.

The DB-9 connector on the front panel of each module provides variety of hardware interface lines. Included are Direct Fault Interrupt (DFI), Remote Inhibit (RI) and Trigger IN / Trigger OUT signals. Safety, ease of integration and functionality are significantly enhanced by these functions.

RFP™ system of DC power supplies brings true modularity to DC power assets, and makes possible a high degree of configurability and adaptability through a mainframe-based architecture. The mechanical design is ruggedized for harsh environments, including mobile applications, as well as general-purpose industrial and laboratory rack-mount ATE.

An advanced thermal design features integral, variable speed fans. Cooling performance scales based upon the complement of modules in the Mainframe and their output loading. This feature conserves energy, minimizes audible noise and enhances system reliability.

Two Slot 1000W / 1250W DC Power Modules		
1000W / 1250W Model Number	Description	Firmware Version
RFP-D2033-030-1G00	33Vdc, 30A, w/ Output Relay	Ver 2 Firmware
RFP-D2033-030-2D00	33Vdc, 30A, w/ Output Relay + Ext'd Operating Temperature	Ver 2 Firmware
RFP-D2050-020-1G00	50Vdc, 20A, w/ Output Relay	Ver 2 Firmware
RFP-D2050-020-2D00	50Vdc, 20A, w/ Output Relay + Ext'd Operating Temperature	Ver 2 Firmware
RFP-D2050-025-1G00	50Vdc, 25A, w/ Output Relay	Ver 2 Firmware
RFP-D2050-025-2D00	50Vdc, 25A, w/ Output Relay + Ext'd Operating Temperature	Ver 2 Firmware
RFP-D2120-8A3-1G00	120Vdc, 8.3A, w/ Output Relay	Ver 2 Firmware
RFP-D2120-8A3-2D00	120Vdc, 8.3A, w/ Output Relay + Ext'd Operating Temperature	Ver 2 Firmware
RFP-D2450-2A3-1G00	450Vdc, 2.3A, w/ Output Relay	Ver 2 Firmware
RFP-D2450-2A3-2D00	450Vdc, 2.3A, w/ Output Relay + Ext'd Operating Temperature	Ver 2 Firmware
RFP-D2033-030-1G1B	33Vdc, 30A, w/ Output Relay	Ver 3 Firmware
RFP-D2033-030-2D1B	33Vdc, 30A, w/ Output Relay + Ext'd Operating Temperature	Ver 3 Firmware
RFP-D2050-020-1G1B	50Vdc, 20A, w/ Output Relay	Ver 3 Firmware
RFP-D2050-020-2D1B	50Vdc, 20A, w/ Output Relay + Ext'd Operating Temperature	Ver 3 Firmware
RFP-D2050-025-1G1B	50Vdc, 25A, w/ Output Relay	Ver 3 Firmware
RFP-D2050-025-2D1B	50Vdc, 205, w/ Output Relay + Ext'd Operating Temperature	Ver 3 Firmware
RFP-D2120-8A3-1G1B	120Vdc, 8.3A, w/ Output Relay	Ver 3 Firmware
RFP-D2120-8A3-2D1B	120Vdc, 8.3A, w/ Output Relay + Ext'd Operating Temperature	Ver 3 Firmware
RFP-D2450-2A3-1G1B	450Vdc, 2.3A, w/ Output Relay	Ver 3 Firmware
RFP-D2450-2A3-2D1B	450Vdc, 2.3A, w/ Output Relay + Ext'd Operating Temperature	Ver 3 Firmware

Elgar ReFlex Power™ Series

Optional Module Accessories and Output Cables

Ametek offers output load cables for each RFP™ module type. Cables mate directly to the modules and are 3 M long and unterminated. The cables are sized appropriately for the rated module current and include sense leads.

Also available are mating connector kits for each connector type used in the system. A module interlock shorting connector must be installed in order to enable any module. These are provided free of charge, but must be ordered on the purchase order.

DC Power Module Optional Accessories

Part Number	Description
5380444-01	16Vdc 9 foot output cable
5380444-03	16Vdc 9 foot output cable - 90 degree bend for shorter bend radius
5380445-01	65Vdc 9 foot output cable
5380445-03	65Vdc 9 foot output cable - 90 degree bend for shorter bend radius
5380446-01	33Vdc/50Vdc 9 foot output cable
5380446-03	33Vdc/50Vdc 9 foot output cable - 90 degree bend for shorter bend radius
5380453-01	120Vdc 9 foot output cable
5380453-03	120Vdc 9 foot output cable - 90 degree bend for shorter bend radius
5380447-01	450Vdc 9 foot output cable
5380447-03	450Vdc 9 foot output cable - 90 degree bend for shorter bend radius
5380443-01	Module 9-pin D-sub 9 foot cable
5380443-03	Module 9-pin D-sub 9 foot cable (90 degree bend)
5380508-01	Module interlock shorting connector (Don't order w/ cable (5380443-xx) above)
5380270-01	16Vdc Connector Mating Kit
5380270-02	65Vdc Connector Mating Kit
5380271-01	33Vdc/50Vdc Connector Mating Kit
5380271-03	120 Vdc Connector Mating Kit
5380271-02	450Vdc Connector Mating Kit

AC Power Module Optional Accessories

Part Number	Description
5380450-01	AC 9 foot output cable
5380450-03	AC 9 foot output cable - 90 degree bend for shorter bend radius
5380443-01	Module 9-pin D-sub 9 foot cable
5380443-03	Module 9-pin D-sub 9 foot cable (90 degree bend)
5380508-01	Module interlock shorting connector (Don't order w/ cable (5380443-xx) above)
5380272-01	AC Output Connector Mating Kit

Active Load Module Optional Accessories

Part Number	Description
5380452-01	DC Loads 9 foot output cable
5380443-01	Module 9-pin D-sub 9 foot cable
5380443-03	Module 9-pin D-sub 9 foot cable (90 degree bend)
5380508-01	Module interlock shorting connector (Don't order w/ cable (5380443-xx) above)
5380273-01	DC Load Connector Mating Kit
5380272-01	AC Output Connector Mating Kit

Elgar Reflex Power™ System DC Power Modules

330 W

Programmable 300W Low Power DC Modules and Accessories

16 - 65 V

- Near Linear Performance
- Truly Modular
- ≥ 0.95 PFC
- Digital control loop technology
- High Power Density (3.5 watts/cubic inch)
- "Virtual Assets" by:
 - Series operation
 - Parallel operation
 - Combined operation with loads
- Precision Hardware & Software Triggers
- Simple integration



5.1 - 20.6 A



Universal
AC/DC



The Low Power DC supplies of the ReFlex Power™ (RFP™) system are rated at 330W, They are part of a modular family of power assets that integrate into the RFP™ Mainframe to provide a wide range of features, functionality, and extensive configurability and adaptability.

The modules can be programmed to operate as standalone assets, or in combinations of parallel, series, and series / parallel groups to extend their voltage, current, and power ratings.

The DB-9 connector on the front panel of each module provides variety of hardware interface lines. Included are Direct Fault Interrupt (DFI), Remote Inhibit (RI) and Trigger IN / Trigger OUT signals. Safety, ease of integration and functionality are significantly enhanced by these functions.

The DFI signal can be programmed to provide shutdown of modules in fault groups established by the user.

Used together or individually, these signals can be utilized to improve system performance, increase test through-put, reduce system idle time and assure the highest level of safety for the Device Under Test.

RFP™ system of DC power supplies brings true modularity to DC power assets, and makes possible a high degree of configurability and adaptability through a mainframe-based architecture. The mechanical design is ruggedized for harsh environments, including mobile applications, as well as general-purpose industrial and laboratory rack-mount ATE.

An advanced thermal design features integral, variable speed fans. Cooling performance scales based upon the complement of modules in the Mainframe and their output loading. This feature conserves energy, minimizes audible noise and enhances system reliability.

Single Slot 300W DC Power Modules		
300W Model Number	Description	Firmware Version
RFP-D1016-021-1G00	16Vdc, 20.6A, w/ Output Relay	Ver 2 Firmware
RFP-D1016-021-2D00	16Vdc, 20.6A, w/ Output Relay + Ext'd Operating Temperature	Ver 2 Firmware
RFP-D1065-5A1-1G00	65Vdc, 5.1A, w/ Output Relay	Ver 2 Firmware
RFP-D1065-5A1-2D00	65Vdc, 5.1A, w/ Output Relay + Ext'd Operating Temperature	Ver 2 Firmware
RFP-D1016-021-1G1B	16Vdc, 20.6A, w/ Output Relay	Ver 3 Firmware
RFP-D1016-021-2D1B	16Vdc, 20.6A, w/ Output Relay + Ext'd Operating Temperature	Ver 3 Firmware
RFP-D1016-021-1G1B	65Vdc, 5.1A, w/ Output Relay	Ver 3 Firmware
RFP-D1016-021-2D1B	65Vdc, 5.1A, w/ Output Relay + Ext'd Operating Temperature	Ver 3 Firmware

ReFlex Power™ DC Power Modules : Specifications

DC Modules General Specifications	
Regulation	
Steady State, Voltage Mode	0.01% of full-scale + 10mV (330W) and 0.03% of full-scale (1/1.2kW) for 10% line or 100% load change
Steady State, Current Mode	0.05% of full scale (330W) and 0.1% of full-scale (1/1.2 kW) for 10% line change. Less than 0.1% of full-scale for 100% load change
Load Transient	<5% of full scale maximum excursion returning to steady state value within 0.5% of full scale in 2 ms maximum, for 90% load step above and below 50% nominal load.
Remote Sense	Up to 3V total load line drop. The drop in the load leads subtracts from the maximum voltage available for the load.
Parallel Operation	Up to six like modules.
Series Operation	Up to five like modules for 16V, 65V; Up to three like models for 33V, 50V, 120V, Float not to exceed 200V (16V, 33V, 50V, 120V), 300V (65V), 450V (450V). Note: 120V and 450V cannot be placed in series.
Sag/Surge/Hold Up Time	Sag to 65% of nominal for 450ms at full output power with AC input at $\geq 200VAC$. Surge to 135% of nominal for 450ms at full output with AC input $\leq 230VAC$. 10ms hold up at loss of input: 8ms hold up for 50V above 20A.
Remote programming connector	9-pin D-sub miniature
Power Output Connector	Combination signal/power contact subminiature D (Output cables and Mating Connector kits available)
Trigger Latency	5 micro-seconds typical.

DC Low Power		
Output Voltage	0-16V	0-65V
Maximum Output Current	20.6A	5.1A
Maximum Power	330W	330W
Output rise/fall time	20msec	20msec
Mainframe Slots	1	1
Ripple / Noise		
RMS (20 Hz - 300 kHz)	5mV	6mV
Peak-Peak (20 Hz - 20 MHz)	25mV	18mV
Programming Accuracy		
Voltage (0.05% of setpoint + ...)	10mV	32.5mV
Current (0.1% of setpoint + ...)	21mA	5.1mA
Resolution	0.47 mV/1.28 mA	1.9 mV/0.32 mA
Temperature Coefficient		
Voltage /°C	1.6mV	6.5mV
Current /°C	5mA	1mA

DC High Power					
Output Voltage	0-33V	0-50V	0-50V	0-120V	0-450V
Maximum Output Current	30A	20A	25A*	8.3A	2.3A
Maximum Power	990W	1000W	1250W*	996W	1035W
Output rise/fall time	20msec	20msec	20msec	20msec	20msec
Mainframe Slots	2	2	2	2	2
Ripple / Noise					
RMS (20 Hz - 300 MHz)	15mV	20mV	20mV	20mV	40mV
Peak-Peak (20 Hz - 20 MHz)	60mV	75mV	75mV	75mV	200mV
Programming Accuracy					
Voltage (0.05% of setpoint + ...)	16.5mV	25mV	25mV	60mV	225mV
Current (0.2% of setpoint + ...)	30mA	20mA	25mA	10mA	2.3mA
Resolution	2 mV/1.9 mA	3 mV/1.3 mA	3 mV/1.6 mA	7 mV/0.6 mA	28 mV/0.14 mA
Temperature Coefficient					
Voltage /°C	3.3mV	5mV	5mV	12mV	45mV
Current /°C	9mA	6mA	7.5mA	2.5mA	0.7mA

* 1250 Watt module must have an AC Input voltage above 188 VAC or DC input above 210 VDC. The Module will not operate below the required input line voltage.

All specifications are subject to change

Elgar ReFlex Power™ AC Power Modules

875 VA

High Density Programmable AC Power Modules

140–280 VAC

- Single or multi-phase output
- Parallel operation up to 5250 VA, 3 phase
- 4.8 Crest factor
- Digital control loop technology
- Brown out protection to 65% of nominal input line
- Up to 875 VA
- 45 to 1200 Hz or 5000 Hz
- Universal AC/DC input via mainframe



3.5–7 Arms



Universal
AC/DC



The ReFlex Power™ (RFP™) system includes an AC power source rated at 875VA with two output voltage ranges, 0-140VAC and 0-280VAC.

This AC source module is part of a modular family of power assets that integrate into the RFP™ Mainframe to provide a wide range of features, functionality and extensive configurability and adaptability.

The AC module can be set up to operate as a standalone asset, in combinations of parallel or in multi-phase groups to extend their voltage, current, and power rating.

The DB-9 connector on the front panel of each module provides Remote Inhibit (RI). This allows the user to turn on / off individual modules with a hardware interface. This function enhances safety and ease of integration.

The RFP AC Power module provides a very robust output, with surge rating of 140% (5A / 7A or 7A / 10A) and a crest factor rating of 4.8:1.

Two frequency options are available to satisfy most avionics, commercial and industrial test requirements; 45Hz to 1200Hz or 45 to 5000Hz. The module utilizes high-frequency power conversion for high efficiency to maximize power density and realize lightweight and small size.

Weighing only 11.4 lb., a three phase 2625 VA power system weighs only 50lbs. and can be expanded to 5250 total VA in only 8U of rack elevation.

An advanced thermal design features integral, variable speed fans. Cooling performance scales based upon the complement of modules in the Mainframe and their output loading. This feature conserves energy, minimizes audible noise and enhances system reliability.

Three Slot 875VA AC Power Modules

AC Model Number	Description	Firmware Version
RFP-A301K-875-1G00	875VA, 45-1.2 kHz w/ Output Relay	Ver 2 Firmware
RFP-A301K-875-2D00	875VA, 45-1.2 kHz w/ Output Relay + Ext'd Operating Temperature	Ver 2 Firmware
RFP-A305K-875-1G00	875VA, 45-5.0 kHz w/ Output Relay	Ver 2 Firmware
RFP-A305K-875-2D00	875VA, 45-5.0 kHz w/ Output Relay + Ext'd Operating Temperature	Ver 2 Firmware
RFP-A301K-875-1G1B	875VA, 45-1.2 kHz w/ Output Relay	Ver 3 Firmware
RFP-A301K-875-2D1B	875VA, 45-1.2 kHz w/ Output Relay + Ext'd Operating Temperature	Ver 3 Firmware
RFP-A305K-875-1G1B	875VA, 45-5.0 kHz w/ Output Relay	Ver 3 Firmware
RFP-A305K-875-2D1B	875VA, 45-5.0 kHz w/ Output Relay + Ext'd Operating Temperature	Ver 3 Firmware

ReFlex Power™ AC Power Modules : Specifications

AC Modules General Specifications	
Continuous Current	7A, maximum for 0-140VAC range, 3.5A, maximum for 0-280VAC range.
Surge Current	10A, maximum for 0-140VAC range up to 125VAC, derated linearly to 8.93A at 140VAC; 5A, maximum for 0-280VAC range up to 250VAC, derated linearly to 4.46 at 280VAC, time duration of 0.5s, maximum.
Frequency	45-1200 Hz, up to 5 kHz optional
Crest Factor	4.8 X FS rms current
Voltage Regulation, Line & Load	Voltage mode 0.1% of full scale. 100% resistive load change or 10% line change from nominal.
Programming Accuracy	Voltage $\pm(0.1\% + .2\%/kHz)$ of full scale from 0.25% to 102% of range; Current $\pm(0.5\% + 0.75\%/kHz)$ of full scale from 2% to 102% of range; Frequency $(0.01\% + 0.01\%/kHz)$ of setpoint
Programming Resolution	Voltage 0-140VAC 20mV, 0-280 40mV Current 5mA Frequency 0.1Hz thru 1kHz; 0.5Hz thru 5KHz
Temperature Drift	Voltage .05% of full scale per °C Current .05% of full scale per °C
Voltage Distortion (Resistive Load)	<1% to 500Hz <2% to 2kHz <5% to 5kHz
Output DC Offset	0.1VDC maximum
Efficiency	(72% - 1.4%/kHz) at full output power and 115VAC input, and no load on auxiliary output, typical
Noise	55dB below full scale, typical; RMS value measured with output at 50Hz and with a bandwidth from 10kHz to 20MHz
Hold-up time	Dropout of AC input to zero for 10ms at full output power
Remote Sense	0.75Vrms per load line
Overvoltage Protection	Range: 1.4% to 110% Accuracy: 2% of setpoint
Overcurrent Protection	Range: 0.4% to 106% Accuracy: 3% of setpoint
Auxiliary AC Output	Isolated, 0Vac to 31.6Vac, 2A max, tracks main output (140 VAC range) at 22.6% of output from 350Hz - 1kHz
Cooling	required at full load & max temperature. 40CFM airflow at altitude and ambient temperature
Parallel Operation	Up to 6 Modules (must be located contiguously in mainframe.)
Multi-phase Operation	Up to 6 Delta and wye loads are supported. Modules must be configured as wye sources (neutrals connected).
Phase Programming Range	0-360 degree; with respect to A-phase; any module could be an A-Phase (the master); adjacent modules to the right of A-Phase would be B-Phase and C-Phase; counterclockwise phasor rotation is assumed, therefore the phase angle offset is lagging the master reference.
Phase Programming Accuracy	1 degree plus 1°/kHz for balanced resistive load measured with respect to A-phase
Remote programming connector	9-pin D-sub miniature
Output connector	Combination signal/power contact subminiature D (Out cables and mating connector kits available)

All specifications are subject to change

Elgar ReFlex Power™ Active Load Modules

375–750 W

High Density Programmable Active Load Modules

500 V

- High Voltage (500V) Input
- Digital control loop technology
- Two models: 375 W & 750 W
- Up to 15 A or 30 A
- Parallel up to 8 automatically
- Modular
- High Power Density
- Simple integration

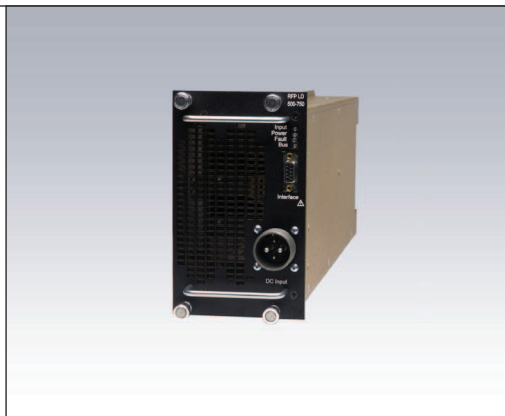

15–30 A



Universal
AC/DC

LXI ETHERNET

The High Power Active Load (HPAL) and the Low Power Active Load (LPAL) of the ReFlex Power™ (RFP™) system include models rated at 750 W and 350 W. They are part of a modular family of power assets that integrate into the RFP™ Mainframe to provide a wide range of features, functionality, and extensive configurability and adaptability.

The 500V provide an exceptional range of operation. They can be set up to operate as standalone assets, or in combinations of parallel groups to extend their current, and power ratings up to as high as 180 A and nearly 4000W in a single mainframe.

The DB-9 connector on the front panel of each module provides Remote Inhibit (RI). This allows the user to turn on / off individual modules with a hardware interface. This function enhances safety and ease of integration. Remote analog programming is also available, allowing the user to modulate the load with a hardware line.

The modules utilize FET active current sinks in modular form to get the flexibility of the two power ranges. The 375 W module is housed in a triple-width enclosure, and weighs 8.2 lb. The 750 W module is also triple-width, and weighs 12.9 lb.

Two modes of operation are available. Current mode up to 30A and resistive mode, programmable 0 to 5000 ohms in three ranges. In addition, each Active Load can be controlled independently with an analog signal to control or modulate the output with an external signal.

An advanced thermal design features integral, variable speed fans. Cooling performance scales based upon the complement of modules in the Mainframe and their output loading. This feature conserves energy, minimizes audible noise and enhances system reliability.

Three Slot 500V, 15A or 30A Active Load Modules

Active Load Model Number	Description	Firmware Version
RFP-D3500-375-1G00	500Vdc, 15A w/ Output Relay	Ver 2 Firmware
RFP-D3500-375-2D00	500Vdc, 15A w/ Output Relay + Ext'd Operating Temperature	Ver 2 Firmware
RFP-D3500-750-1G00	500Vdc, 30A w/ Output Relay	Ver 2 Firmware
RFP-D3500-750-2D00	500Vdc, 30A w/ Output Relay + Ext'd Operating Temperature	Ver 2 Firmware
RFP-D3500-375-1G1B	500Vdc, 15A w/ Output Relay	Ver 3 Firmware
RFP-D3500-375-2D1B	500Vdc, 15A w/ Output Relay + Ext'd Operating Temperature	Ver 3 Firmware
RFP-D3500-750-1G1B	500Vdc, 30A w/ Output Relay	Ver 3 Firmware
RFP-D3500-750-2D1B	500Vdc, 30A w/ Output Relay + Ext'd Operating Temperature	Ver 3 Firmware

ReFlex Power™ Active Load Modules : Specifications

DC Loads Modules General Specifications		
Physical	Size: 3 RFP Slots, Weight 8.2 lbs (375W); 12.9 lbs (750W)	
Connectors	DC Input and Sense: MS3106F-20-24S Remote Programming: 9 pin D-Sub (Output cables and mating connector available)	
Current Stability	<0.1% of full scale after 8 hrs	
Current Temperature Drift	<0.05% of full scale/°C	
Protection	Overvoltage: 525V ± 3%, Overcurrent: 20A ± 3% (375W), 40A ± 3% (750W) Overpower: 19-394W ± 5% (375W), 38 – 788W ± 5% (750W), Reverse Voltage: -15V ± 1V	
Parallel Operation	Up to 8 modules.	
Noise	30mA (pk-pk) (375W), 90mA (pk-pk)(750W), 20 Hz to 20 MHz bandwidth	
Programming Response Time	55ms	
Dynamic Response (10 - 90%/90 to 10%)	50µs	
Remote Sense	0.75V per source line	
Max Float Voltage	500VDC any input terminal to chassis	
Cooling	Internal fans, require 110 CFM minimum airflow with full power and at maximum altitude and ambient temperature	
All specifications	25°±5°C.	
Digital Voltage Measurement		
Range	0-500V	
Resolution	33mV	
Accuracy	0.1% of FS	
Digital Current Measurement	375W	750W
Range	0-15A	0-30A
Resolution	1.0mA	2.0mA
Accuracy	0.3% of full scale	0.3% of full scale
Current Mode	375W	750W
Range	0-15A	0-30A
Resolution	1.0mA	2.0mA
Digital Programming Accuracy	0.3% of full scale	0.3% of full scale
Regulation	0.1% of full scale for 100% load change	0.1% of full scale for 100% load change
Resistance Mode		
Range 1, Resolution	1-99Ω, 1Ω resolution with Current ≥ 1% of FS	
Range 2, Resolution	100-1000Ω, 100Ω full scale resolution with Current ≥ 1% of FS	
Range 3, Resolution	1000-5000Ω, 1000Ω full scale resolution with Current ≥ 1% of FS	
Digital Programming Accuracy	5% of setpoint. full scale with Current ≥ 10% of FS	
Load Transient	60 msec to set point	
Analog Control (Current Mode)		
Range	0 to 10V = zero to full scale	
Accuracy	0.3% of full scale + digital accuracy	
Bandwidth	8kHz @ -3dB	
DC Input Ratings	375W	750W
Voltage	500V	500V
Current	15A	30A
Power	375W	750W
Min Voltage, Full Load	3V	3V

All specifications are subject to change

Elgar ReFlex Power™ Diagram

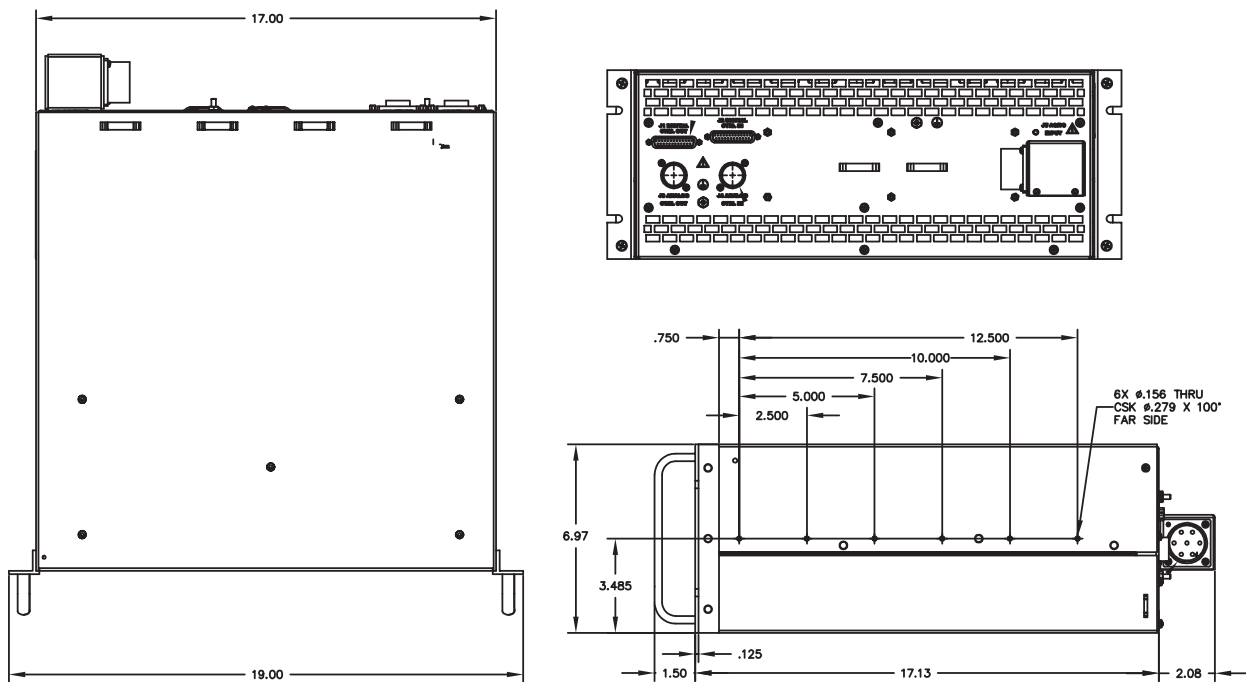

Standard Chassis with 90 degree connector shown

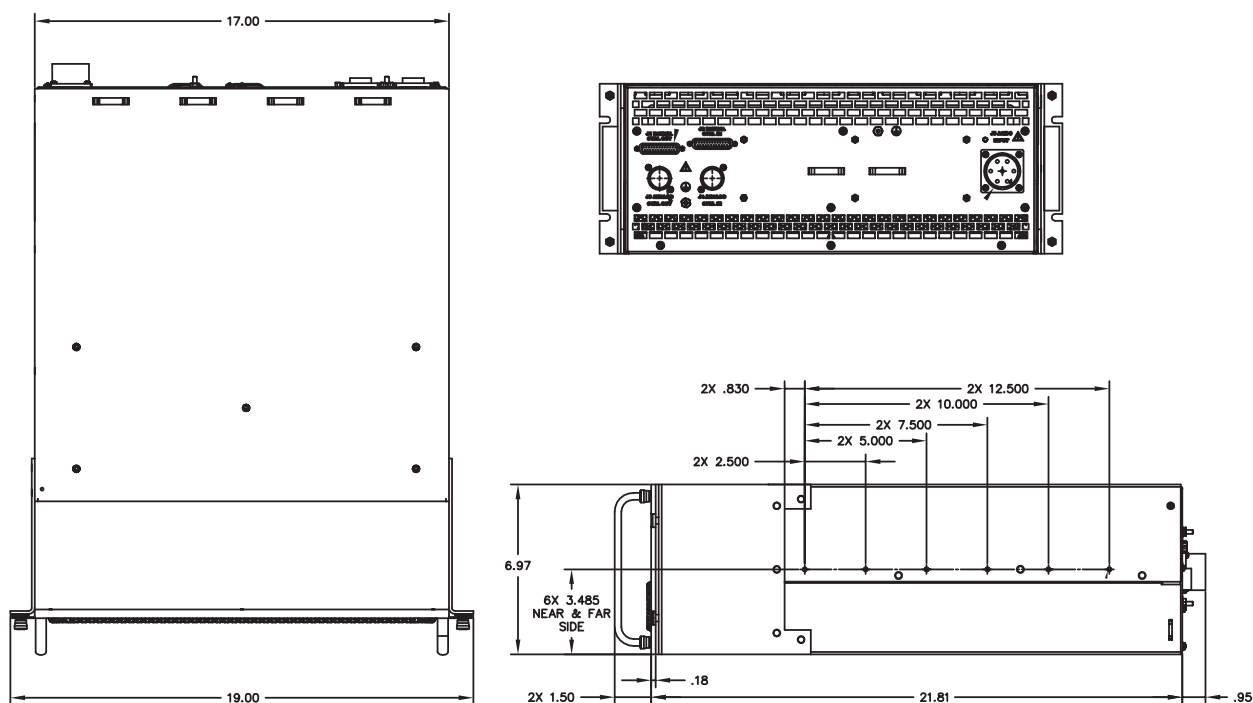

Recessed Chassis with straight connector shown

Elgar ReFlex Power™ Diagram

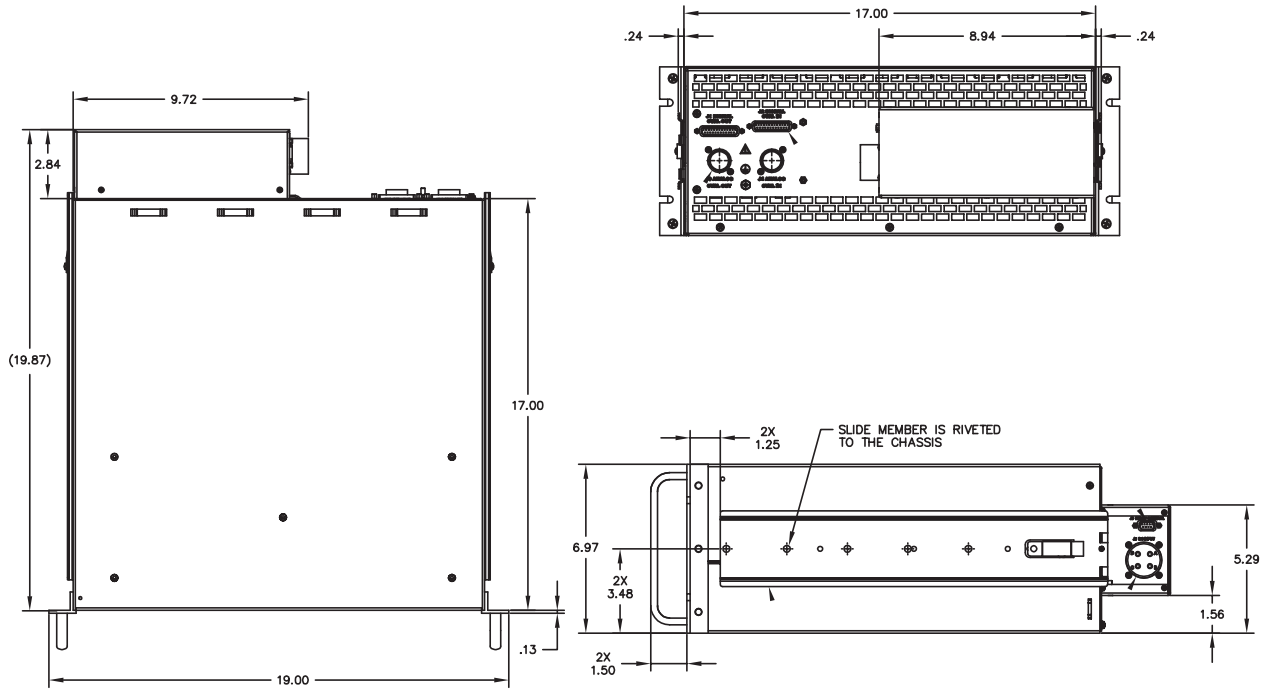

5609184-01 Chassis (DC input with contactor and 90 degree input connector)