

Sorensen SG Series - Water Cooled

5–75 kW

Programmable Precision High Power DC Power Supply

40–60 V

- High Power Density: up to 15 kW in 3U
- Wide Voltage Range: 0-40 V and 0-60 V, in increments of 5 kW from 5 to 15 kW
- Fast Load Transient Response: Protection from undesired voltage excursions
- Low Ripple and Noise
- Hardware Trigger (Ethernet Option)
- Parallelable up to 75 kW
- Sequencing: Free system controller & speed up test
- Low audible noise
- Water Cooled



83–1875 A



400

480

ETHERNET



LXI RS232

The Sorensen SG series (hereafter SG Series) represents the next generation of high power programmable DC power supplies. The SG Series is designed for exceptional load transient response, low noise and the highest power density in the industry. With a full 15 kW available in a 3u package the SG leads the industry in power density. Water cooling allows for use in applications where the environment precludes the use of air cooled power supplies.

At the heart of the SG series is a 5 kW power module. Depending on the output voltage, one to three modules can be configured in a single chassis to deliver 5 kW to 15 kW of power. Combinations of these chassis can then be easily paralleled to achieve power levels up to 75 kW. Paralleled units operate like one single supply providing total system current.

SGA: Outstanding Value - Analog Control

(Sorensen General purpose Analog) The SGA, with its industry leading price performance, is available for customers requiring simple front panel analog controls or external control. The SGA provides essential features like 10- turn potentiometers for setting voltage and current, 3 ½ digit LED readout plus front panel over-voltage protection (OVP) preview/adjustment and reset.

AMETEK
Programmable Power
9250 Brown Deer Road
San Diego, CA 92121-2267
USA

AMETEK[®]
PROGRAMMABLE POWER

SG Series - Water Cooled : Product Specifications

Common					
Remote Sense	Terminals are provided to sense output voltage at point of load. Maximum line drop 5% of rated voltage per. (Greater line drop is allowed, but output regulation specifications no longer apply).				
Parallel Operation	Up to 5 units may be paralleled for additional current within the power supply single-unit specifications, with exception of the DC output current set accuracy. Additional paralleled SG units will add 0.3% inaccuracy per unit. To parallel more than 5 units, contact factory.				
Series Operation	Up to 2 units (see Output Float Voltage)				
Input					
Nominal Voltage 3 phase, 3 wire + ground	380/400 VAC (operating range 342 - 440 VAC) 440/480 VAC (operating range 396 - 528 VAC)				
Frequency	47 – 63Hz				
Power Factor	0.95 typical, at full-rated load and nominal AC input voltage				
Protection (typical)	½ cycle ride-through on all three phases, 3 cycle ride through on single phase; missing phase shutdown				
Programming & Read-back Specifications (with sense wires used)					
	Programming		Read-Back / Monitoring		
	Accuracy	Resolution	Accuracy	Resolution	
Front panel Display	+/- (0.5%fs + 1 digit)	3.5 digits	+/- (0.5%fs + 1 digit)	3.5 digits	Knob control & Display read-back
Remote Analog Interface	Voltage +/-0.25% of full scale Current 0.8% of full scale	NA	+/-1.0% of full scale	NA	25-pin D-sub connector (0~5 V or 0~10 V)
Remote Digital Interface	Voltage: +/- 0.1% of full scale, Current: +/- 0.4% of full scale	+/-0.002% of full scale	Voltage: +/- 0.1% of full scale Current: +/- 0.4% of full scale	+/-0.002% of full scale	Optional RS-232C, IEEE-488.2 and LXI Compliant 10/100 base-T Ethernet (see Options)
OVP	+/- 1% of full scale	+/-0.002% of full scale			Programming range: 5-110% Configured from front panel, remote analog or via optional digital inputs
User I/O	Disconnect & Polarity-reversal relay control (Only available with Ethernet Option)				Digital 10-pin Molex type connector
Software	IVI & CVI drivers available under SUPPORT at: www.ProgrammablePower.com				
Physical					
Width	19.00 in (48.3 cm)				
Depth	25.95 in (65.9 cm)				
Height	5.22 in (13.3 cm)				
Weight	(5kW) ~ 73 lbs (33.2 kg) (10kW) ~ 85 lbs (38.6 kg) (15kW) ~ 97 lbs (44.0 kg)				
Shipping Weight	Contact factory for more product & shipping weights				

SG Series - Water Cooled

5-75 kW

Output	
Ripple & Noise (Voltage Mode, Typical)	See Output: Voltage & Current Ranges Chart below. Ripple and noise specified at full load, nominal AC input. Noise measured with 6 ft. cable, 1µf at load
Ripple (Current Mode)	< +/- 0.04% of full scale rms current
DC Voltage Slew Rate	< 100 ms 5-95% of full scale typical - resistive load (Contact factory for model specific slew rates)
Line Regulation (with sense wires used)	(±10% of nominal AC input, constant load) Voltage Mode: +/- 0.01% of full scale Current Mode: +/- 0.05% of full scale
Load Regulation (with sense wires used)	(no load to full load, nominal AC input) Voltage Mode: +/- 0.02% of full scale Current Mode: +/- 0.1% of full scale
Load Transient Response	Recovers within 1ms to +/-0.75% of full-scale of steadystate output for a 50% to 100% or 100% to 50% load change
Efficiency	87% typical at nominal line and max load
Stability	±0.05% of set point after 30 minute warm-up and over 8 hours at fixed line, load and temperature, typical
Temperature Coefficient	0.02%/ C of maximum output voltage rating for voltage set point, typical 0.03%/ C of maximum output current rating for current set point, typical
Output Float Voltage	Negative terminal within +/- 300 V of chassis potential. (We recommend the use of optional Isolated Analog Interface (IAI).) Supplies in "series" should be the same output voltage/current, in not system current is limited to lower of the two supplies.

Output: Voltage and Current Ranges					
Power	3U			Ripple & Noise	
	5 kW	10 kW	15 kW	rms (20 Hz-300 kHz)	p-p (20 Hz-20 MHz)
Voltage	Current				
40	125	250	375	20 mV	75 mV
60	83	167	250	20 mV	75 mV

SG Series - Water Cooled - Back Panel

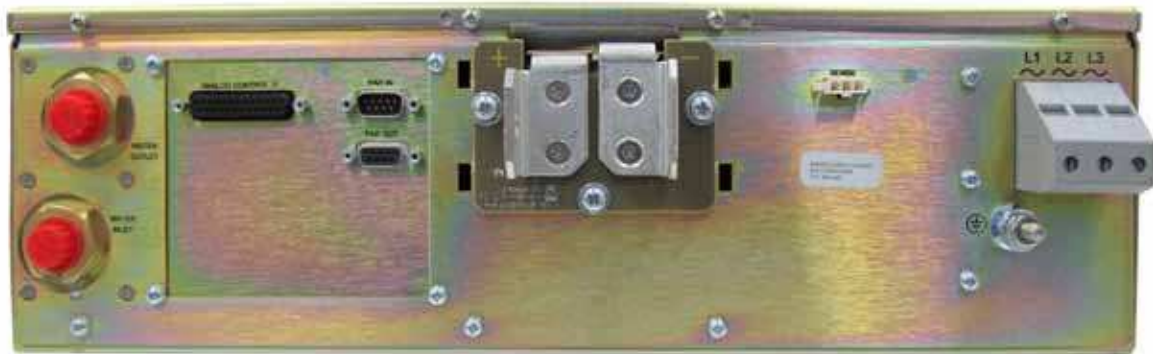

SG Series - Water Cooled : Product Diagram

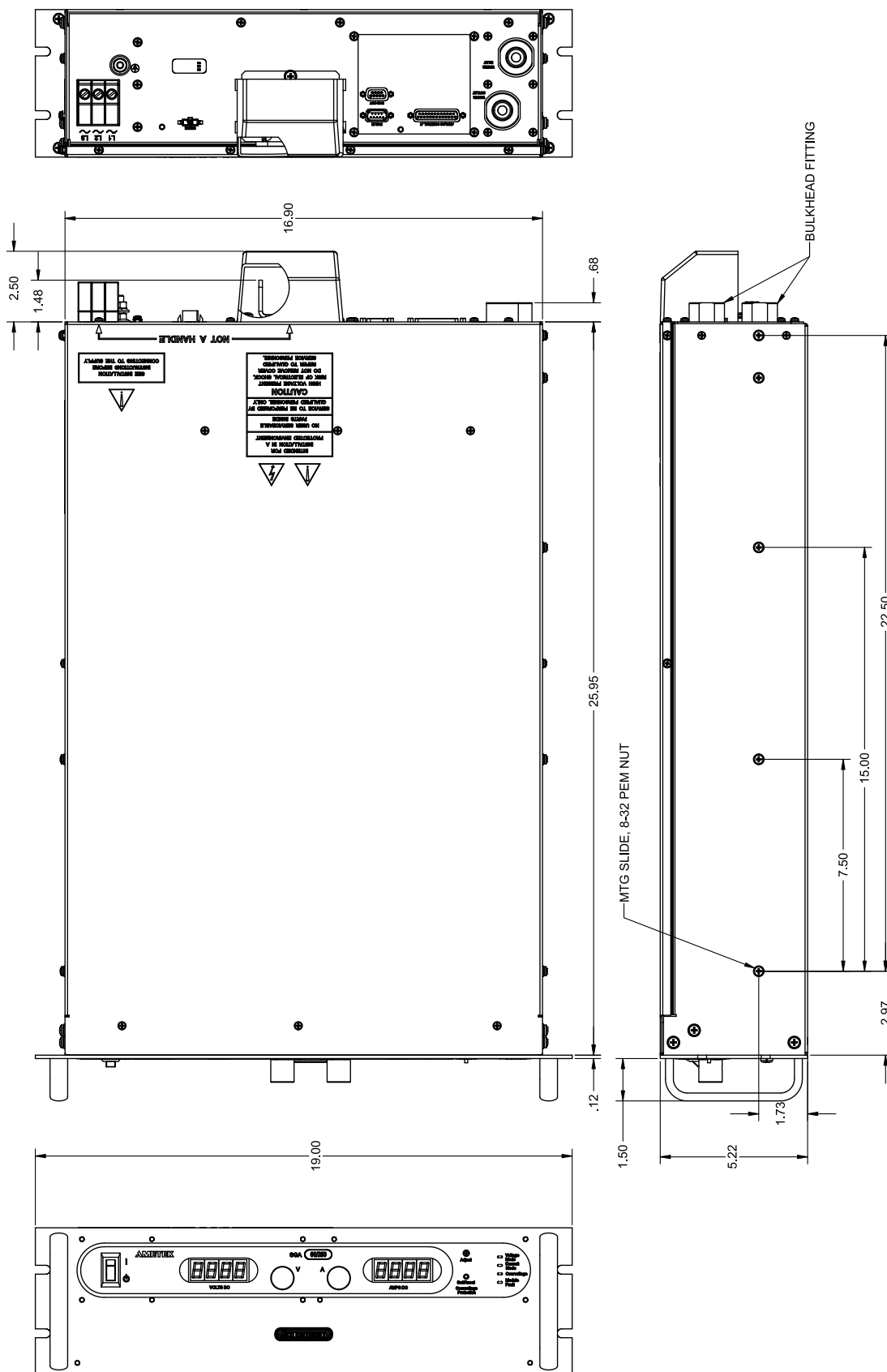

Advanced Power Simulation (with Digital Interface Options)

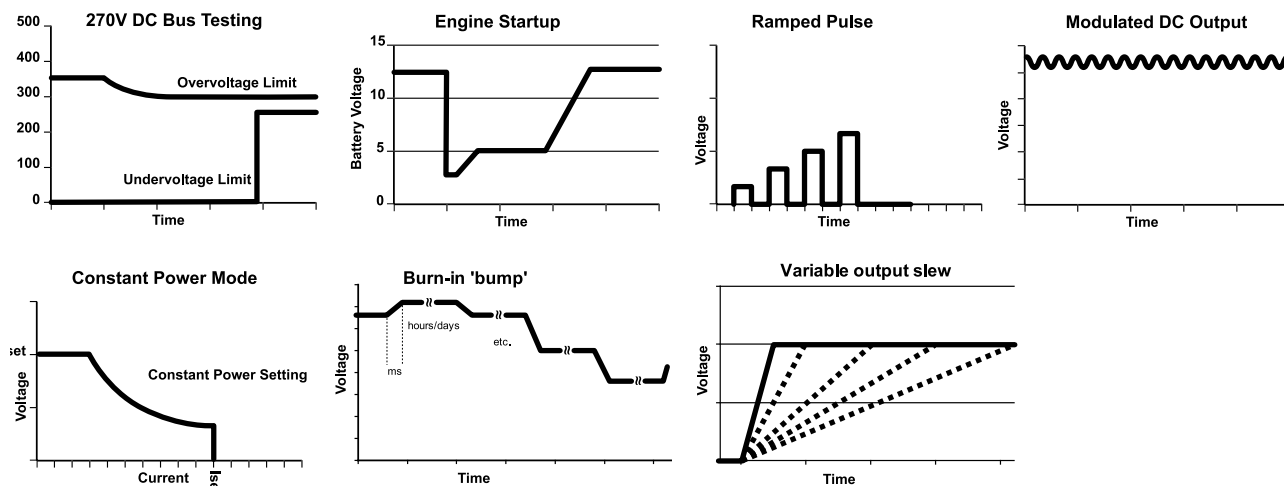

SGI model provides constant power mode allowing independent setting of the max voltage, current and power

SGI / SGA Comparison Chart

Feature	SGA
Modular Design	•
Fast Load Transient	•
Parallelable	•
Analog & Digital Summing	Optional
Direct Front Panel V/I Control	•
3½ Digit LED Readout	•
Sequencing	With optional digital interface
Save/Recall Setups	
System Power Readouts	
Constant Power Mode	
IEEE-488.2/RS-232C	Optional
LXI Class C Ethernet/ RS-232	Optional

Environmental

Operating Temperature	0 to 50° C
Liquid Cooling Temperature	30 ° C Max (Temp vs dew point must prevent condensation)
Coolant Flow Rate	1.25 GPM minimum, 26 GPM maximum
Static Pressure	80 PSI Max
Static Pressure Differential	8 PSI, Typical at 1.5 GPM
Storage Temperature	0° C to 65° C
Humidity Range	Relative humidity up to 95% non-condensing, 0° C – 50° C
Condensation	Internal condensation must be prevented by ensuring that the temperature of the coolant is sufficiently high compared with the ambient air dew point.
Altitude	Operating full power available up to 5,000 ft. (~1,500 m), derate 10% of full power for every 1,000 feet higher; non-operating to 40,000 ft. (~12,000 m)
Cooling	Water or water/ethylene glycol
Regulatory	Certified to UL/CSA 61010 and IEC/EN 61010-1 by a NRTL, CE Compliant, Semi-F47 Compliant. LVD Categories: Installation Category II: Pollution Degree 2; Class II Equipment: for Indoor Use Only. EMC Directive, EN 61326:1998

SG Series - Water Cooled

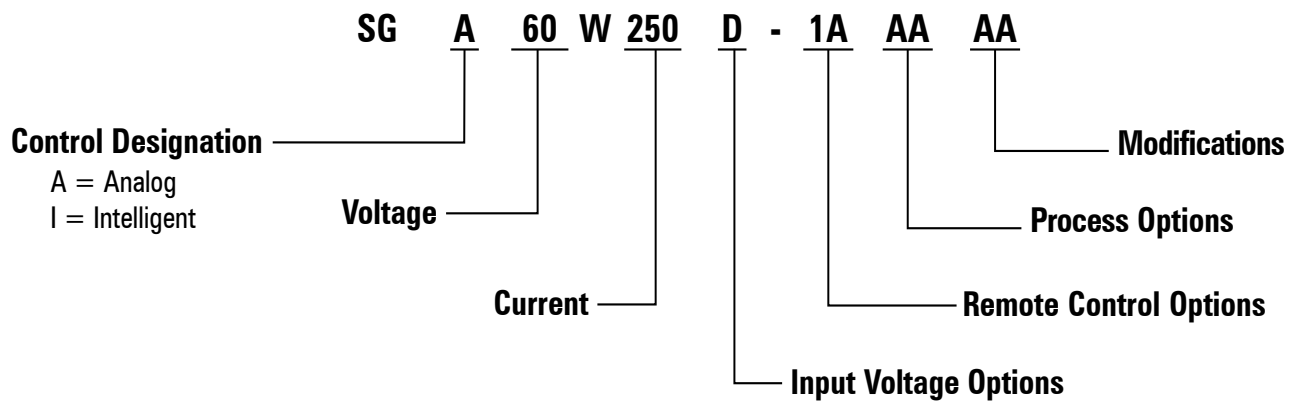

Options and Accessories

Control Options	A: Analog
Input Options	D: Input Voltage 342 / 440VAC, 3 Phase E: Input Voltage 396 / 528VAC, 3 Phase
Remote Control Options	0A: No Option 1A: IEEE-488.2 + RS-232C (Check for availability) 1C: Ethernet + RS-232C (Check for availability) 1D: Isolated Analog Control 1E: Shaft Locks
Process Options	AA: No option AB: Certificate of Calibration (includes Test Data)
Accessories	890-453-03: Paralleling Cable (for up to 5 units, requires one cable per unit placed in parallel)
Contact factory for other combinations	