

EPC1020H & EPC1020H-LF



- Designed for Low Common Mode Noise
- TTL Compatible, Active High, 0.2 mA Max. Enable Current
- 70% Min. Efficiency at Full Load @ Nominal Input Voltage
- Add "-LF" after part number for Lead-Free
- Input Filter to Reduce Input Ripple Current
- Input/Output Isolation : 2000 Vrms

Electrical Specifications

Parameters	Min.	Typ.	Max.	Units
Input Voltage	4.5	12	5.5	Volts
Output Voltage	---	9 ± 5%	---	Volts
Output Current	---	---	250	mA
Output Ripple & Noise @ 20 MHz BW	---	---	100	mV p-p

Package

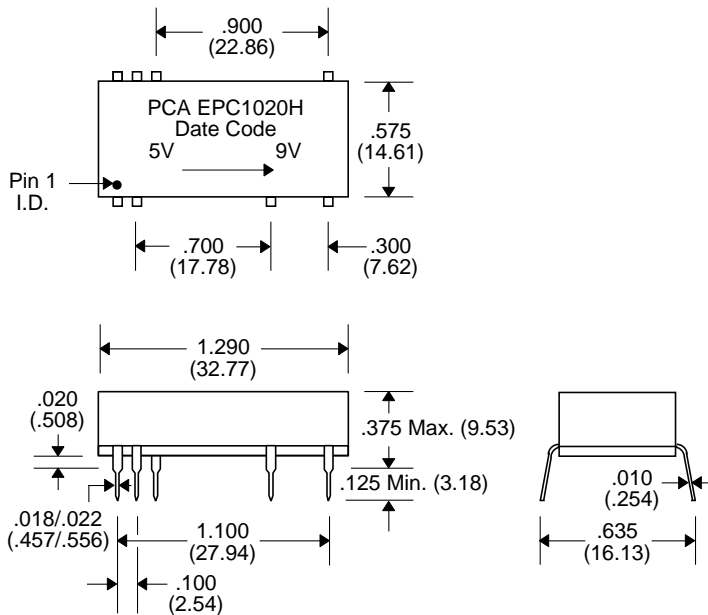

Pin Connections

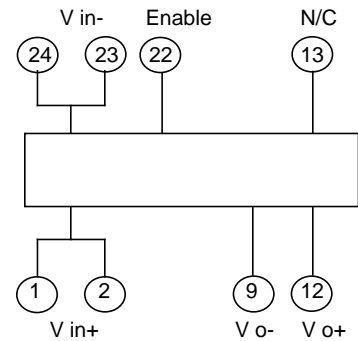

Notes :	EPC1020H	EPC1020H-LF
1. Lead Finish	SnPb	Hot Tin Dip (Sn)
2. Peak Temperature Rating (Wave Solder Process Only)	260°C	260°C
3. Weight	TBD grams	TBD grams
4. Packaging Information (Tube)	TBD pieces/tube	TBD pieces/tube

Unless Otherwise Specified Dimensions are in Inches /mm ± .010 / .25