

# Ethernet DC/DC Converter

## EPC1015H

- Designed for Low Common Mode Noise •
- Output Regulated •
- 70% Efficiency at Full Load @ Nominal Input Voltage •
- Input Filter to Reduce Input Ripple Current •
- Input/Output Isolation : 2000 Vrms •

### Electrical Specifications

Parameters	Min.	Typ.	Max.	Units
Input Voltage	4.5	5.0	5.5	Volts
Output Voltage	---	9 ± 5%	---	Volts
Output Current	---	---	200	mA
Output Ripple & Noise @ 20 MHz BW	---	---	100	mV p-p
---	---	---	---	---

### Pin Connections

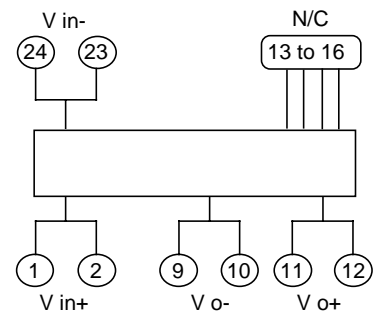

### Package E

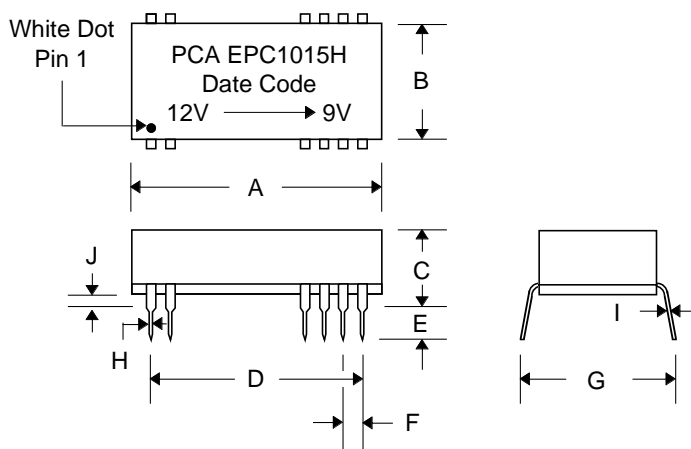

### Dimensions

Dim.	(Inches)			(millimeters)		
	Min.	Max.	Nom.	Min.	Max.	Nom.
A	1.280	1.300	1.290	32.51	33.02	32.77
B	.565	.585	.575	14.35	14.86	14.61
C	---	.375	---	---	9.53	---
D	---	---	1.100	---	---	27.94
E	.125	---	---	3.18	---	---
F	---	---	.100	---	---	2.54
G	---	---	.635	---	---	16.13
H	.018	.022	.020	.457	.556	.508
I	.008	.012	.010	.203	.305	.254
J	---	---	.020	---	---	.508