

SMD 14 Pin 5 Tap TTL Compatible Active Delay Lines

Delays are $\pm 5\%$ or ± 2 nS Tap		SMD Part Number	Delays are $\pm 5\%$ or ± 2 nS Tap		SMD Part Number
	Total			Total	
5, 10, 15, 20	25	EPA2398-25	80, 160, 240, 320	400	EPA2398-400
6, 12, 18, 24	30	EPA2398-30	84, 168, 252, 336	420	EPA2398-420
7, 14, 21, 28	35	EPA2398-35	88, 176, 264, 352	440	EPA2398-440
8, 16, 24, 32	40	EPA2398-40	90, 180, 270, 360	450	EPA2398-450
9, 18, 27, 36	45	EPA2398-45	94, 188, 282, 376	470	EPA2398-470
10, 20, 30, 40	50	EPA2398-50	100, 200, 300, 400	500	EPA2398-500
12, 24, 36, 48	60	EPA2398-60	110, 220, 330, 440	550	EPA2398-550
15, 30, 45, 60	75	EPA2398-75	120, 240, 360, 480	600	EPA2398-600
20, 40, 60, 80	100	EPA2398-100	130, 260, 390, 520	650	EPA2398-650
25, 50, 75, 100	125	EPA2398-125	140, 280, 420, 560	700	EPA2398-700
30, 60, 90, 120	150	EPA2398-150	150, 300, 450, 600	750	EPA2398-750
35, 70, 105, 140	175	EPA2398-175	160, 320, 480, 640	800	EPA2398-800
40, 80, 120, 160	200	EPA2398-200	170, 340, 510, 680	850	EPA2398-850
45, 90, 135, 180	225	EPA2398-225	180, 360, 540, 720	900	EPA2398-900
50, 100, 150, 200	250	EPA2398-250	190, 380, 570, 760	950	EPA2398-950
60, 120, 180, 240	300	EPA2398-300	200, 400, 600, 800	1000	EPA2398-1000
70, 140, 210, 280	350	EPA2398-350			

Delay times referenced from input to leading edges at 25°C, 5.0V, with no load.

DC Electrical Characteristics			Min	Max	Unit
Parameter	Test Conditions				
V _{OH}	High-Level Output Voltage	V _{CC} = min. V _{IL} = max. I _{OH} = max	2.7		V
V _{OL}	Low-Level Output Voltage	V _{CC} = min. V _{IH} = min. I _{OL} = max		0.5	V
V _{IK}	Input Clamp Voltage	V _{CC} = min. I _I = I _{IK}		-1.2	V
I _{IH}	High-Level Input Current	V _{CC} = max. V _{IN} = 2.7V		50	μA
		V _{CC} = max. V _{IN} = 5.25V		1.0	mA
I _{IL}	Low-Level Input Current	V _{CC} = max. V _{IN} = 0.5V		-2	mA
I _{OS}	Short Circuit Output Current	V _{CC} = max. V _{OUT} = 0. (One output at a time)	-40	-100	mA
I _{CCH}	High-Level Supply Current	V _{CC} = max. V _{IN} = OPEN		75	mA
I _{CCL}	Low-Level Supply Current	V _{CC} = max. V _{IN} = 0		75	mA
T _{RO}	Output Rise Time	T _d ≤ 500 nS (0.75 to 2.4 Volts)		4	nS
		T _d > 500 nS		5	nS
N _H	Fanout High-Level Output	V _{CC} = max. V _{OH} = 2.7V		20 TTL LOAD	
N _L	Fanout Low-Level Output	V _{CC} = max. V _{OL} = 0.5V		10 TTL LOAD	

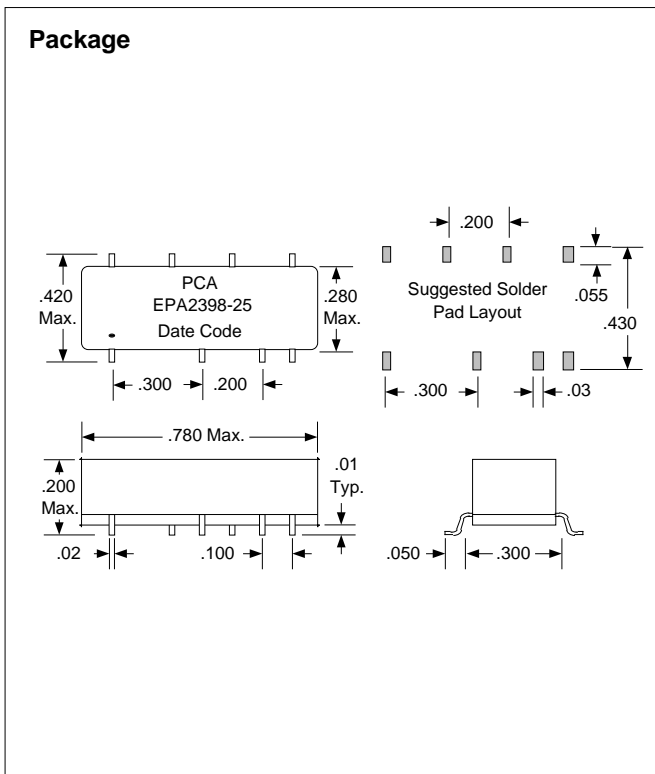
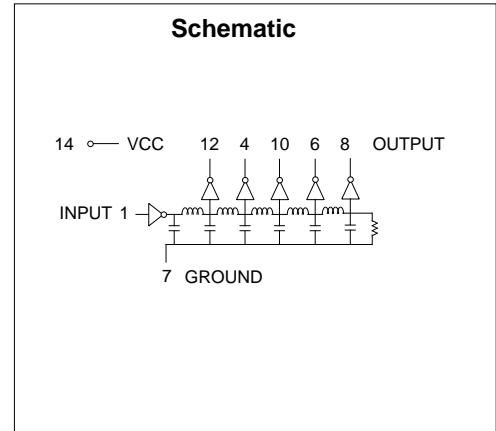

Recommended Operating Conditions		Min	Max	Unit
V _{CC}	Supply Voltage	4.75	5.25	V
V _{IH}	High-Level Input Voltage	2.0		V
V _{IL}	Low-Level Input Voltage		0.8	V
I _{IK}	Input Clamp Current		-18	mA
I _{OH}	High-Level Output Current		-1.0	mA
I _{OL}	Low-Level Output Current		20	mA
PW*	Pulse Width of Total Delay	40		%
d*	Duty Cycle		40	%
T _A	Operating Free-Air Temperature	0	+70	°C

*These two values are inter-dependent.

Input Pulse Test Conditions @ 25° C		Unit
E _{IN}	Pulse Input Voltage	3.2 Volts
PW	Pulse Width % of Total Delay	50 %
T _{RI}	Pulse Rise Time (0.75 - 2.4 Volts)	2.0 nS
PRR	Pulse Repetition Rate @ T _d ≤ 200 nS	5.0 MHz
	Pulse Repetition Rate @ T _d > 200 nS	100 KHz
V _{CC}	Supply Voltage	5.0 Volts



1799 SCHOENBORN ST.
NORTH HILLS, CA 91343
TEL: (818) 892-0761
FAX: (818) 894-5791