

14 Pin DIL 5 Tap Low Profile TTL Compatible MIL 883 Active Delay Lines

TAP DELAYS ±5% or ±2 nS	TOTAL DELAYS ±5% or ±2 nS	PART NUMBER	TAP DELAYS ±5% or ±2 nS	TOTAL DELAYS ±5% or ±2 nS	PART NUMBER
5, 10, 15, 20	25	EP9590-25	40, 80, 120, 160	200	EP9590-200
6, 12, 18, 24	30	EP9590-30	45, 90, 135, 180	225	EP9590-225
7, 14, 21, 28	35	EP9590-35	50, 100, 150, 200	250	EP9590-250
8, 16, 24, 32	40	EP9590-40	60, 120, 180, 240	300	EP9590-300
9, 18, 27, 36	45	EP9590-45	70, 140, 210, 280	250	EP9590-280
10, 20, 30, 40	50	EP9590-50	80, 160, 240, 320	400	EP9590-400
12, 24, 36, 48	60	EP9590-60	84, 168, 252, 336	420	EP9590-420
15, 30, 45, 60	75	EP9590-75	88, 176, 264, 352	440	EP9590-440
20, 40, 60, 80	100	EP9590-100	90, 180, 270, 360	450	EP9590-450
25, 50, 75, 100	125	EP9590-125	94, 188, 282, 376	470	EP9590-470
30, 60, 90, 120	150	EP9590-150	100, 200, 300, 400	500	EP9590-500
35, 70, 105, 140	175	EP9590-175			

Delay Times referenced from input to leading edges at 25°C, 5.0V, with no load.

DC Electrical Characteristics		Test Conditions	Min	Max	Unit
Parameter					
V _{OH}	High-Level Output Voltage	V _{CC} = min. V _{IL} = max. I _{OH} = max	2.7		V
V _{OL}	Low-Level Output Voltage	V _{CC} = min. V _{IH} = min. I _{OL} = max		0.5	V
V _{IK}	Input Clamp Voltage	V _{CC} = min. I _I = I _{IK}		-1.2	V
I _{IH}	High-Level Input Current	V _{CC} = max. V _{IN} = 2.7V		50	µA
		V _{CC} = max. V _{IN} = 5.25V		1.0	mA
I _{IL}	Low-Level Input Current	V _{CC} = max. V _{IN} = 0.5V		-2	mA
I _{OS}	Short Circuit Output Current	V _{CC} = max. V _{OUT} = 0. (One output at a time)	-40	-100	mA
I _{CCH}	High-Level Supply Current	V _{CC} = max. V _{IN} = OPEN		75	mA
I _{CCL}	Low-Level Supply Current	V _{CC} = max. V _{IN} = 0		75	mA
T _{RO}	Output Rise Time	T _d ≤ 500 nS (0.75 to 2.4 Volts)		4	nS
N _H	Fanout High-Level Output	V _{CC} = max. V _{OH} = 2.7V		20 TTL LOAD	
N _L	Fanout Low-Level Output	V _{CC} = max. V _{OL} = 0.5V		10 TTL LOAD	

Schematic

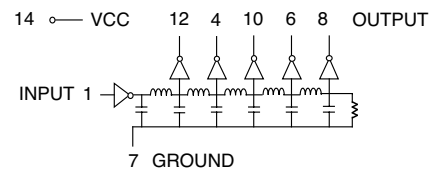

Recommended Operating Conditions		Min	Max	Unit
V _{CC}	Supply Voltage	4.5	5.5	V
V _{IH}	High-Level Input Voltage	2.0		V
V _{IL}	Low-Level Input Voltage		0.8	V
I _{IK}	Input Clamp Current		-18	mA
I _{OH}	High-Level Output Current		-1.0	mA
I _{OL}	Low-Level Output Current		20	mA
PW*	Pulse Width of Total Delay	40		%
d*	Duty Cycle		40	%
T _A	Operating Free-Air Temperature	-55	+125	°C

*These two values are inter-dependent.

Input Pulse Test Conditions @ 25° C		Unit	
E _{IN}	Pulse Input Voltage	3.2	Volts
PW	Pulse Width % of Total Delay	110	%
T _{RI}	Pulse Rise Time (0.75 - 2.4 Volts)	2.0	nS
PRR	Pulse Repetition Rate @ T _d ≤ 200 nS	1.0	MHz
	Pulse Repetition Rate @ T _d > 200 nS	100	KHz
V _{CC}	Supply Voltage	5.0	Volts

Package Dimensions

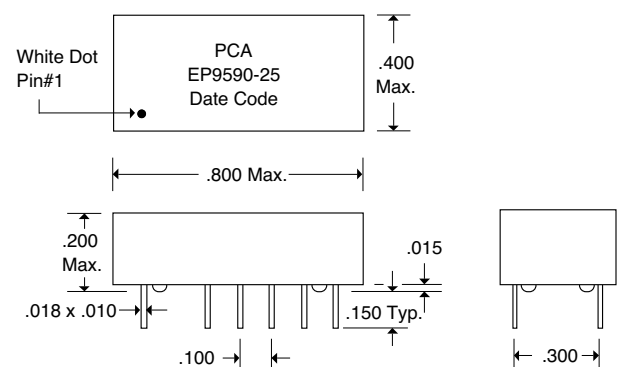

16799 SCHOENBORN ST.
NORTH HILLS, CA 91343
TEL: (818) 892-0761
FAX: (818) 894-5791