

## EP123XXX & EP123XXX-RC

Add "-RC" after part number for RoHS Compliant

PCA Part Number	Zo Ω (± 10%)	Delays (nS)	Rise Time (nS Max.) [Calculated]	DCR (Ω Max.)	PCA Part Number	Zo Ω (± 10%)	Delays (nS)	Rise Time (nS Max.) [Calculated]	DCR (Ω Max.)
EP123101(-RC)	100	0.0 ± 0.25	1.0	1.0	EP123119(-RC)	100	9.0 ± 0.25	1.9	1.0
EP123102(-RC)	100	0.5 ± 0.25	1.0	1.0	EP123120(-RC)	100	9.5 ± 0.25	2.0	1.0
EP123103(-RC)	100	1.0 ± 0.25	1.0	1.0	EP123121(-RC)	100	10.0 ± 0.25	2.0	1.0
EP123104(-RC)	100	1.5 ± 0.25	1.0	1.0	EP123123(-RC)	100	11.0 ± 0.25	2.2	2.0
EP123105(-RC)	100	2.0 ± 0.25	1.0	1.0	EP123125(-RC)	100	12.0 ± 0.25	2.3	2.0
EP123106(-RC)	100	2.5 ± 0.25	1.0	1.0	EP123127(-RC)	100	13.0 ± 0.25	2.5	2.0
EP123107(-RC)	100	3.0 ± 0.25	1.0	1.0	EP123129(-RC)	100	14.0 ± 0.25	2.6	2.0
EP123108(-RC)	100	3.5 ± 0.25	1.0	1.0	EP123131(-RC)	100	15.0 ± 0.25	2.8	2.0
EP123109(-RC)	100	4.0 ± 0.25	1.0	1.0	EP123133(-RC)	100	16.0 ± 0.25	3.0	2.5
EP123110(-RC)	100	4.5 ± 0.25	1.0	1.0	EP123135(-RC)	100	17.0 ± 0.25	3.2	2.5
EP123111(-RC)	100	5.0 ± 0.25	1.1	1.0	EP123137(-RC)	100	18.0 ± 0.25	3.4	2.5
EP123112(-RC)	100	5.5 ± 0.25	1.2	1.0	EP123139(-RC)	100	19.0 ± 0.25	3.6	2.5
EP123113(-RC)	100	6.0 ± 0.25	1.3	1.0	EP123141(-RC)	100	20.0 ± 0.50	3.8	2.5
EP123114(-RC)	100	6.5 ± 0.25	1.4	1.0	EP123146(-RC)	100	25.0 ± 0.50	4.5	4.0
EP123115(-RC)	100	7.0 ± 0.25	1.5	1.0	EP123151(-RC)	100	30.0 ± 0.50	5.5	4.5
EP123116(-RC)	100	7.5 ± 0.25	1.6	1.0	EP123156(-RC)	100	35.0 ± 0.50	6.4	5.5
EP123117(-RC)	100	8.0 ± 0.25	1.7	1.0	EP123161(-RC)	100	40.0 ± 0.50	7.4	6.0
EP123118(-RC)	100	8.5 ± 0.25	1.8	1.0	EPA594(-RC)	100	45.0 ± 1.00	8.0	6.5

DC Electrical Characteristics	Min.	Max.	Unit
Distortion	---	± 10	%
Temperature Coefficient of Delay	---	100	PPM/°C
Insulation Resistance @ 100 Vdc	1000	---	Meg Ω
Dielectric Strength	---	100	Vdc

### Schematic

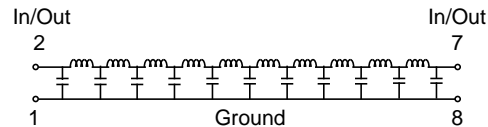

Recommended Operating Conditions	Min.	Max.	Unit
P <sub>VW</sub> *	Pulse Width % of Total Delay	200	%
D*	Duty Cycle	40	%
T <sub>A</sub>	Operating Free-Air Temperature	0	+70 °C

\*These two values are inter-dependent.

### Package

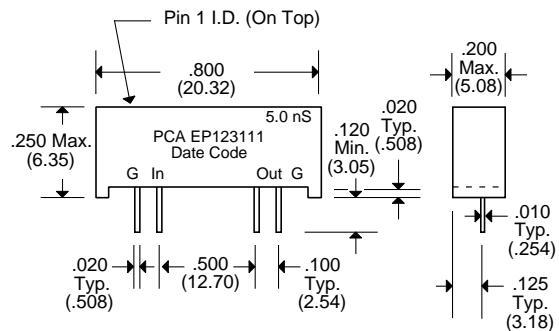

Input Pulse Test Conditions @ 25° C	Unit	
V <sub>IN</sub>	Pulse Input Voltage	3.0 Volts
P <sub>W</sub>	Pulse Width % of Total Delay	300 %
T <sub>RI</sub>	Input Rise Time (10-90%)	2.0 nS
P <sub>RR</sub>	Pulse Repetition Rate @ T <sub>d</sub> ≤ 150 nS	1.0 MHz
	Pulse Repetition Rate @ T <sub>d</sub> > 150 nS	300 KHz

Notes :	EP123XXX	EP123XXX-RC
1. Lead Finish	SnPb	Hot Tin Dip (Sn)
2. Peak Temperature Rating (Wave Solder Process Only)	260°C	260°C
4. Weight	0.9 grams	0.9 grams
5. Packaging Information (Tube)	TBD pieces/tube	TBD pieces/tube

Unless Otherwise Specified Dimensions are in Inches /mm ± .010 / .25