



- Noise Suppression Choke
- 5 A Max. Rated Current
- 250 Vrms Isolation

### Electrical Parameters @ 25° C

Inductance ( $\mu\text{H} \pm 30\%$ )	Impedance ( $\Omega$ Min. )	DCR ( $\text{m}\Omega$ Max.)	Turns Ratio	SRF (MHz Typ. )
	@100 MHz			
1.5	600	11	1 : 1	80
Pins 1-4, 2-3	Pins 1-4, 2-3	Pins 1-4, 2-3	Pins 1-4 : 2-3	

### Schematic

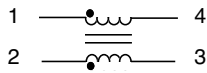

### Impedance Curve

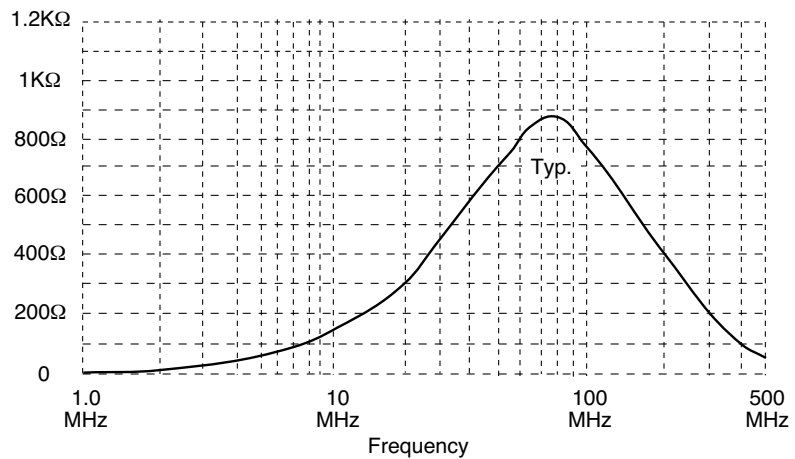

### Package

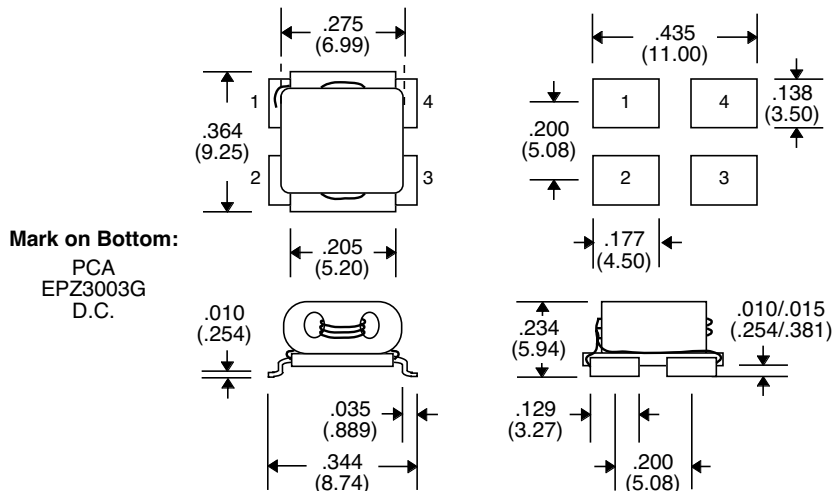

Unless Otherwise Specified Dimensions are in Inches /mm  $\pm .010 / .25$