

Power Choke

EPZ3002G



- Noise Suppression Choke
- UL94V-0 Recognized Components
- UL1446 Class B Insulation Systems
- 2.5 A Max. Rated Current
- 10K PERM Materials
- 500 Vrms Isolation

Electrical Parameters @ 25° C

Inductance (mH ± 30%)	DCR (mΩ Max.)	Turns Ratio	SRF (MHz Typ.)	Temp. Rise @ 2.5 A (°C Typ.)
@10 KHz, 0.1 Vrms	Matched with ± 5%			
3.0	80	1 : 1	1.5	37
Pins 1-2, 3-4	Pins 1-2, 3-4	Pins 1-2 : 3-4		

Schematic

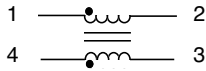

Impedance (mp)

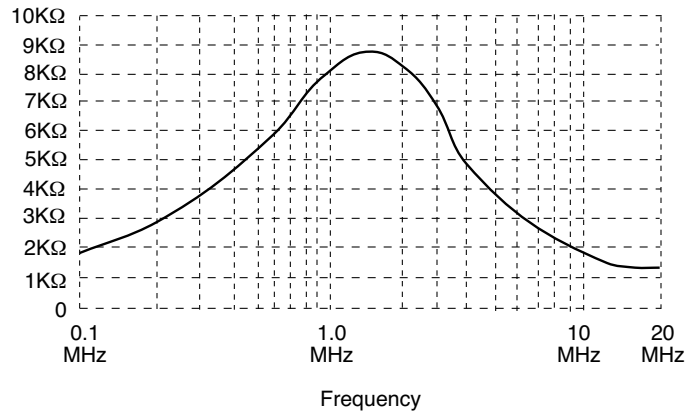

Package

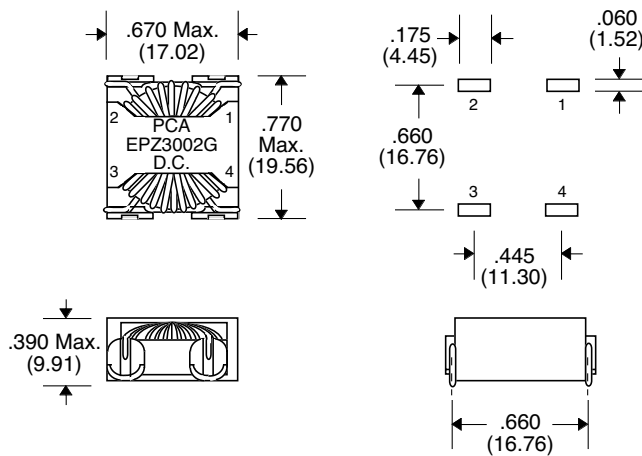

Unless Otherwise Specified Dimensions are in Inches /mm ± .010 / .25