

Flyback Power Transformer

EPC3127-X & EPC3127-X-LF



- Used in SMPS Flyback Topology
- Designed for use with Power Integration Chip
- Reinforced Insulation (Triple Insulated Wire)
- Add “-LF” after part number for Lead-Free
- UL 94V-0 Recognized Components
- UL 1446 Class F Insulation System
- Very Low Core Loss

Electrical Parameters @ 25° C

PCA Part Number	Chipset	Voltage (Vdc)				L Prim. [Pins 2-1] ($\mu\text{H} \pm 10\%$) @ 10 KHz, 0.1 Vrms	Current (A dc)			Schematic
		V In	V Out 1	V Out 2	Fb		V Out 1	V Out 2	Fb	
EPC3127-1(-LF)	TNY268P	120-375	5	---	15	1900	3.0	---	.05	A
	TNY266P	120-375	5	---	15	1900	2.0	---	.05	A
EPC3127-2(-LF)	TOP232Y/TOP242Y	120-375	5	3.3	15	2400	2.0	2	.05	B
EPC3127-3(-LF)	TOP244P	120-375	13.55	---	15	475	1.2	---	.05	A
EPC3127-4(-LF)	TNY267	120-375	3.3	---	15	2800	2.0	---	.05	A

• Switching Frequency : 132 KHz • Isolation : 4500 Vrms •

Dielectric Rating (Vrms)		
1 sec. 4500 or 60 sec. 3750	1 sec. 4500 or 60 sec. 3750	1 sec. 1500
V In Wdg to all V Out Wdg's & Core	Between V Out Wdg's to Core	Between V In Wdg & Fb Wdg

Notes :	EPC3127-X	EPC3127-X-LF
1. Lead Finish	SnPb	Hot Tin Dip (Sn)
2. Peak Solder Rating (Wave Solder Only)	260°C 10 (+2/-0) seconds	260°C 10 (+2/-0) seconds
3. Weight	TBD grams	TBD grams
4. Packaging Information Tray :	TBD pieces/tray	TBD pieces/tray

Schematic A

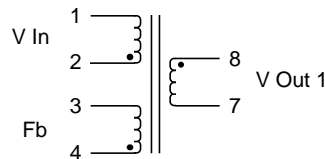

Schematic B

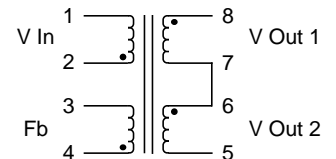

Package

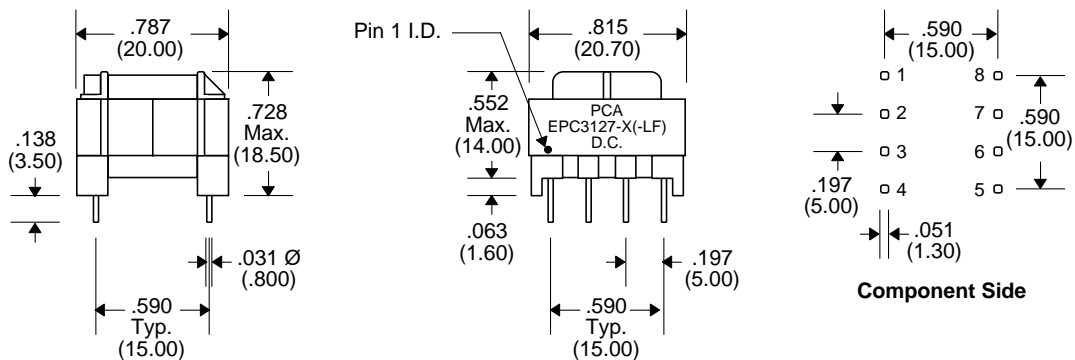

Unless Otherwise Specified Dimensions are in Inches /mm $\pm .010 / .25$