

EPC3108G-XXX



- Designed for Switching Supply-Current Sense Applications
- Optimal Performance at 250 KHz and above
- Operating Temperature : -25°C to +105°C
- UL1446 Class B Insulating System
- Class B 130°C Insulation System
- UL94V0 Recognized Materials

Electrical Parameters @ 25° C

PCA Part Number	Turns Ratio (Pri. to Sec.)	Inductance (µH Min.) @ 10 KHz	Secondary DCR (Ω Max.)	Primary (Amps Max.)	Insulation Resistance (meg Ω Min.)	Vt (V-µSec. Max.)
EPC3108G-125	1:125	3000	7.70	6.0	10	92.5
EPC3108G-100	1:100	2000	6.20	6.0	10	75.0
EPC3108G-85	1:85	1430	5.30	6.0	10	62.5
EPC3108G-70	1:70	980	4.75	6.0	10	52.5
EPC3108G-50	1:50	500	2.50	6.0	10	27.5
EPC3108G-40	1:40	320	1.35	6.0	10	30.0
EPC3108G-30	1:30	180	1.00	6.0	10	22.5

• Note : Clamp cover is optional •

Package

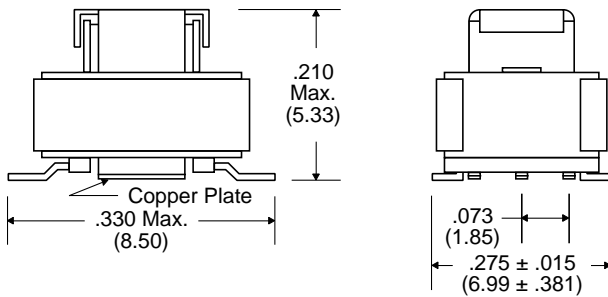

Application Circuit

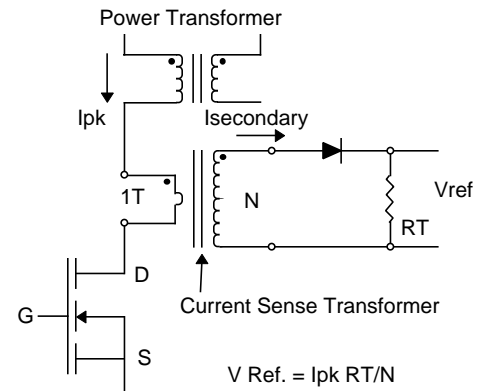

Recommended Pad Layout

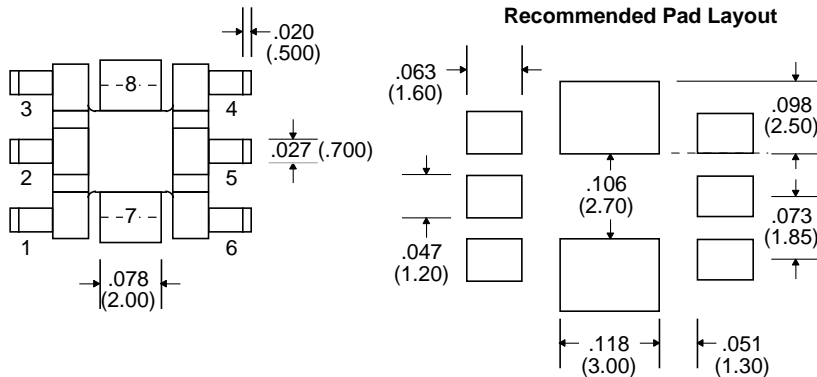

Schematic

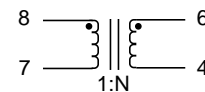

Unless Otherwise Specified Dimensions are in Inches /mm ± .010 / .25