

EPG4004F & EPG4004F-RC

- Complies with or exceeds IEEE 802.3ab 1000Base-T
- Guaranteed to operate with 10/100Base-TX
- 1500 Vrms Isolation
- RoHS Compliant

Electrical Parameters @ 25° C

OCL (μ H Min.)	Insertion Loss (dB Max.)			Return Loss (dB Min.)				CMRR (dB Min.)	Common to Differential (dB Min.)				Cross talk (dB Min.)		
	@ 100 KHz, 0.1 Vrms 8 mA DC bias	1-65 MHz	65-100 MHz	100-125 MHz	1-40 MHz	60 MHz	80 MHz		100 MHz	1-80 MHz	1 MHz	30 MHz	50 MHz	100 MHz	1-40 MHz
350 (Media Side)	-1	-1.1	-1.5	-18	-15	-12	-10	-30	-60	-40	-35	-30	-40	-35	-30

• Rise Time : 1.75 nS Max. • Impedance : 100 Ω •

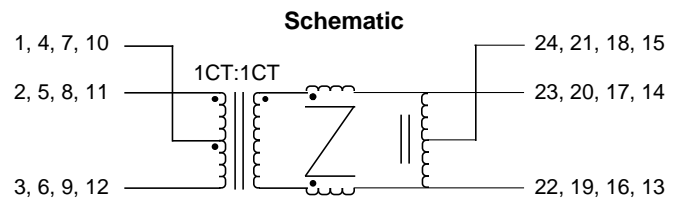
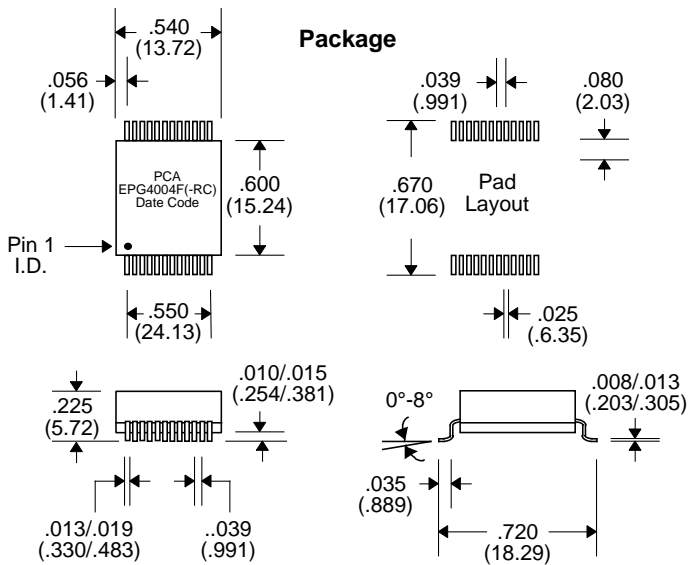

Notes :	EPG4004F	EPG4004F-RC
1. Assembly Process (Solder Composition)	(Leadframe) SnPb	Sn
	(Assembly Solder) SnPb	SnPb (RoHS exemption 7a)
2. Peak Solder Rating (per IPC/JEDEC J-STD-020C)	225°C	260°C
3. Moisture Sensitive Levels (MSL) (per IPC/JEDEC J-STD-020C)	3 (168 Hours, \leq 30°C/60%RH)	4 (72 Hours, \leq 30°C/60%RH)
4. Weight	5.6 grams	5.6 grams
5. Packaging Information	(Tube) 18 pieces/tube	18 pieces/tube
	(Tape & Reel) 350 pieces/13" reel (*EPG4004F-TR)	350 pieces/13 reel (*EPG4004F-RCTR)

Unless Otherwise Specified Dimensions are in Inches /mm \pm .010 / .25