



- Robust construction allows for toughest soldering processes
- Guaranteed to operate with 8 mA DC bias
- Complies with or exceeds IEEE 802.3, 10/100Base-TX Standards
- Lead-Free
- Open Type (No-outside winding lead)
- Operating Temperature : -40°C to +85°C
- Wire Insulation Class : MW 83C
- 1500 Vrms Isolation for 1 min. or 1800Vrms for 1 sec.

Electrical Parameters @ 25° C

OCL	Insertion Loss (dB Max.)	Return Loss (dB Min.)				CMRR (dB Min.)	DCMR (dB Min.)	Crosstalk (dB Min.) Between Channels
		0.5-30 MHz	30-45 MHz	45-60 MHz	60-80 MHz			
100 KHz, 0.1 Vrms 8 mA DC Bias	0.5-100 MHz	0.5-30 MHz	30-45 MHz	45-60 MHz	60-80 MHz	0.5-100 MHz	0.5-100 MHz	1-100 MHz
Pin16-14/Pin11-9	Xmit/Rcv	Xmit/Rcv	Xmit/Rcv	Xmit/Rcv	Xmit/Rcv	Xmit/Rcv	Xmit/Rcv	
350 μH	-1.1/-1.1	-18/-18	-16/-16	-14/-14	-12/-12	-24/-24	-30/-30	-35

• Impedance : 100 Ω Xmit / 100 Ω Rcv • Rise Time : 3.0 nS Max. •

Package

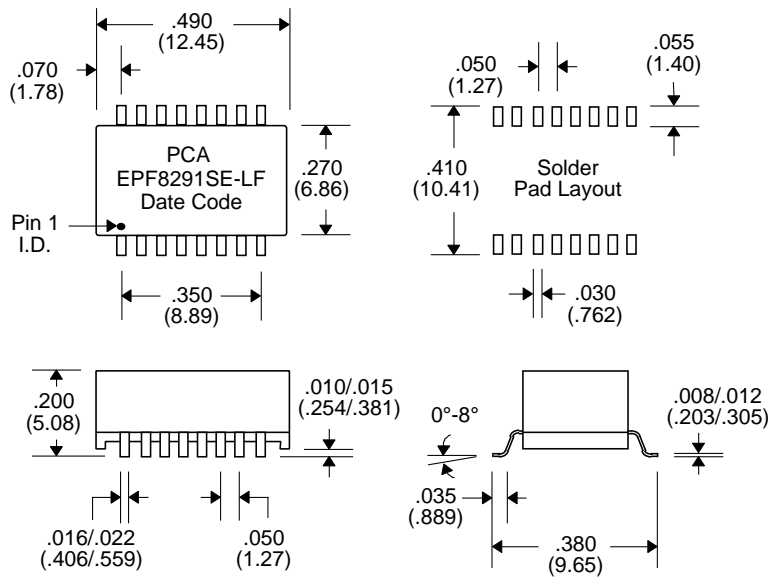

Schematic

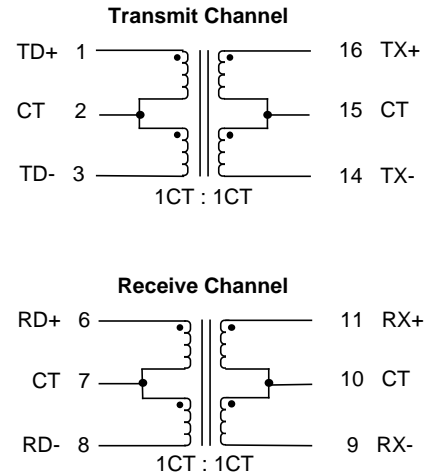

Notes :	EPF8291SE-LF
1. Lead Finish	Hot Tin Dip (Sn) †
2. Peak Temperature Rating	245°C
3. Moisture Sensitive Levels	MSL = 1
4. Weight	TBD gram
5. Packaging Information (Tube)	40 pieces/tube
(Tape & Reel)	650 pieces/13" reel

† Lead Material : Ni Barrier over Cu

Unless Otherwise Specified Dimensions are in Inches /mm ± .010 / .25