

10/100Base-TX Interface Module for NIC/HUB Applications

EPF8264G & EPF8264G-RC

- Robust construction allows for toughest soldering processes
- Complies with or exceeds IEEE 802.3, 10/100Base-TX Standards
- Guaranteed to operate with 8 mA DC bias at 105°C
- Add “-RC” after part number for RoHS Compliant
- Operating Temperature : -25°C to +105°C
- Storage Temperature : -25°C to +125°C
- Wire Insulation Class : MW 83C
- 1500 Vrms Isolation

Electrical Parameters @ 25° C

OCL (μ H)	Insertion Loss (dB Max.)			Return Loss (dB Min.)			Common Mode Rejection (dB Min.)			Crosstalk (dB Min.) Between Channels	
	100 KHz, 0.1 Vrms 8 mA DC Bias	1-80 MHz	@ 100 MHz	1-30 MHz	30-60 MHz	60-100 MHz	1-30 MHz	@ 100 MHz	@ 500 MHz	1-10 MHz	10-100 MHz
Cable Side	Xmit/Rcv	Xmit/Rcv	Xmit/Rcv	Xmit/Rcv	Xmit/Rcv	Xmit/Rcv	Xmit/Rcv	Xmit/Rcv	Xmit/Rcv		
350	-1/-1	-1.5/-1.5	-18/-18	-12/-12	-10/-10	-59/-59	-30/-30	-10/-10	-40	-35	

• Impedance : 100 Ω Xmit / 100 Ω Rcv • Rise Time : 3.0 nS Max. •

Package

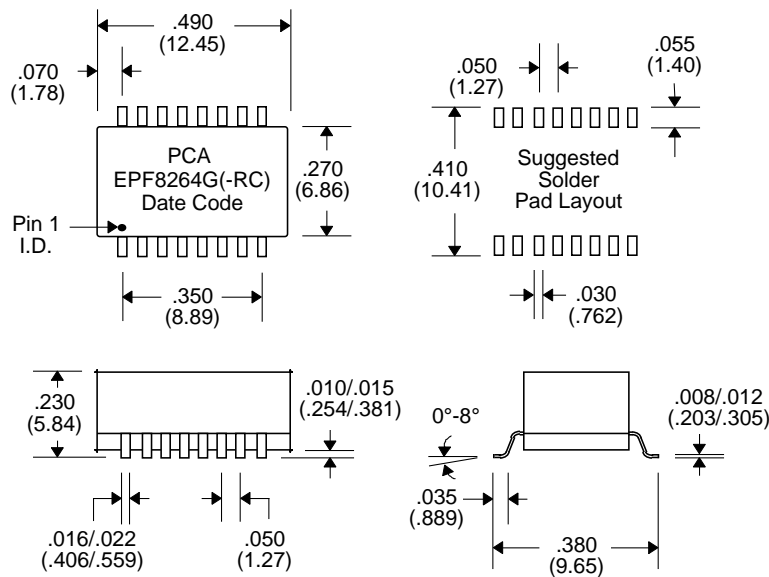

Schematic

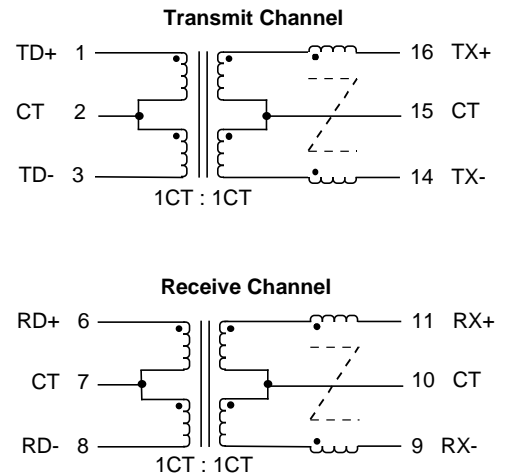

Notes :	EPF8264G	EPF8264G-RC
1. Lead Finish	SnPb	Hot Tin Dip (Sn) †
2. Peak Temperature Rating	225°C	245°C
3. Moisture Sensitive Levels	MSL = 3 (168 Hours, \leq 30°C/60%RH)	MSL = 4 (72 Hours, \leq 30°C/60%RH)
4. Weight	1.0 gram	1.0 gram
5. Packaging Information	(Tube)	40 pieces/tube
	(Tape & Reel)	650 pieces/13" reel

† Lead Material : Ni Barrier over Cu

Unless Otherwise Specified Dimensions are in Inches /mm \pm .010 / .25