

10Base-T Interface Module with all Resistors Integrated EPE6150G

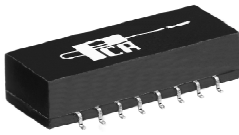

- Optimized for AMD/PHY Controllers
- Robust construction allows for toughest reflow processing
- Complies with or exceeds IEEE 802.3, 10Base-T Standards

Electrical Parameters @ 25° C

Cut-Off Frequency (MHz)	Insertion Loss (dB Max.)	Return Loss (dB Min.)	Attenuation (dB Min.)				Common Mode Rejection (dB Min.)			Crosstalk (dB Min.)
			@ 20 MHz	@ 25 MHz	@ 30 MHz	@ 40 MHz	@ 50 MHz	@ 100 MHz	@ 200 MHz	
± 1.0 MHz	1-10 MHz	5-10 MHz	@ 20 MHz	@ 25 MHz	@ 30 MHz	@ 40 MHz	@ 50 MHz	@ 100 MHz	@ 200 MHz	1-10 MHz
Xmit/Rcv	Xmit/Rcv	Xmit/Rcv	Xmit/Rcv	Xmit/Rcv	Xmit/Rcv	Xmit/Rcv	Xmit/Rcv	Xmit/Rcv	Xmit/Rcv	Xmit/Rcv
17/17	-1/-1	-15/-15	-7/-5	-18/-11	-30/-18	-35/-26	-45/-45	-30/-30	-20/-20	-35/-35

• Isolation : Meets or exceeds 802.3 IEEE Requirements • Characteristic Filter Impedance : 100 Ω •

Schematic

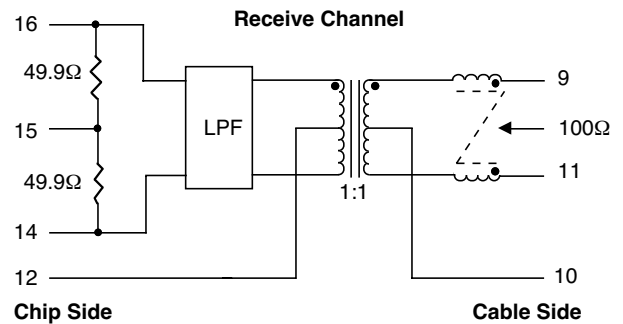
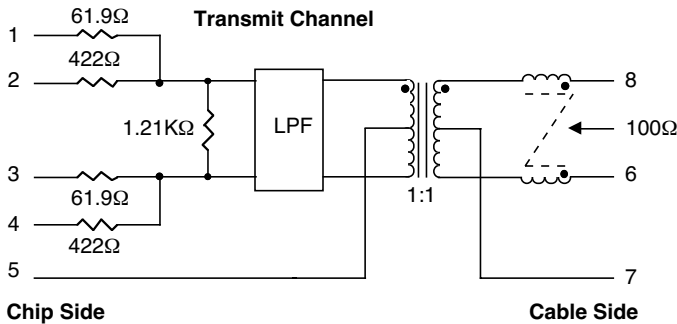

Package

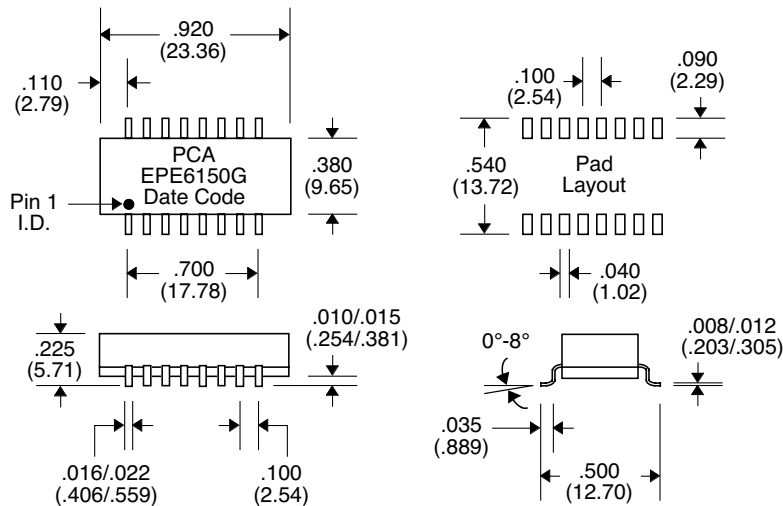

Unless Otherwise Specified Dimensions are in Inches /mm ±.010 /.25