

SmartStix GCL-TR2A / GCL-TR4A

High Speed Remote I/O for the i3 Family

16 DC Outputs (24VDC, positive logic, 0.5A) /

32 DC Outputs (24VDC, positive logic, 0.5A)



1 GENERAL SPECIFICATIONS

General Specifications				
Storage Temperature	-25° to 70° C	Operating and Storage Humidity	5 to 95% Non-condensing	
Operating Temperature	0° to 55° C	Pollution degree	2 or lower	
Atmosphere	Free from corrosive gases and excessive dust	Cooling method	Self-cooling	
Vibration				
Occasional Vibration				
Frequency	Acceleration	Amplitude	Sweep Count	
10 ≤ f < 57 Hz	-	0.075 mm	10 times in each direction for X,Y,Z	
57 ≤ f ≤ 150 Hz	9.8 m/s ² {1G}	-		
Continuous Vibration				
Frequency	Acceleration	Amplitude	Sweep Count	
10 ≤ f < 57 Hz	-	0.035 mm	10 times in each direction for X,Y,Z	
57 ≤ f ≤ 150 Hz	4.9 m/s ² {0.5G}	-		
Shocks				
Maximum shock acceleration	147 m/s ² {15G}			
Duration Time	11 ms.			
Pulse Wave	Half sine wave pulse (3 times in each of X, Y, Z directions)			
Noise Immunity				
Square wave impulse noise	AC: ± 1,500VDC DC: ± 900VDC			
Electrostatic Discharge	Voltage: 4kV (contact discharge)			
Radiated electromagnetic field	27 – 500MHz, 10V/m			
Fast Transient Burst Noise	Severity level	All power modules	Digital I/Os (Ue < 24 V) Analogue I/Os Communication I/Os	Digital I/Os (Ue < 24 V) Analogue I/Os Communication I/Os
	Voltage	2 kV	1 kV	0.25 kV

2 DIMENSIONS

a. TR4A

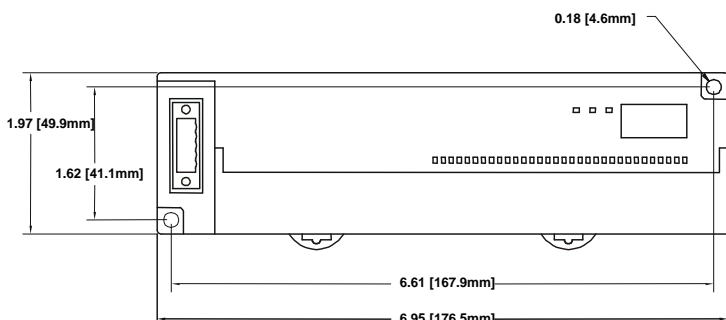

b. TR2A

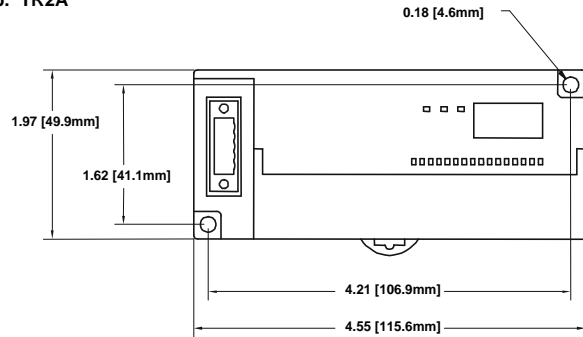

c. Terminal Strips

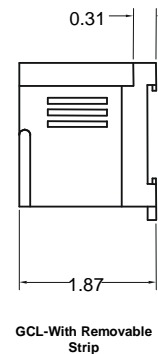

3 NETWORK CABLE

For detailed wiring information, refer to the Remote I/O Tutorial.
<http://www.imopc.com/download/912/i3-tutorial-remote-i-o.html>

Pin	Description	Recommended Cable	
① RED	1 V+	Thick: (Max Distance = 500m)	Belden 3082A
② WHT	2 CAN_H		
③ NC	3 No Connection	Thin: (Max Distance = 100m)	Belden 3084A
④ BLU	4 CAN_L		
⑤ BLK	5 V-		

4 ID SWITCHES (SETTING iCAN NETWORK IDs)

iCAN Network IDs are set using the hexadecimal number system from 01 to FD. The decimal equivalent is 1-253. Refer to Section 8, which shows the decimal equivalent of hexadecimal numbers. Set a unique Network ID by inserting a small Phillips screwdriver into the two *identical* switches. **Note:** The iCAN Baud Rate for SmartStix I/O is fixed at 125KBaud

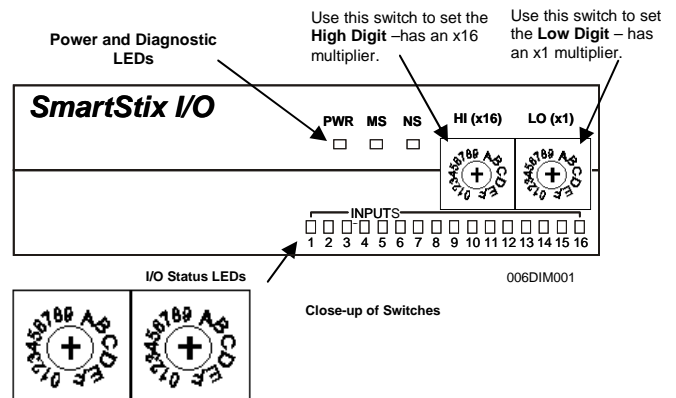

5 LEDs

a. Diagnostic LED Indicators

Diagnostic LED	State	Meaning
MS: (indicates fault status of Module)	Solid Red	RAM or ROM test failed
	Blinking Red	I/O test failed
	Blinking Green	Module is in power-up state
	Solid Green	Module is running normally
NS: (indicates fault status of Network)	Solid Red	Network Ack or Dup ID test failed
	Blinking Red	Network ID test failed
	Blinking Green	Module is in Life Expectancy default state
	Solid Green	Network is running normally

b. Status LED Indicators

The Power Status LED illuminates Red when power is applied to the module. There are I/O Status LED indicators for each of the Digital I/O points, which illuminate Red when an I/O point is ON.

6 WIRING

a. 16 DC OUT, Positive Logic

TR2A Outputs			
Number of output points	16	External Power Supply	Voltage
Commons per Module	1		Current
Operating Voltage	24VDC	OFF to ON Response	2ms.
Rated Load Voltage	24VDC	ON to OFF Response	2ms.
Max. Load Current per channel	0.5A Max. per output 3A per common	Output Type	Sourcing
OFF Leakage Current	0.1mA or less	Common Method	16 points / COM
Max. Inrush Current per channel	1A, 10ms	Operating Indicator	LED turns on during ON state of output
		External connections	Terminal block connector (M3 x 6 screws)
Maximum Voltage Drop during ON circuit	1.5VDC(0.5A)	Isolation methods	Photo Coupler
Rated Voltage	11 – 25 VDC		
Internal power Consumption (mA)	280	Weight	6.7 oz. (191g)

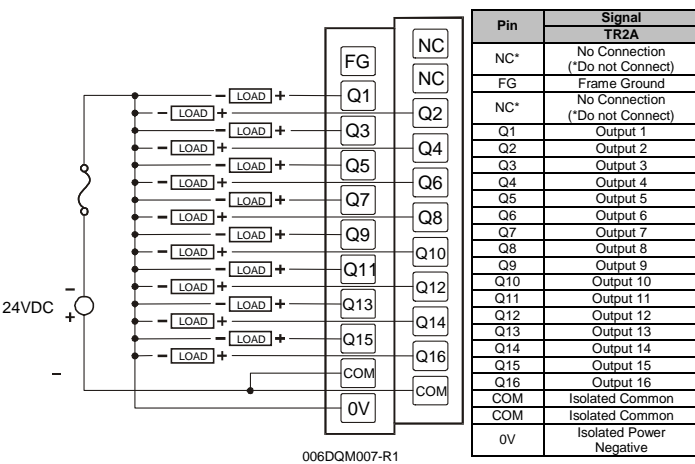

b. 32 DC OUT, Positive Logic

TR4A Outputs			
Number of output points	32	External Power Supply	Voltage
Commons per Module	2		Current
Operating Voltage	24VDC	OFF to ON Response	2ms.
Rated Load Voltage	24VDC	ON to OFF Response	2ms.
Max. Load Current per channel	0.5A Max. per output 3A per common	Output Type	Sourcing
OFF Leakage Current	0.1mA or less	Common Method	16 points / COM
Max. Inrush Current per channel	1A, 10ms	Operating Indicator	LED turns on during ON state of output
		External connections	Terminal block connector (M3 x 6 screws)
Maximum Voltage Drop during ON circuit	1.5VDC(0.5A)	Isolation methods	Photo Coupler
Rated Voltage	11 – 25 VDC		
Internal power Consumption (mA)	380	Weight	10.22 (290g)

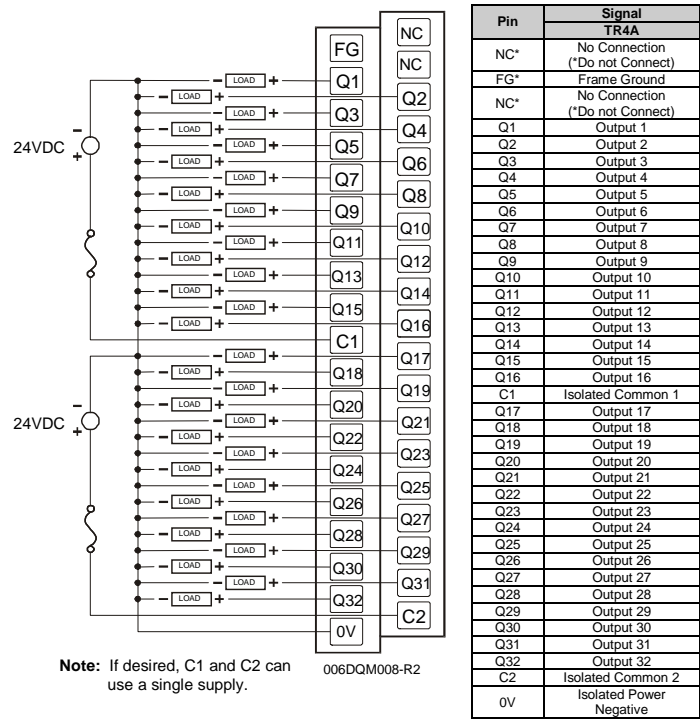

Note: If desired, C1 and C2 can use a single supply.

7 INTERNAL WIRING

a. TR2A

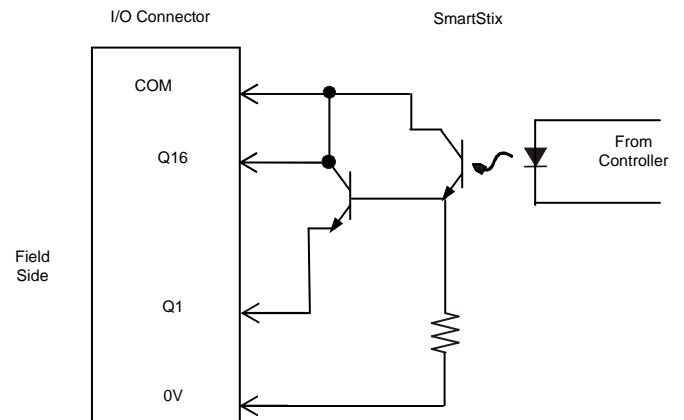

b. TR4A

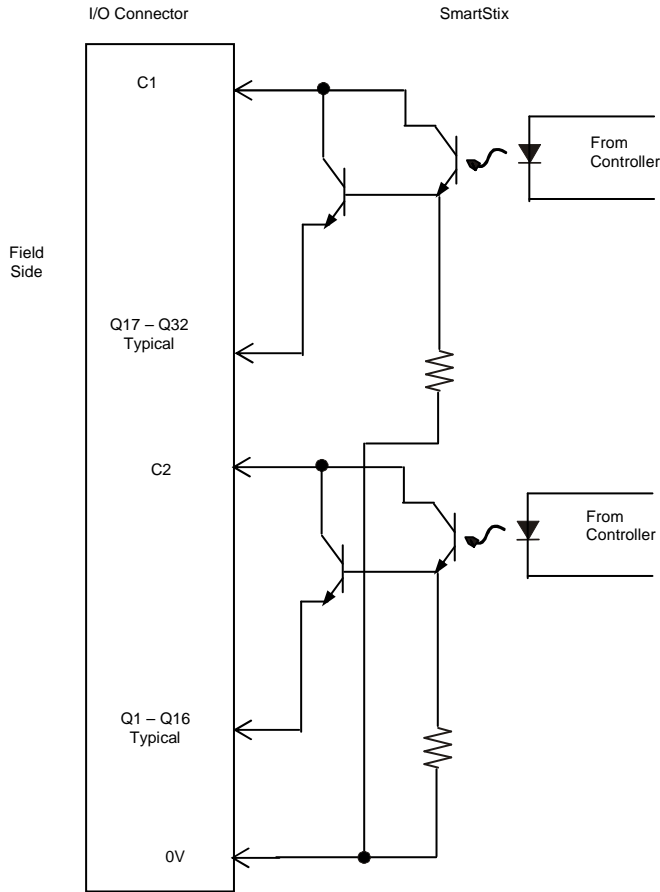

37	2	5	123	7	B	209	D	1
38	2	6	124	7	C	210	D	2
39	2	7	125	7	D	211	D	3
40	2	8	126	7	E	212	D	4
41	2	9	127	7	F	213	D	5
42	2	A	128	8	0	214	D	6
43	2	B	129	8	1	215	D	7
44	2	C	130	8	2	216	D	8
45	2	D	131	8	3	217	D	9
46	2	E	132	8	4	218	D	A
47	2	F	133	8	5	219	D	B
48	3	0	134	8	6	220	D	C
49	3	1	135	8	7	221	D	D
50	3	2	136	8	8	222	D	E
51	3	3	137	8	9	223	D	F
52	3	4	138	8	A	224	E	0
53	3	5	139	8	B	225	E	1
54	3	6	140	8	C	226	E	2
55	3	7	141	8	D	227	E	3
56	3	8	142	8	E	228	E	4
57	3	9	143	8	F	229	E	5
58	3	A	144	9	0	230	E	6
59	3	B	145	9	1	231	E	7
60	3	C	146	9	2	232	E	8
61	3	D	147	9	3	233	E	9
62	3	E	148	9	4	234	E	A
63	3	F	149	9	5	235	E	B
64	4	0	150	9	6	236	E	C
65	4	1	151	9	7	237	E	D
66	4	2	152	9	8	238	E	E
67	4	3	153	9	9	239	E	F
68	4	4	154	9	A	240	F	0
69	4	5	155	9	B	241	F	1
70	4	6	156	9	C	242	F	2
71	4	7	157	9	D	243	F	3
72	4	8	158	9	E	244	F	4
73	4	9	159	9	F	245	F	5
74	4	A	160	A	0	246	F	6
75	4	B	161	A	1	247	F	7
76	4	C	162	A	2	248	F	8
77	4	D	163	A	3	249	F	9
78	4	E	164	A	4	250	F	A
79	4	F	165	A	5	251	F	B
80	5	0	166	A	6	252	F	C
81	5	1	167	A	7	253	F	D
82	5	2	168	A	8	254	F	E
83	5	3	169	A	9	255	F	F
84	5	4	170	A	A			
85	5	5	171	A	B			

8 DECIMAL (DEC) TO HEXADECIMAL (HEX) CONVERSION TABLE

Dec	Hex		Dec	Hex		Dec	Hex	
	HI	LO		HI	LO		HI	LO
0	0	0	86	5	6	172	A	C
1	0	1	87	5	7	173	A	D
2	0	2	88	5	8	174	A	E
3	0	3	89	5	9	175	A	F
4	0	4	90	5	A	176	B	0
5	0	5	91	5	B	177	B	1
6	0	6	92	5	C	178	B	2
7	0	7	93	5	D	179	B	3
8	0	8	94	5	E	180	B	4
9	0	9	95	5	F	181	B	5
10	0	A	96	6	0	182	B	6
11	0	B	97	6	1	183	B	7
12	0	C	98	6	2	184	B	8
13	0	D	99	6	3	185	B	9
14	0	E	100	6	4	186	B	A
15	0	F	101	6	5	187	B	B
16	1	0	102	6	6	188	B	C
17	1	1	103	6	7	189	B	D
18	1	2	104	6	8	190	B	E
19	1	3	105	6	9	191	B	F
20	1	4	106	6	A	192	C	0
21	1	5	107	6	B	193	C	1
22	1	6	108	6	C	194	C	2
23	1	7	109	6	D	195	C	3
24	1	8	110	6	E	196	C	4
25	1	9	111	6	F	197	C	5
26	1	A	112	7	0	198	C	6
27	1	B	113	7	1	199	C	7
28	1	C	114	7	2	200	C	8
29	1	D	115	7	3	201	C	9
30	1	E	116	7	4	202	C	A
31	1	F	117	7	5	203	C	B
32	2	0	118	7	6	204	C	C
33	2	1	119	7	7	205	C	D
34	2	2	120	7	8	206	C	E
35	2	3	121	7	9	207	C	F
36	2	4	122	7	A	208	D	0

9 INSTALLATION / SAFETY

- a. All applicable codes and standards need to be followed in the installation of this product.
- b. For I/O wiring (discrete), use the following wire type or equivalent: Belden 8441 or equivalent.
- c. For detailed installation information, refer to Remote I/O tutorial. <http://www.imopc.com/download/912/i3-tutorial-remote-i-o.html>

Warning: Consult user documentation.

Warning: Electrical Shock Hazard.

Warning: To protect the module and associated wiring from load faults, use external fuse (5 A).

Warning: Connecting high voltage to any I/O pin may cause high voltage to appear at other I/O pins.

Warning: Wiring the line side of the AC source to loads connected to outputs 0 through 15 and the neutral side of the AC source to the output common(s) would create a Negative Logic condition, which may be considered an unsafe practice.

10 TECHNICAL ASSISTANCE

For assistance and manual updates, contact Technical Support: automation@imopc.com