

SmartStix Analogue I/O Modules

High Speed Remote I/O for the i3 Family

GCL-AT0A / GCL-AT1A

4 Input Channels, 2 Output Channels / 8 Input Channels, 4 Sourcing Output Channels

±5V / ±10V / 4-20mA / ±20mA



1 SPECIFICATIONS

ANALOGUE IN				
Input Ranges	±5V, ±10V DC 4-20mA, ±20mA DC		Isolation	1000V DC IEC61010-1 300V RMS
Resolution	14 bits		Isolation Method	Magnetic
Input Impedance	V: 1 Megohm mA: 150 Ohms		Maximum Continuous Overload	±10V: 150VAC ±20mA: ±30mA, Clamped at ±6V
Filter Modes	Running Average or Adaptive		Programmable Filter Time Constants	0.01 to 1.28 Seconds
ANALOGUE OUT				
Output Ranges	±5, ±10V DC 4-20mA, ±20mA DC		Isolation	1000V DC IEC61010-1 300V RMS
Resolution	14 bits		Isolation Method	Magnetic
Load Resistance	V: 600 Min mA: 500 Max		Output Clamp	±12V, 600Wpk
			Output Characteristic	Sourcing
GENERAL				
Required Power (Steady State)	3.6W (150ma @ 24VDC)		Operating Temperature	0° to 55° C
Required Power (Inrush)	8A @ 24VDC for 1ms		Operating and Storage Humidity	5 to 95% Non-condensing
Storage Temperature	-25° to 70° C		Altitude for use	Up to 2,000m
Atmosphere	Free from corrosive gases and excessive dust		Pollution degree	2 or lower
			Cooling method	Self-cooling
Vibration				
Occasional Vibration				
Frequency	Acceleration	Amplitude	Sweep Count	
10 ≤ f < 57 Hz	-	0.075 mm	10 times in each direction for X, Y, Z	
57 ≤ f ≤ 150 Hz	9.8 m/s ² {1G}	-		
Continuous Vibration				
Frequency	Acceleration	Amplitude	Sweep Count	
10 ≤ f < 57 Hz	-	0.035 mm	10 times in each direction for X, Y, Z	
57 ≤ f ≤ 150 Hz	4.9 m/s ² {0.5G}	-		
Shocks				
Maximum shock acceleration	147 m/s ² {15G}			
Duration Time	11 ms.			
Pulse Wave	Half sine wave pulse (3 times in each of X, Y, Z directions)			
Noise Immunity				
Square wave impulse noise	AC: ± 1,500VDC DC: ± 900VDC			
Electrostatic Discharge	Voltage: 4kV (contact discharge)			
Radiated electromagnetic field	27 – 500MHz, 10V/m			
Fast Transient Burst Noise	Severity level	All power modules	Digital I/Os (Ue ≥ 24V)	Digital I/Os (Ue < 24 V) Analogue I/Os Communication I/Os
	Voltage	2 kV	1 kV	0.25 kV
ANALOGUE IN				
	AT0A		AT1A	
Number of input points	4		8	
Conversion Time	5ms for all Channels		10ms for all Channels	
Accuracy, 25°C	0.3%		0.1%	
Register Value for Nominal Full Scale	32000		±32000	
ANALOGUE OUT				
Number of output points	2		4	
Accuracy, 25°C	0.3%		0.1%	
Register Value for Nominal Full Scale	32000		±32000	
Max Output current, mA mode	-		3 channels driving 20mA max output loads	
GENERAL				
Weight	8.40 oz. (238 g)		9 oz. (256g)	

Refer to SmartStix Remote I/O Tutorial: <http://www.imopc.com/download/912/i3-tutorial-remote-i-o.html>

2 DIMENSIONS

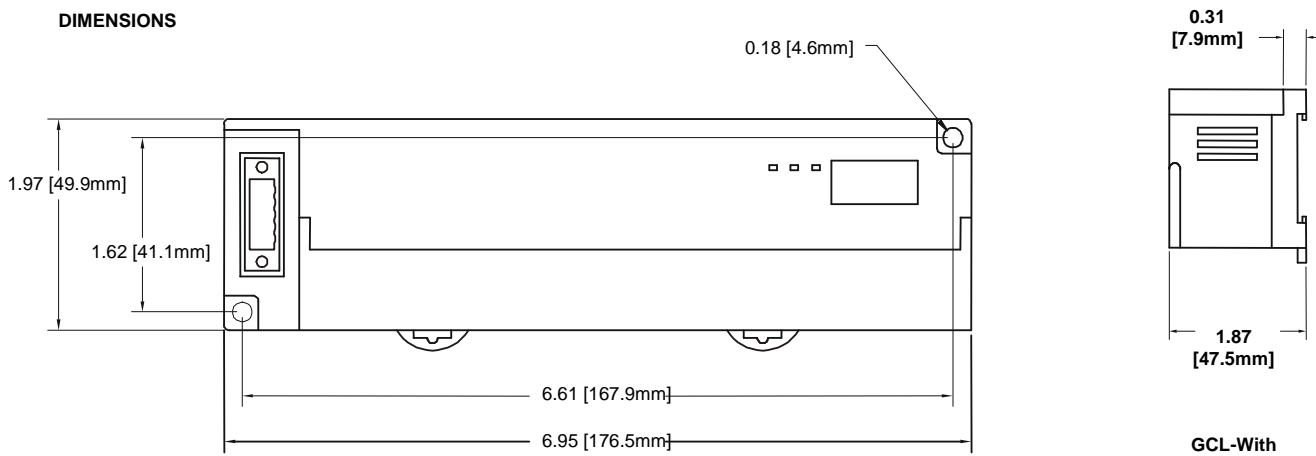

GCL-With Removable Terminal

3 WIRING

a. AT0A

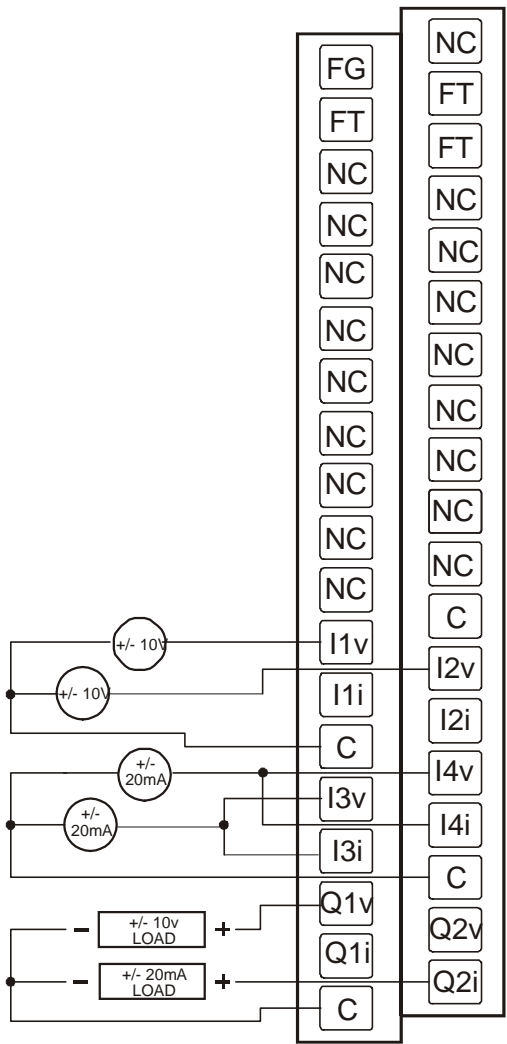

006MIX003-R1

AT0A		AT0A	
2	FG	1	NC
4	FT	3	FT
6	NC	5	FT
8	NC	7	NC
10	NC	9	NC
12	NC	11	NC
14	NC	13	NC
16	NC	15	NC
18	NC	17	NC
20	NC	19	NC
22	NC	21	NC
24	I1v	23	C
26	I1i	25	I2v
28	C	27	I2i
30	I3v	29	I4v
32	I3i	31	I4i
34	Q1v	33	C
36	Q1i	35	Q2v
38	C	37	Q2i

FT: Factory Test, Do Not Connect
 FG: Frame Ground

C terminals are connected together internally but isolated from bus and power circuits.

b. AT1A

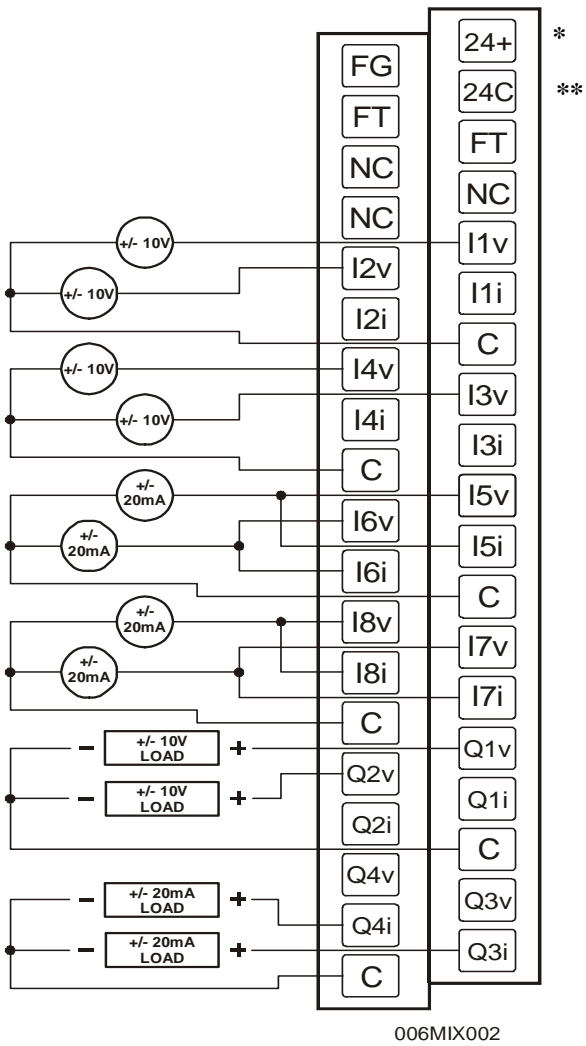

AT1A		AT1A	
2	FG	1	24+ *
4	FT	3	24C **
6	NC	5	FT
8	NC	7	NC
10	I2v	9	I1v
12	I2i	11	I1i
14	I4v	13	C
16	I4i	15	I3v
18	C	17	I3i
20	I6v	19	I5v
22	I6i	21	I5i
24	I8v	23	C
26	I8i	25	I7v
28	C	27	I7i
30	Q2v	29	Q1v
32	Q2i	31	Q1i
34	Q4v	33	C
36	Q4i	35	Q3v
38	C	37	Q3i

FT: Factory Test, Do **Not** Connect
 FG: Frame Ground

C terminals are connected together internally but isolated from bus and power circuits.

* and ** For iCAN and DeviceNet versions, module power is usually derived from the CAN connector. In that case, +24VDC and 24C are not connected.

4 INTERNAL WIRING

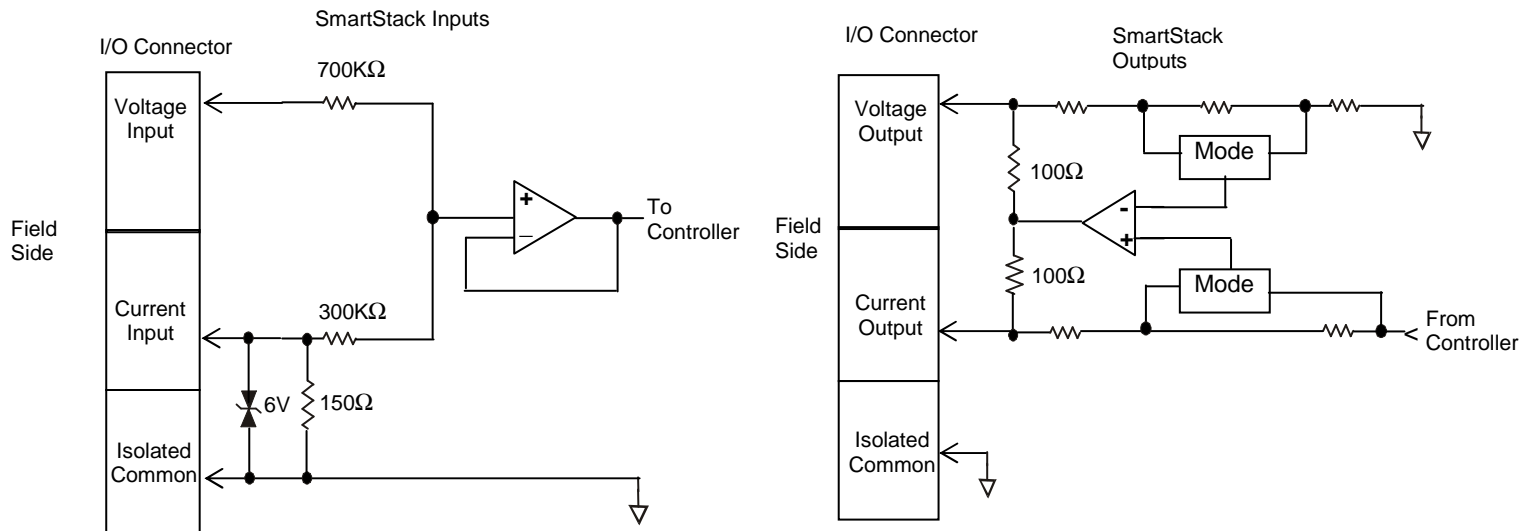

5 CHANNEL MODE, PROGRAMMABLE FILTER, AND OUTPUT DEFAULT CONFIGURATION

The network supplies configuration information to the unit in the Consumed Directed Digital Data Words sent to the unit. In the first word, the low 12 bits, 1 through 12, are channel mode bits. A low mode bit selects $\pm 10V$ and a high mode bit selects $\pm 20mA$. The next three bits, 13 through 15, are input digital filter time constant codes and the high bit, 16, is an adaptive filter enable bit. In the second word, the low 12 bits are channel scale bits. A low scale bit selects $\pm 10V$ or $\pm 20mA$ for the corresponding channel. A high scale bit selects $\pm 5V$ or $4\text{-}20mA$. The upper four bits are unused.

Bit	AT0A Channel	AT1A Channel
1	AI1	AI1
2	AI2	AI2
3	AI3	AI3
4	AI4	AI4
5	Not used	AI5
6	Not used	AI6
7	Not used	AI7
8	Not used	AI8
9	AQ1	AQ1
10	AQ2	AQ2
11	Not used	AQ3
12	Not used	AQ4

Each analogue input on the unit has a single pole 345Hz (461 μ S) cutoff high frequency noise filter. In addition a second digital filter may be specified in the first configuration word with the following time constants.

Bit			Time Constant
15	14	13	
0	0	0	10 milliseconds (Nominal hardware scan rate)
0	0	1	15 milliseconds
0	1	0	35 milliseconds
0	1	1	75 milliseconds
1	0	0	155 milliseconds
1	0	1	315 milliseconds
1	1	0	635 milliseconds
1	1	1	1.275 seconds

This digital filter is useful for applications with significant amounts of random noise. The slower time constants, while yielding better noise suppression, take a longer time to settle after step changes and are also sensitive to impulse noise which is treated like Gaussian noise and averaged.

Bit 16 of the first configuration word may be set to specify an adaptive filter algorithm that:

1. Responds much more quickly to large step changes at slower time constants with full filtering of low level noise.
2. Suppresses impulse noise at the expense of slightly slower response at the shortest time constant settings. (Approximately 10 additional milliseconds)

Note that actual system response time is network dependent.

Bits 9 through 12 of the 5th configuration word control the behavior of the analogue outputs when network communication is lost. The bit to channel correspondence is the same as for the mode and scale bits. If the corresponding bit is set, the outputs hold the last state. If the corresponding bit is cleared, the outputs are set to the respective value supplied to the unit in the second four words of the Consumed Directed Analogue Data sent by the i3. The other bits of the 5th configuration word are unused.

Refer the Remote I/O Tutorial. <http://www.imopc.com/download/912/i3-tutorial-remote-i-o.html>

6 INPUT AND OUTPUT CONVERSION FACTORS

The following table describes how real-world values are scaled in the controller. For a given physical voltage or current, the register data value may be calculated by using the conversion factor from the table. The following formula is used: **Data = Voltage or Current / Conversion Factor**.

Example: The user selects a voltage range of $\pm 10V$:

1. The physical voltage is 6 Volts.
2. Using the table, the conversion factor for the voltage range of $\pm 10V$ is .0003125.
3. To determine the data value, the formula is used: $\text{Data} = V / \text{Conversion Factor}$
 $19200 = 6 \text{ VDC} / 0.0003125$

Conversion between Physical Values and Register Values			
Selected Range	Volts / mA	Register Data	Conversion Factor
$\pm 5.00 \text{ V}$	> +5.11	32767	0.00015625
	+5.00	32000	
	0.00	0	
	-5.00	-32000	
	< -5.11	-32768	
$\pm 10.00 \text{ V}$	> +10.23	32767	0.0003125
	+10.00	32000	
	0.00	0	
	-10.00	-32000	
	< -10.23	-32768	
4..20 mA	< +20.37	32767	0.0005
	+20.00	32000	
	+4.00	0	
	-12.00	-32000	
	> -12.38	-32768	
$\pm 20.00 \text{ mA}$	> +20.47	32767	0.0006250
	+20.00	32000	
	0	0	
	-20.00	-32000	
	< -20.47	-32768	

Note: For the 4 to 20mA range, the offset, 4mA, must first be subtracted from the physical output value before dividing by the scale factor to yield the register data value.

7 SETTING ID SWITCHES

iCAN Network IDs are set using the hexadecimal number system from 01 to FD. The decimal equivalent is 1-253. Refer to following Conversion Table, which shows the decimal equivalent of hexadecimal numbers. Set a unique Network ID by inserting a small Phillips screwdriver into the two *identical* switches.

Note: The iCAN Baud Rate for SmartStix I/O is fixed at 125KBaud.

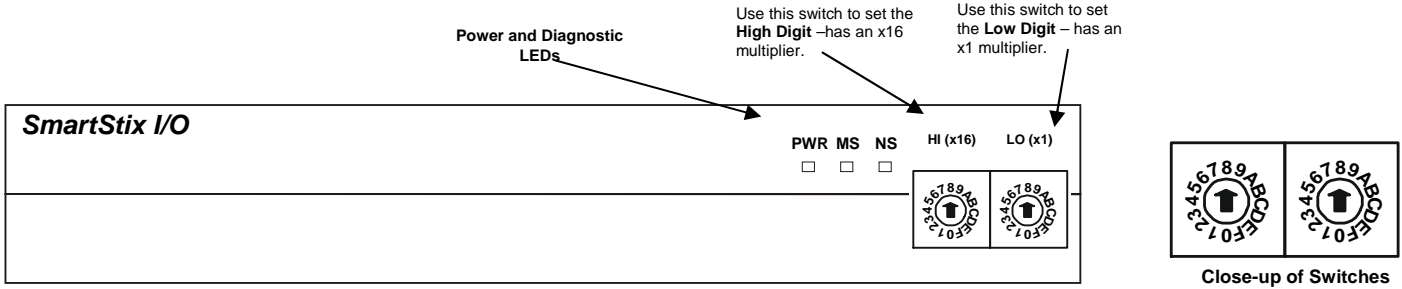

Decimal (Dec) to Hexadecimal (Hex) Conversion																	
Dec	Hex		Dec	Hex		Dec	Hex		Dec	Hex		Dec	Hex		Dec	Hex	
	HI	LO		HI	LO		HI	LO		HI	LO		HI	LO		HI	LO
1	0	1	46	2	E	92	5	C	138	8	A	184	B	8	230	E	6
2	0	2	47	2	F	93	5	D	139	8	B	185	B	9	231	E	7
3	0	3	48	3	0	94	5	E	140	8	C	186	B	A	232	E	8
4	0	4	49	3	1	95	5	F	141	8	D	187	B	B	233	E	9
5	0	5	50	3	2	96	6	0	142	8	E	188	B	C	234	E	A
6	0	6	51	3	3	97	6	1	143	8	F	189	B	D	235	E	B
7	0	7	52	3	4	98	6	2	144	9	0	190	B	E	236	E	C
8	0	8	53	3	5	99	6	3	145	9	1	191	B	F	237	E	D
9	0	9	54	3	6	100	6	4	146	9	2	192	C	0	238	E	E
10	0	A	55	3	7	101	6	5	147	9	3	193	C	1	239	E	F
11	0	B	56	3	8	102	6	6	148	9	4	194	C	2	240	F	0
12	0	C	57	3	9	103	6	7	149	9	5	195	C	3	241	F	1
13	0	D	58	3	A	104	6	8	150	9	6	196	C	4	242	F	2
14	0	E	59	3	B	105	6	9	151	9	7	197	C	5	243	F	3
15	0	F	60	3	C	106	6	A	152	9	8	198	C	6	244	F	4
16	1	0	61	3	D	107	6	B	153	9	9	199	C	7	245	F	5
17	1	1	62	3	E	108	6	C	154	9	A	200	C	8	246	F	6
18	1	2	63	3	F	109	6	D	155	9	B	201	C	9	247	F	7
19	1	3	64	4	0	110	6	E	156	9	C	202	C	A	248	F	8
20	1	4	65	4	1	111	6	F	157	9	D	203	C	B	249	F	9
21	1	5	66	4	2	112	7	0	158	9	E	204	C	C	250	F	A
22	1	6	67	4	3	113	7	1	159	9	F	205	C	D	251	F	B
23	1	7	68	4	4	114	7	2	160	A	0	206	C	E	252	F	C
24	1	8	69	4	5	115	7	3	161	A	1	207	C	F	253	F	D
25	1	9	70	4	6	116	7	4	162	A	2	208	D	0			
26	1	A	71	4	7	117	7	5	163	A	3	209	D	1			
27	1	B	72	4	8	118	7	6	164	A	4	210	D	2			
28	1	C	73	4	9	119	7	7	165	A	5	211	D	3			
29	1	D	74	4	A	120	7	8	166	A	6	212	D	4			
30	1	E	75	4	B	121	7	9	167	A	7	213	D	5			
31	1	F	76	4	C	122	7	A	168	A	8	214	D	6			
32	2	0	77	4	D	123	7	B	169	A	9	215	D	7			
33	2	1	78	4	E	124	7	C	170	A	A	216	D	8			
34	2	2	79	4	F	125	7	D	171	A	B	217	D	9			
35	2	3	80	5	0	126	7	E	172	A	C	218	D	A			
36	2	4	81	5	1	127	7	F	173	A	D	219	D	B			
37	2	5	82	5	2	128	8	0	174	A	E	220	D	C			
38	2	6	83	5	3	129	8	1	175	A	F	221	D	D			
39	2	7	84	5	4	130	8	2	176	B	0	222	D	E			
40	2	8	85	5	5	131	8	3	177	B	1	223	D	F			
41	2	9	86	5	6	132	8	4	178	B	2	224	E	0			
42	2	A	87	5	7	133	8	5	179	B	3	225	E	1			
43	2	B	88	5	8	134	8	6	180	B	4	226	E	2			
44	2	C	89	5	9	135	8	7	181	B	5	227	E	3			
45	2	D	90	5	A	136	8	8	182	B	6	228	E	4			
			91	5	B	137	8	9	183	B	7	229	E	5			





8 **LEDS**

SmartStix I/O Modules provide diagnostic and status LED indicators.

a. Diagnostic LED Indicators			b. Status LED Indicators
Diagnostic LED	State	Meaning	The Power Status LED illuminates Red when power is applied to the module. There are I/O Status LED indicators for each of the Digital I/O points, which illuminate Red when an I/O point is ON.
MS (Module Status)	Solid Red	RAM or ROM test failed	
	Blinking Red	I/O test failed, internal hardware fault	
	Blinking Green	Module is in power-up state *	
	Solid Green	Module is running normally	
NS (Network Status)	Solid Red	Network Ack or Dup ID test failed **	
	Blinking Red	Network ID test failed: ID not in the range of 1..253	
	Blinking Green	Life Expectancy timeout, outputs are in default state ***	
	Solid Green	Network is running normally	
* If a blinking green Module Status persists for more than a few seconds the module has not received the expected configuration from the i3. This may be due to no Network I/O configuration created in i3 Configurator, not having downloaded the Network I/O configuration to the master i3, an unpowered master i3, or the wrong Network ID number set on the module's rotary switches. ** Network Ack means that no other node is active on the network. Dup ID test failed means that another node with the same ID switch setting is already on the network. *** Life Expectancy timeout means that the module has not received a periodic message from the master i3 in the time specified in either the Life Expectancy directed data message or the Comm timeout of the Network I/O Configuration window in i3 Configurator.			

9 **NETWORK CABLE**

For detailed wiring information, refer to the Remote I/O Tutorial. <http://www.imopc.com/download/912/i3-tutorial-remote-i-o.html>

	Pin	Description
	RED 1	V+
	WHT 2	CAN_H
	NC 3	No Connection
	BLU 4	CAN_L
	BLK 5	V-

Recommended Cable	
Thick: (Max Distance = 500m)	Belden 3082A
Thin: (Max Distance = 100m)	Belden 3084A

10 **INSTALLATION / SAFETY**

When found on the product, the following symbols specify:



Warning: Consult user documentation.



Warning: Electrical Shock Hazard.

WARNING: To avoid the risk of electric shock or burns, always connect the safety (or earth) ground before making any other connections.

WARNING: To reduce the risk of fire, electrical shock, or physical injury it is strongly recommended to fuse the voltage measurement inputs. Be sure to locate fuses as close to the source as possible.

WARNING: Replace fuse with the same type and rating to provide protection against risk of fire and shock hazards.

WARNING: In the event of repeated failure, do not replace the fuse again as a repeated failure indicates a defective condition that will not clear by replacing the fuse.

WARNING: Only qualified electrical personnel familiar with the construction and operation of this equipment and the hazards involved should install, adjust, operate, or service this equipment. Read and understand this manual and other applicable manuals in their entirety before proceeding. Failure to observe this precaution could result in severe bodily injury or loss of life.

For detailed installation and panel box layout requirements and minimum clearances, refer to the hardware manual of the controller you are using. (See the **Additional References** section in this document.).

- All applicable codes and standards need to be followed in the installation of this product.
- For I/O wiring (discrete), use the following wire type or equivalent: Belden 8441 or equivalent.

Adhere to the following safety precautions whenever any type of connection is made to the module.

- Connect the green safety (earth) ground first before making any other connections.
- When connecting to electric circuits or pulse-initiating equipment, open their related breakers. Do not make connections to live power lines.
- Make connections to the module first; then connect to the circuit to be monitored.
- Route power wires in a safe manner in accordance with good practice and local codes.
- Wear proper personal protective equipment including safety glasses and insulated gloves when making connections to power circuits.
- Ensure hands, shoes, and floor are dry before making any connection to a power line.
- Make sure the unit is turned OFF before making connection to terminals. Make sure all circuits are de-energized before making connections.
- Before each use, inspect all cables for breaks or cracks in the insulation. Replace immediately if defective.

11 **TECHNICAL ASSISTANCE**

For assistance and manual updates, contact Technical Support: automation@imopc.com