

SmartStix GCL-RY2A

High Speed Remote I/O for the i3 Family

16 Relay Outputs (250VAC, 30VDC, 2.0A)



1 GENERAL SPECIFICATIONS

| General Specifications | | | | |
|---------------------------------------|--|---------------------------------------|--------------------------------------|---|
| Storage Temperature | -25° to 70° C | Operating and Storage Humidity | 5 to 95% Non-condensing | |
| Operating Temperature | 0° to 55° C | Pollution degree | 2 or lower | |
| Atmosphere | Free from corrosive gases and excessive dust | Cooling method | Self-cooling | |
| Vibration | | | | |
| Occasional Vibration | | | | |
| Frequency | Acceleration | Amplitude | Sweep Count | |
| 10 ≤ f < 57 Hz | - | 0.075 mm | 10 times in each direction for X,Y,Z | |
| 57 ≤ f ≤ 150 Hz | 9.8 m/s ² {1G} | - | | |
| Continuous Vibration | | | | |
| Frequency | Acceleration | Amplitude | Sweep Count | |
| 10 ≤ f < 57 Hz | - | 0.035 mm | 10 times in each direction for X,Y,Z | |
| 57 ≤ f ≤ 150 Hz | 4.9 m/s ² {0.5G} | - | | |
| Shocks | | | | |
| Maximum shock acceleration | 147 m/s ² {15G} | | | |
| Duration Time | 11 ms. | | | |
| Pulse Wave | Half sine wave pulse (3 times in each of X, Y, Z directions) | | | |
| Noise Immunity | | | | |
| Square wave impulse noise | AC: ± 1,500VDC DC: ± 900VDC | | | |
| Electrostatic Discharge | Voltage: 4kV (contact discharge) | | | |
| Radiated electromagnetic field | 27 – 500MHz, 10V/m | | | |
| Fast Transient Burst Noise | Severity level | All power modules | Digital I/Os (Ue ≥ 24V) | Digital I/Os (Ue < 24 V) Analogue I/Os Communication I/Os |
| | Voltage | 2 kV | 1 kV | 0.25 kV |

2 DIMENSIONS

a. RY2A

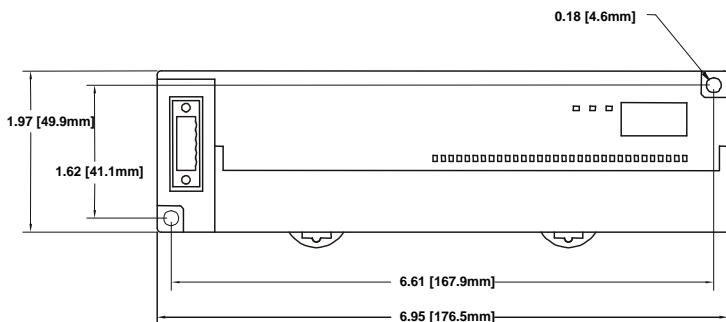

b. Terminal Strips

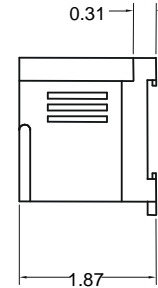

GCL-With Removable Strip

3 NETWORK CABLE

For detailed wiring information, refer to the Remote I/O Tutorial:
<http://www.imopc.com/download/912/i3-tutorial-remote-i-o.html>

| Pin | Description | Recommended Cable | |
|-----|-----------------|---------------------------------|--------------|
| RED | 1 V+ | Thick: (Max Distance = 500m) | Belden 3082A |
| WHT | 2 CAN_H | | |
| NC | 3 No Connection | Thin: (Max Distance = 100m) | Belden 3084A |
| BLU | 4 CAN_L | | |
| BLK | 5 V- | | |

4 ID SWITCHES (SETTING iCAN NETWORK IDs)

iCAN Network IDs are set using the hexadecimal number system from 01 to FD. The decimal equivalent is 1-253. Refer to Section 8, which shows the decimal equivalent of hexadecimal numbers. Set a unique Network ID by inserting a small Phillips screwdriver into the two *identical* switches. **Note:** The iCAN Baud Rate for SmartStix I/O is fixed at 125KBaud.

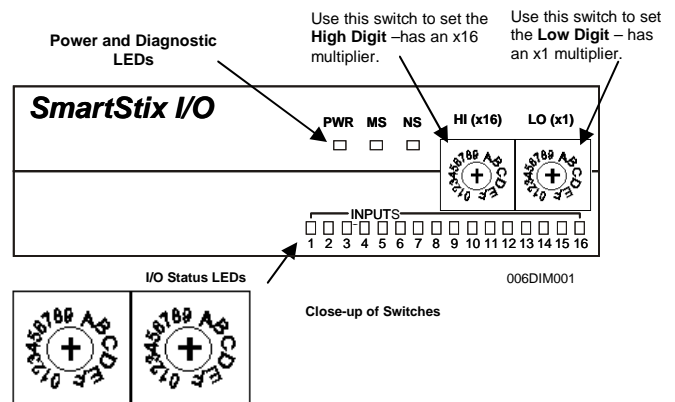

5 LEDs

a. Diagnostic LED Indicators

| Diagnostic LED | State | Meaning |
|--|----------------|--|
| MS: (indicates fault status of Module) | Solid Red | RAM or ROM test failed |
| | Blinking Red | I/O test failed |
| | Blinking Green | Module is in power-up state |
| | Solid Green | Module is running normally |
| NS: (indicates fault status of Network) | Solid Red | Network Ack or Dup ID test failed |
| | Blinking Red | Network ID test failed |
| | Blinking Green | Module is in Life Expectancy default state |
| | Solid Green | Network is running normally |

b. Status LED Indicators

The Power Status LED illuminates Red when power is applied to the module. There are I/O Status LED indicators for each of the Digital I/O points, which illuminate Red when an I/O point is ON.

6 WIRING

| RY2A Relay Outputs | | | |
|---------------------------------|---------------|----------------------------------|-------------------------------------|
| Number of output points | 16 | Minimum load voltage / current | 5VDC / 1mA |
| Commons per Module | 2 | Maximum Load Current (resistive) | 2.0A per channel 5.0A per common |
| Rated Load Voltage | 24VDC, 220VAC | OFF to ON Response | 10ms. Max. |
| Rated Voltage | 11 – 25 VDC | ON to OFF Response | 12ms. Max. |
| Internal power Consumption (mA) | 550mA | Output Type | N.O. |
| | | Weight | 9.91oz. (281 g) |

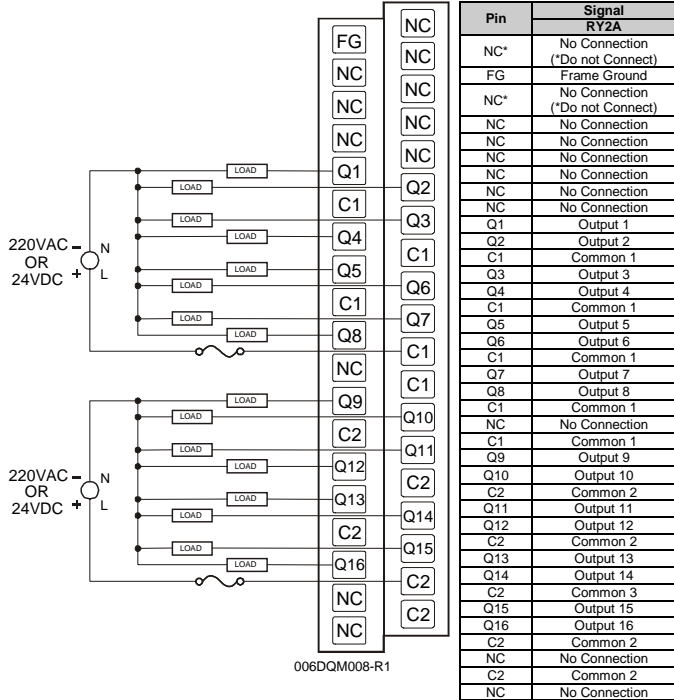

7 INTERNAL WIRING

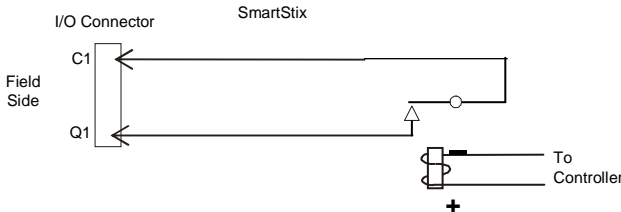

Specification for transient voltage suppressors (transorbs) used on output circuitry is 400VDC, bi-directional 400 watts.
Electro-mechanical relays comply with IEC1131-2.

8 DECIMAL (DEC) TO HEXADECEMAL (HEX) CONVERSION TABLE

| Dec | Hex | | | Dec | Hex | | | Dec | Hex | | |
|-----|-----|----|--|-----|-----|---|-----|-----|-----|----|--|
| | HI | LO | | HI | LO | | HI | LO | HI | LO | |
| 0 | 0 | 0 | | 86 | 5 | 6 | 172 | A | C | | |
| 1 | 0 | 1 | | 87 | 5 | 7 | 173 | A | D | | |
| 2 | 0 | 2 | | 88 | 5 | 8 | 174 | A | E | | |
| 3 | 0 | 3 | | 89 | 5 | 9 | 175 | A | F | | |
| 4 | 0 | 4 | | 90 | 5 | A | 176 | B | 0 | | |
| 5 | 0 | 5 | | 91 | 5 | B | 177 | B | 1 | | |
| 6 | 0 | 6 | | 92 | 5 | C | 178 | B | 2 | | |
| 7 | 0 | 7 | | 93 | 5 | D | 179 | B | 3 | | |
| 8 | 0 | 8 | | 94 | 5 | E | 180 | B | 4 | | |
| 9 | 0 | 9 | | 95 | 5 | F | 181 | B | 5 | | |
| 10 | 0 | A | | 96 | 6 | 0 | 182 | B | 6 | | |
| 11 | 0 | B | | 97 | 6 | 1 | 183 | B | 7 | | |
| 12 | 0 | C | | 98 | 6 | 2 | 184 | B | 8 | | |
| 13 | 0 | D | | 99 | 6 | 3 | 185 | B | 9 | | |
| 14 | 0 | E | | 100 | 6 | 4 | 186 | B | A | | |
| 15 | 0 | F | | 101 | 6 | 5 | 187 | B | B | | |
| 16 | 1 | 0 | | 102 | 6 | 6 | 188 | B | C | | |
| 17 | 1 | 1 | | 103 | 6 | 7 | 189 | B | D | | |
| 18 | 1 | 2 | | 104 | 6 | 8 | 190 | B | E | | |
| 19 | 1 | 3 | | 105 | 6 | 9 | 191 | B | F | | |
| 20 | 1 | 4 | | 106 | 6 | A | 192 | C | 0 | | |
| 21 | 1 | 5 | | 107 | 6 | B | 193 | C | 1 | | |
| 22 | 1 | 6 | | 108 | 6 | C | 194 | C | 2 | | |
| 23 | 1 | 7 | | 109 | 6 | D | 195 | C | 3 | | |
| 24 | 1 | 8 | | 110 | 6 | E | 196 | C | 4 | | |
| 25 | 1 | 9 | | 111 | 6 | F | 197 | C | 5 | | |
| 26 | 1 | A | | 112 | 7 | 0 | 198 | C | 6 | | |

| | | | | | | | | |
|----|---|---|-----|---|---|-----|---|---|
| 27 | 1 | B | 113 | 7 | 1 | 199 | C | 7 |
| 28 | 1 | C | 114 | 7 | 2 | 200 | C | 8 |
| 29 | 1 | D | 115 | 7 | 3 | 201 | C | 9 |
| 30 | 1 | E | 116 | 7 | 4 | 202 | C | A |
| 31 | 1 | F | 117 | 7 | 5 | 203 | C | B |
| 32 | 2 | 0 | 118 | 7 | 6 | 204 | C | C |
| 33 | 2 | 1 | 119 | 7 | 7 | 205 | C | D |
| 34 | 2 | 2 | 120 | 7 | 8 | 206 | C | E |
| 35 | 2 | 3 | 121 | 7 | 9 | 207 | C | F |
| 36 | 2 | 4 | 122 | 7 | A | 208 | D | 0 |
| 37 | 2 | 5 | 123 | 7 | B | 209 | D | 1 |
| 38 | 2 | 6 | 124 | 7 | C | 210 | D | 2 |
| 39 | 2 | 7 | 125 | 7 | D | 211 | D | 3 |
| 40 | 2 | 8 | 126 | 7 | E | 212 | D | 4 |
| 41 | 2 | 9 | 127 | 7 | F | 213 | D | 5 |
| 42 | 2 | A | 128 | 8 | 0 | 214 | D | 6 |
| 43 | 2 | B | 129 | 8 | 1 | 215 | D | 7 |
| 44 | 2 | C | 130 | 8 | 2 | 216 | D | 8 |
| 45 | 2 | D | 131 | 8 | 3 | 217 | D | 9 |
| 46 | 2 | E | 132 | 8 | 4 | 218 | D | A |
| 47 | 2 | F | 133 | 8 | 5 | 219 | D | B |
| 48 | 3 | 0 | 134 | 8 | 6 | 220 | D | C |
| 49 | 3 | 1 | 135 | 8 | 7 | 221 | D | D |
| 50 | 3 | 2 | 136 | 8 | 8 | 222 | D | E |
| 51 | 3 | 3 | 137 | 8 | 9 | 223 | D | F |
| 52 | 3 | 4 | 138 | 8 | A | 224 | E | 0 |
| 53 | 3 | 5 | 139 | 8 | B | 225 | E | 1 |
| 54 | 3 | 6 | 140 | 8 | C | 226 | E | 2 |
| 55 | 3 | 7 | 141 | 8 | D | 227 | E | 3 |
| 56 | 3 | 8 | 142 | 8 | E | 228 | E | 4 |
| 57 | 3 | 9 | 143 | 8 | F | 229 | E | 5 |
| 58 | 3 | A | 144 | 9 | 0 | 230 | E | 6 |
| 59 | 3 | B | 145 | 9 | 1 | 231 | E | 7 |
| 60 | 3 | C | 146 | 9 | 2 | 232 | E | 8 |
| 61 | 3 | D | 147 | 9 | 3 | 233 | E | 9 |
| 62 | 3 | E | 148 | 9 | 4 | 234 | E | A |
| 63 | 3 | F | 149 | 9 | 5 | 235 | E | B |
| 64 | 4 | 0 | 150 | 9 | 6 | 236 | E | C |
| 65 | 4 | 1 | 151 | 9 | 7 | 237 | E | D |
| 66 | 4 | 2 | 152 | 9 | 8 | 238 | E | E |
| 67 | 4 | 3 | 153 | 9 | 9 | 239 | E | F |
| 68 | 4 | 4 | 154 | 9 | A | 240 | F | 0 |
| 69 | 4 | 5 | 155 | 9 | B | 241 | F | 1 |
| 70 | 4 | 6 | 156 | 9 | C | 242 | F | 2 |
| 71 | 4 | 7 | 157 | 9 | D | 243 | F | 3 |
| 72 | 4 | 8 | 158 | 9 | E | 244 | F | 4 |
| 73 | 4 | 9 | 159 | 9 | F | 245 | F | 5 |
| 74 | 4 | A | 160 | A | 0 | 246 | F | 6 |
| 75 | 4 | B | 161 | A | 1 | 247 | F | 7 |
| 76 | 4 | C | 162 | A | 2 | 248 | F | 8 |
| 77 | 4 | D | 163 | A | 3 | 249 | F | 9 |
| 78 | 4 | E | 164 | A | 4 | 250 | F | A |
| 79 | 4 | F | 165 | A | 5 | 251 | F | B |
| 80 | 5 | 0 | 166 | A | 6 | 252 | F | C |
| 81 | 5 | 1 | 167 | A | 7 | 253 | F | D |
| 82 | 5 | 2 | 168 | A | 8 | 254 | F | E |
| 83 | 5 | 3 | 169 | A | 9 | 255 | F | F |
| 84 | 5 | 4 | 170 | A | A | | | |
| 85 | 5 | 5 | 171 | A | B | | | |

9 INSTALLATION / SAFETY

- All applicable codes and standards need to be followed in the installation of this product.
- For I/O wiring (discrete), use the following wire type or equivalent: Belden 8441 or equivalent.
- For detailed installation information, refer to the Remote I/O Tutorial. <http://www.imopc.com/download/912/i3-tutorial-remote-i-o.html>



Warning: Consult user documentation.



Warning: Electrical Shock Hazard.

Warning: To protect the module and associated wiring from load faults, use external fuse (5 A).
Warning: Connecting high voltage to any I/O pin may cause high voltage to appear at other I/O pins.
Warning: Wiring the line side of the AC source to loads connected to outputs 0 through 15 and the neutral side of the AC source to the output common(s) would create a Negative Logic condition, which may be considered an unsafe practice.

10 TECHNICAL ASSISTANCE

For assistance and manual updates, contact Technical Support: automation@imopc.com