



Features and Functions

Monitors and Reports on

- ◆ System integrity / battery health / output condition

Remote diagnostics and service features

- ◆ Monitor health and status of host power supply, battery set, and up to *twenty four individual outputs** (*requires M8 module)
- ◆ Auto-schedule or manual test and report battery standby time
- ◆ Remote supervision of battery's state of charge
- ◆ Remote monitoring and alert of external temperature fluctuations
- ◆ Monitoring of internal cabinet temperature
- ◆ Remote power cycling control of external equipment
- ◆ Time / date stamp system log reports of last 100 events

Email notification on

- ◆ AC and system fault occurrences
- ◆ Aging or drained battery
- ◆ Fire Alarm Interface (FAI) activation
- ◆ External room temperature outside preset limit
- ◆ External Event activation
- ◆ Output condition (requires M8 module)
 - Over voltage or over current | voltage loss | output power cycled

SNMP get, set and trap notification

- ◆ Version 1, 2, or 3

Ordering

Mechanical Information

NL4 4 Port Network Size: 4" x 2.5" x 1.5" Weight: .25 lb.

Cables and mounting hardware provided

Monitoring / Reporting / Test / and Control Functions

Monitored Parameters

Power Supply Output Voltage
AC Fault Status
System Fault Status
Fire Alarm Input Status
Battery Voltage
Battery Charge Current
Battery Age
Total Number of System Faults
Total Number of AC Faults
DC Load Current (*system or battery*)
DC Output Voltage (*system and battery*)
Event 1 (*user specified*)

Programmable Functions

AC Fault Delay
System Fault Delay
System Install Date
Reset Fault Counters
Optimal Battery Charge Current
Reset Battery Age Counter
Battery Replacement Period
Temperature Probe Trigger Parameters

Control Functions

Output 1 (*on or off*)
Output 2 (*on or off*)

Event-triggered Email Alerts & Reports

AC Fault Occurrence
System Fault Occurrence
FAI Activation Occurrence
Low Battery Occurrence
Battery Load Test Completed
General System Status Report
Scheduled System Service Due Alert
Battery Replacement Due Alert
Event Activation Alert (*user specified*)

Test Functions

Battery run time capacity
Battery state of charge

Description

The **NETLINK** module is part of **FLEXPOWER's** patented power management system for security and life safety applications.

NL4 is a four data port network module that communicates and controls power status over a local or wide area network. The NL4 provides four SPI ports for connection to FlexPower devices that enables monitoring and control of the power system. Typical data gathered and reported includes operational fault status, power supply output voltage, battery charging voltage, battery charging current, and fire alarm input status.

Automated reports may be generated on any detected fault condition, battery aging, fire alarm interface activation, and event activation, or on a time base for scheduled confirmation of proper operation. A time and date stamped log of the past 100 events is kept as history in a buffer and may be accessed as a scheduled report, or immediately on an alert or occurrence. The buffer is updated once per hour with all parameters in normal range.

In addition to four SPI connections, the NL4 provides two current sensor inputs, a remote temperature sensor input, a volt meter input, and a contact monitor input. The contact monitor input may be programmed to respond to either a normally open or normally closed contact or voltage presence or loss. Two outputs are also provided for use in power cycling external equipment with RB relay modules or interfacing to the C4, C8, or M8 modules.

Electrical Ratings

Specification

| | |
|-------------------------------------|-------------------------------|
| Input Operating Voltage | 9 to 30 VDC |
| Input Operating Current | 60 mA nominal |
| Network Data Rate | 10/100 Mbps |
| Voltage Measurement Range | 1 to 30 VDC ±5% |
| Current Measurement Range | 0 to 20A ±0.1A +5% of reading |
| Event Input | 9 to 32 VDC |
| Output 1, 2 Max Sink Current | 50 mA nominal |

Agency Listings UL2044, UL294, UL60950-1

Lifetime Warranty

Module Connections

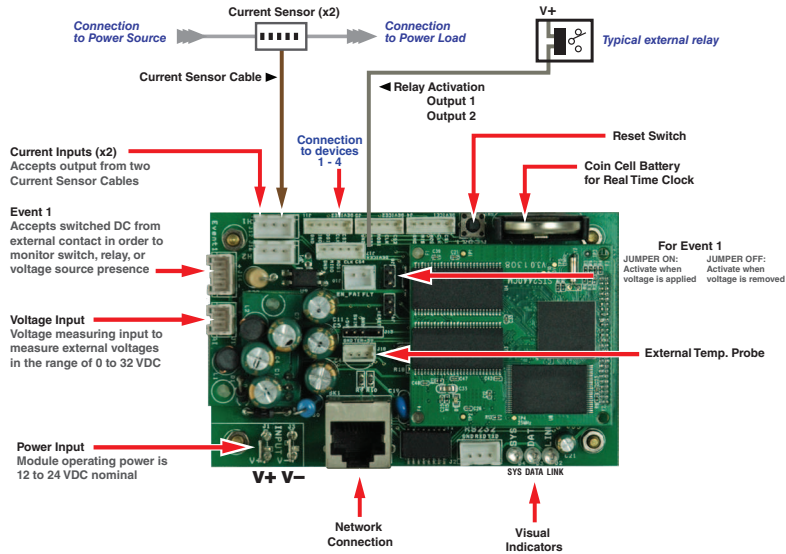

LifeSafety Power PowerCom® POWER SYSTEM MANAGER

HOME Reporting Configure Tools admin Log Out Ver: 6.06

SITE ID iSCAN
Date Fri Jul 26 2013 **Time** 12:49:39

Network Module Dashboard NL4 ver:0.9

Enclosure Temperature: 106.5 °F
 External temperature: 79.1 °F
 24V Battery set Current: 0.05 Amp
 B100 Current (amps): 0.83 Amp
 B100 Output (12 Volts): 12.58 VDC
 Event N/A: Inactive
 Service Due: No

View/Export past: 20 Hour(s) history GO

Device On/Off Control: Control 1 (ON/OFF), Control 2 (ON/OFF), Temperature (°F/°C)
 Increase MagLock 1 Current, Initiate fire Alarm, Submit

NL4 Connected Devices

| | |
|---|---|
| Device 1 Model: FPO250-200 Device ID: FP-1 Status: ● | Device 2 Model: M8 Device ID: M8-1 Status: ● |
| Device 3 Model: M8 Device ID: M8-2 Status: ● | Device 4 Model: M8 Device ID: M8-2 Status: ● |

NL4 Browser Home Screen

Network Dashboard

- ◆ Internal / external temperature sensors
- ◆ Current sensor reading
- ◆ Voltage sensor reading
- ◆ Event activation condition
- ◆ Service due report
- ◆ System log report
- ◆ Device on/off control

NL4 connected devices

- ◆ Two power supplies and 16 managed outputs
- ◆ One power supply and 24 managed outputs
- ◆ Visual status of device condition

Report Screen

- ◆ Set up screen
- ◆ What to report, when to report

Configure Screen

- ◆ Network, email, SNMP settings
- ◆ Current sensor calibration
- ◆ Battery life/capacity setting

Programming Screen

- ◆ Set FPO battery charge current
- ◆ Set fault report delays
- ◆ Reset timer for new battery instal
- ◆ Reset fault counters

Tools Screen

- ◆ Upgrade software
- ◆ System reboot
- ◆ System activity log

LifeSafetyPower.com

(888) 577-2898
 info@lifesafetypower.com

Specifications subject to change without notice.

© 2014 LifeSafety Power Inc. All rights reserved. LifeSafety Power and FlexPower are registered trademarks of LifeSafety Power Inc. All other trademarks and copyrights are the property of their respective owners.

P01-393A 08/14

LifeSafety Power, Inc.
 750 Tower Road, Unit B
 Mundelein, IL 60060 USA

See NL4 installation manual for comprehensive guide to features