

U1

SAM9x5-CM part numbers:

- SAM9G35-CM - populated AT91SAM9G35
- SAM9G25-CM - populated AT91SAM9G25
- SAM9G15-CM - populated AT91SAM9G15
- SAM9X35-CM - populated AT91SAM9X35
- SAM9X25-CM - populated AT91SAM9X25

- SAM9G35-CM-PHY - populated AT91SAM9G35 and ETH PHY
- SAM9G25-CM-PHY - populated AT91SAM9G25 and ETH PHY
- SAM9X35-CM-PHY - populated AT91SAM9X35 and ETH PHY
- SAM9X25-CM-PHY - populated AT91SAM9X25 and ETH PHY

All modules also available for -40° +85°C

Release notes v2.1:

- added R52 - 1.5k pulldown for TST
- added R55 - 100k pullup for NRST
- added R53, C43 - RC filter for DDR_VREF
- added R30, R51 - serial to USBC
- added U10 - 1.0V Linear for PLL and UTMIC
- added R56 - serial to DS2431P+
- added RR24, RR25 - serial to SPI Flash

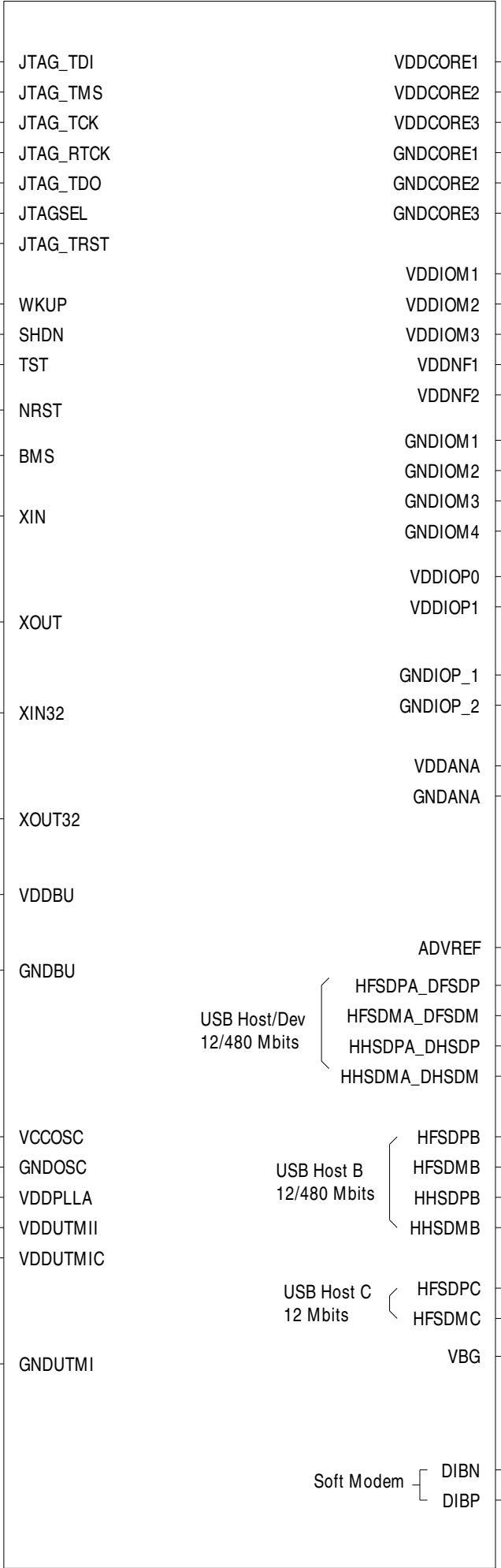
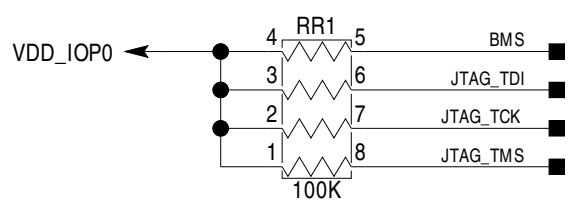
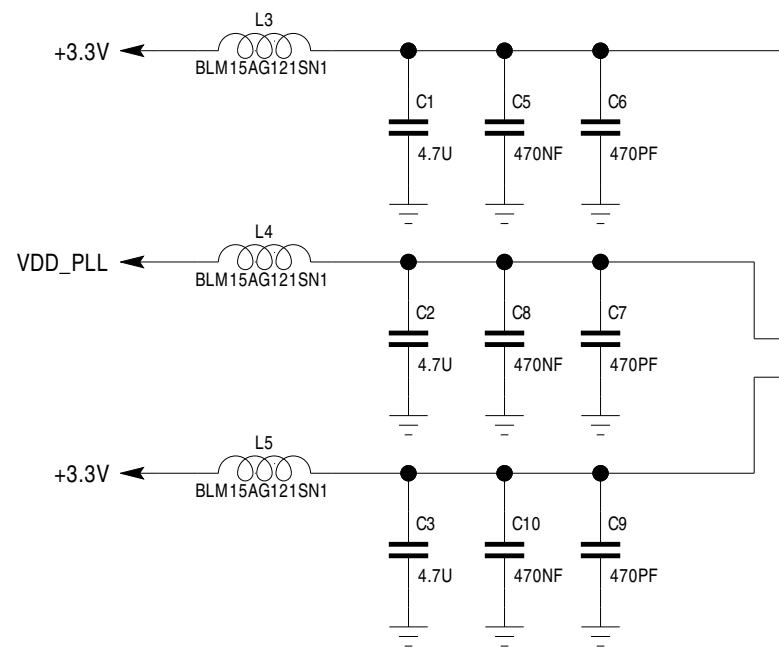
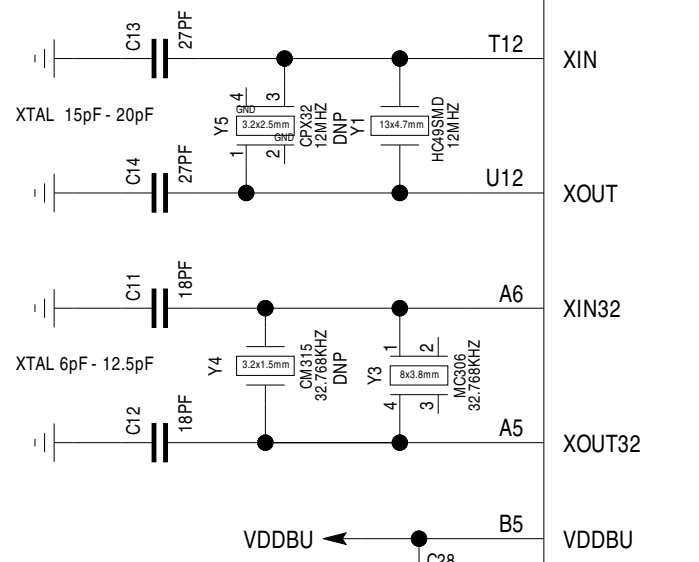
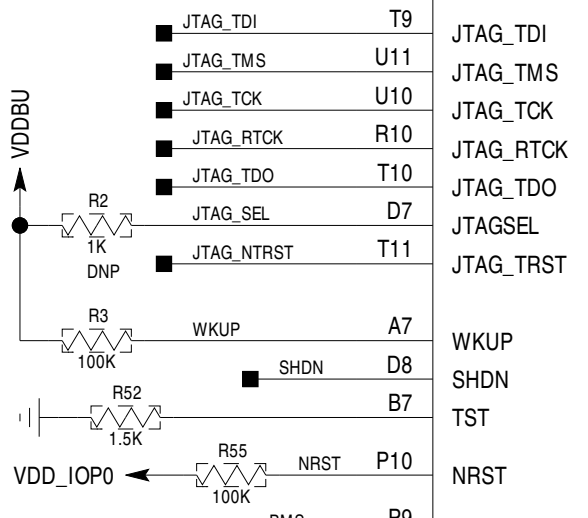

AT91SAM9x5

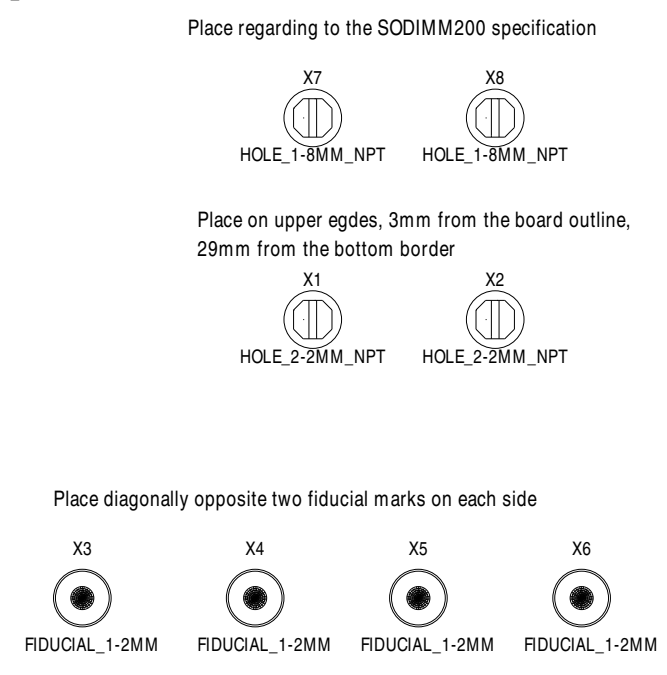
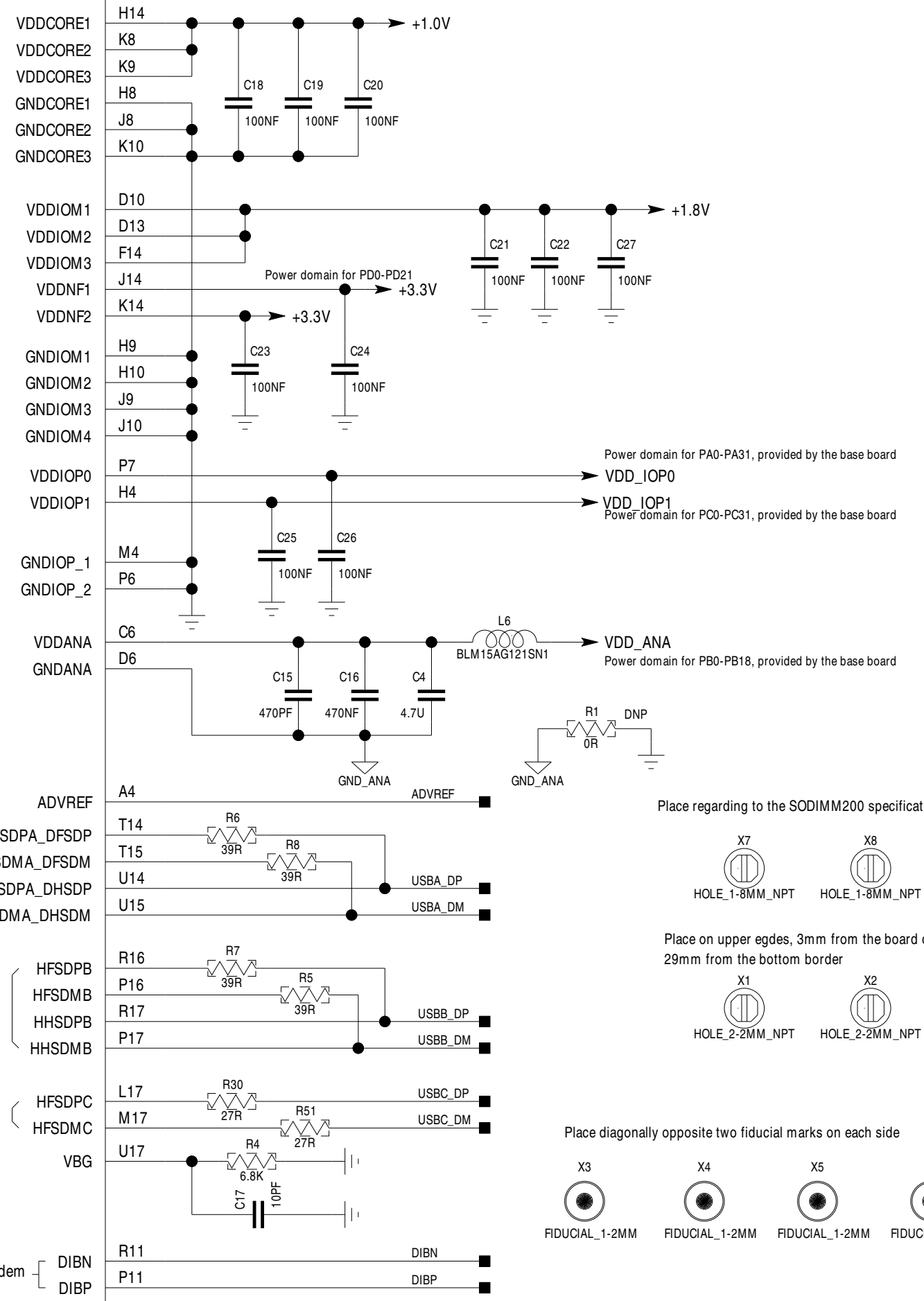

Title: RNETIX - SAM9x5-CM		
Size A3	Document: CPU - POWER SUPPLY	Rev. 2.1
Date: 9-23-2011_14:36	Sheet 1 of 7	

U1

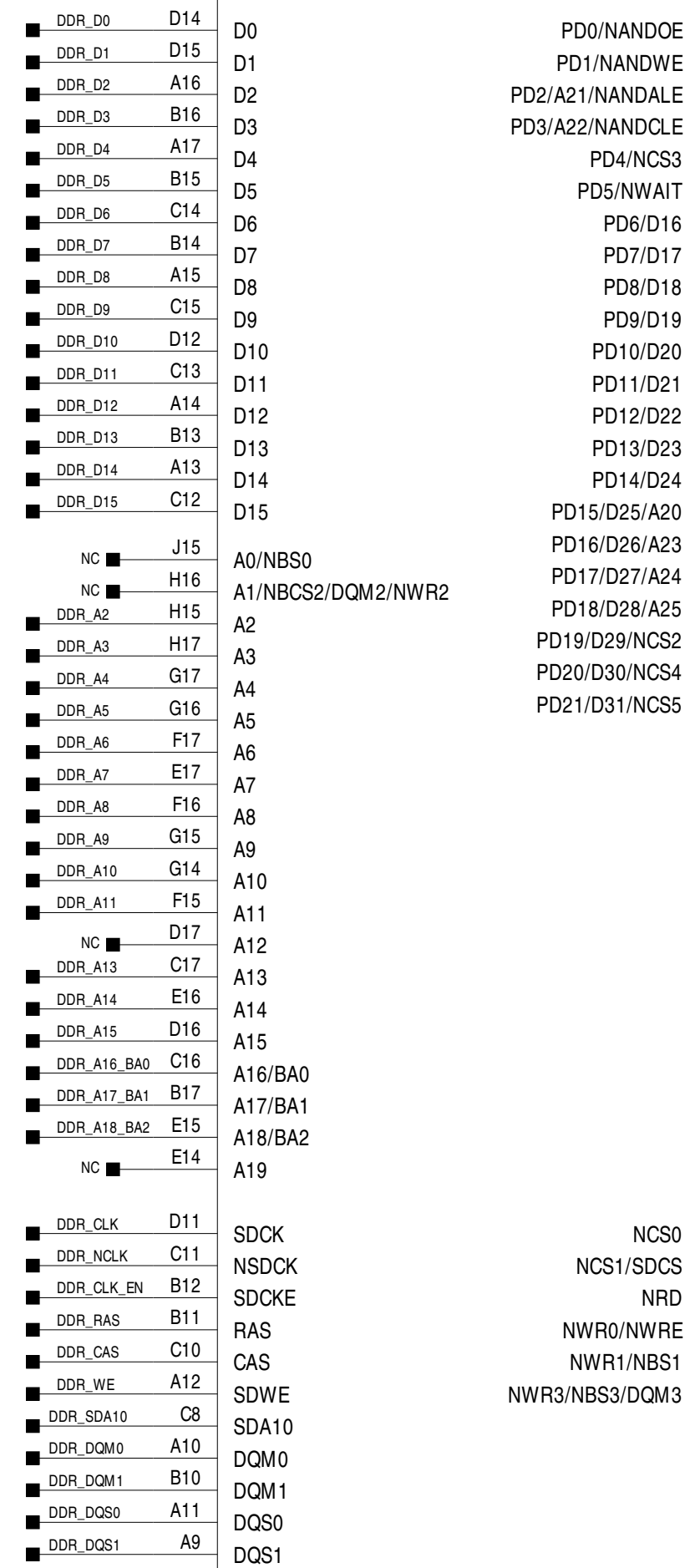

AT91SAM9x5

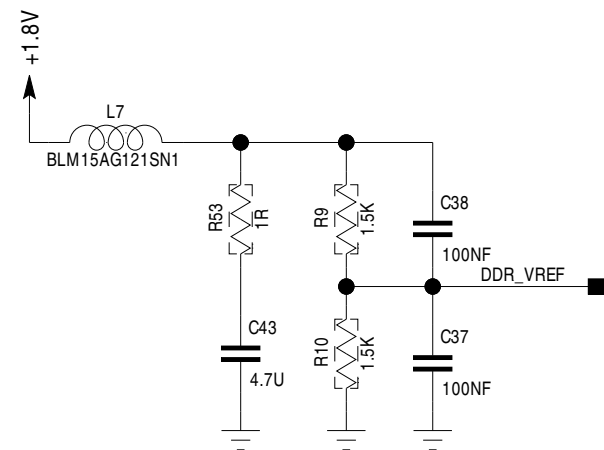
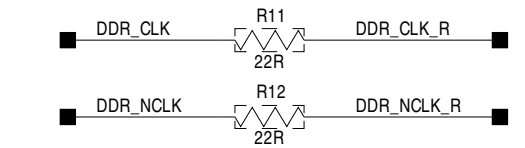
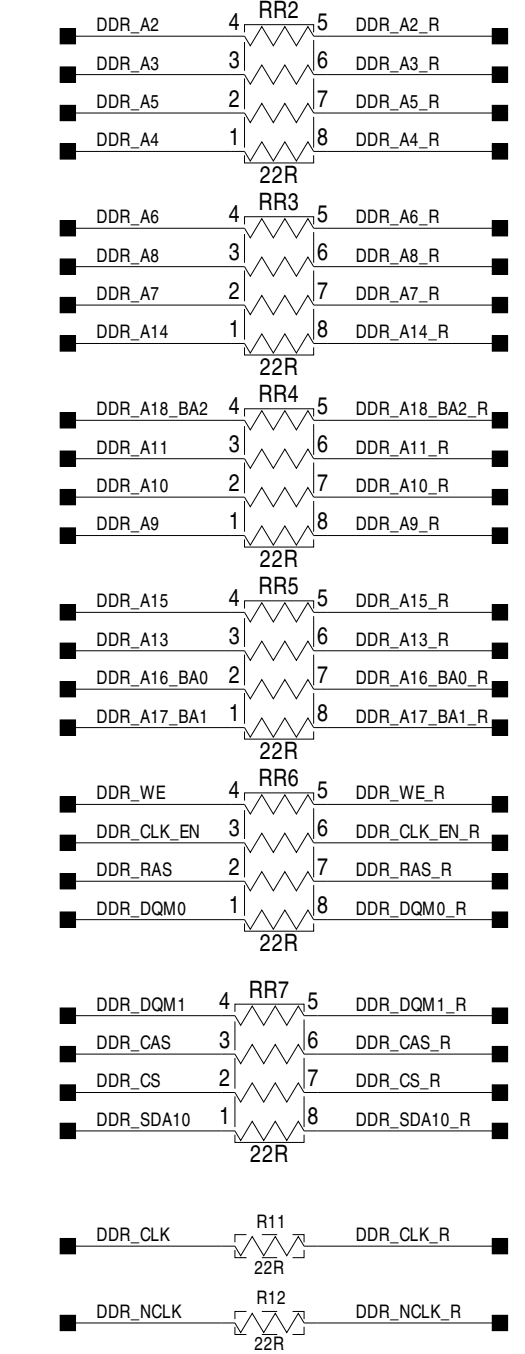
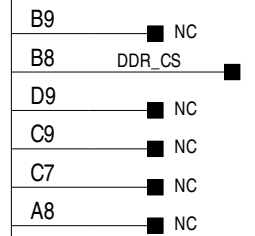
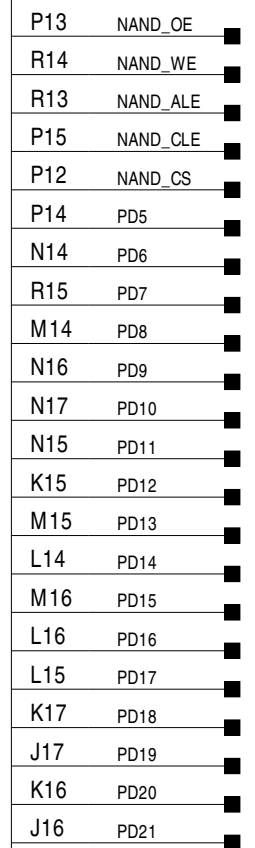

U4

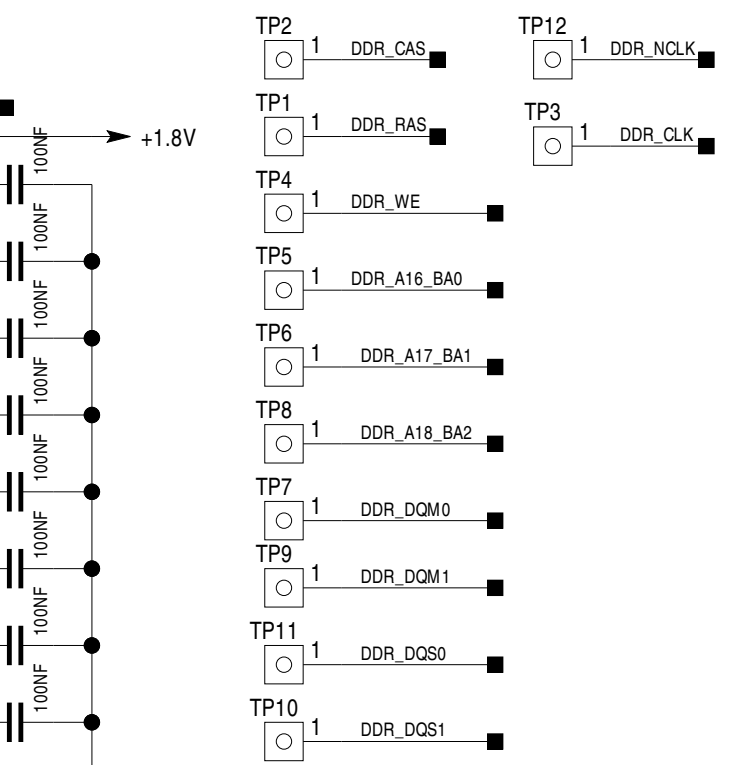
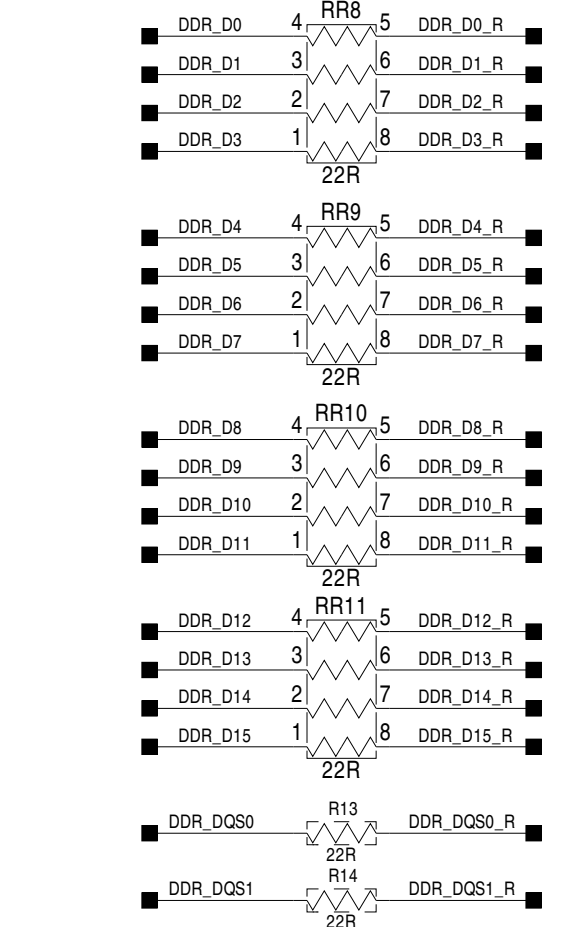
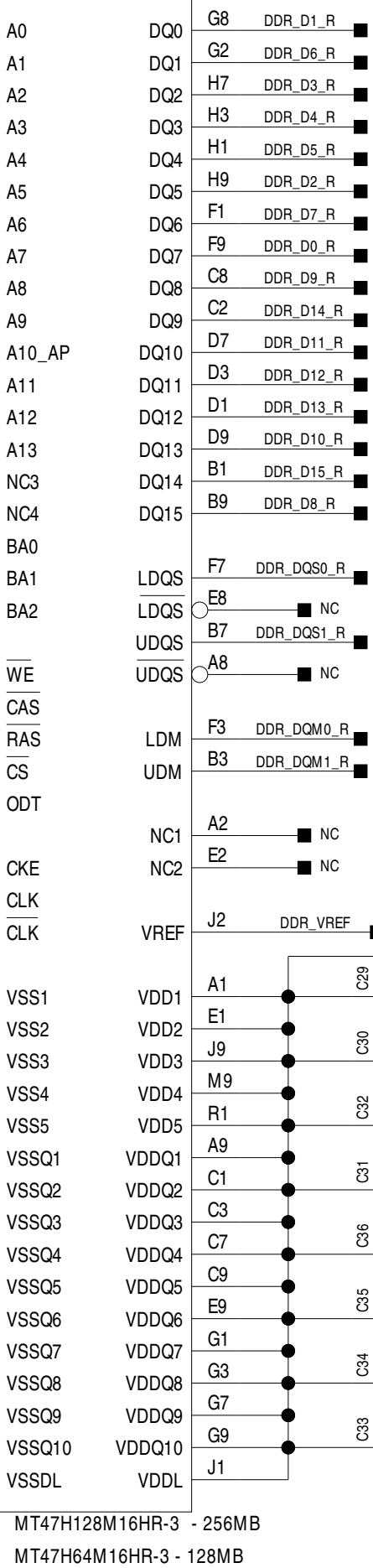
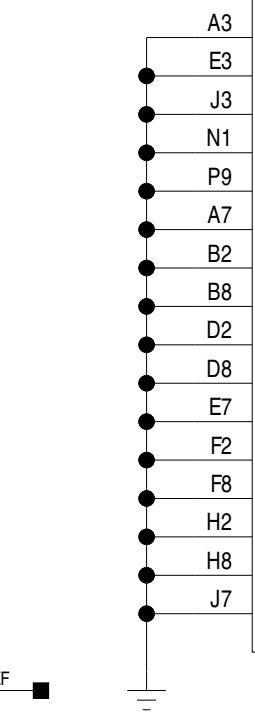
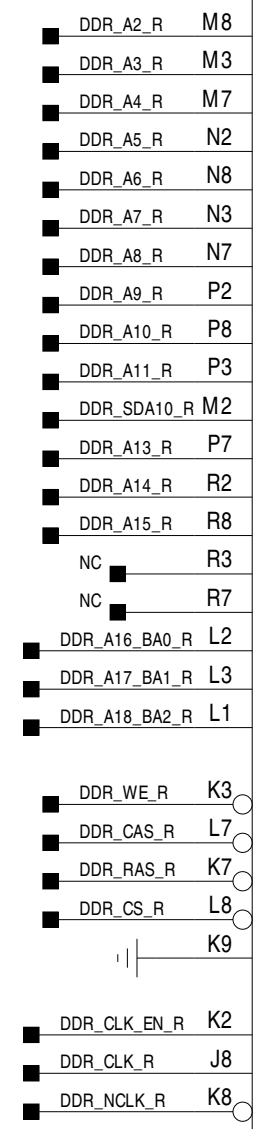

U1

PA0	L3	PA0/TXD0/SPI1_NPCS1	PB0/E0_ERX0/RTS2	D3	PB0
PA1	P1	PA1/RXD0/SPI0_NPCS2	PB1/E0_ERX1/CTS2	D4	PB1
PA2	L4	PA2/RTS0/MCI1_DA1/E0_ETX0	PB2/E0_ERXER/SCK2	D2	PB2
PA3	N4	PA3/CTS0/MCI1_DA2/E0_ETX1	PB3/E0_ERXDV/SPI0_NPCS3	E4	PB3
PA4	T3	PA4/SCK0/MCI1_DA3/E0_ETXER	PB4/E0_ETXCK/TWD2	D1	PB4
PA5	R1	PA5/TXD1/CANTX1	PB5/E0_EMDIO/TWCK2	E3	PB5
PA6	R4	PA6/RXD1/CANRX1	PB6/AD7/E0_EMDC	B3	PB6
PA7	R3	PA7/TXD2/SPI0_NPCS1	PB7/AD8/E0_ETXEN	C2	PB7
PA8	P4	PA8/RXD2/SPI1_NPCS0	PB8/AD9/E0_ETXER	C5	PB8
PA9	U3	PA9/DRXD/CANRX0	PB9/AD10/E0_ETX0/PCK1	C1	PB9
PA10	T1	PA10/DTXD/CANTX0	PB10/AD11/E0_ETX1/PCK0	B2	PB10
PA11	U1	PA11/SPI0_MISO/MCI1_DA0	PB11/AD0/E0_ETX2/PWM0	A3	PB11
PA12	T2	PA12/SPI0_MOSI/MCI1_CDA	PB12/AD1/E0_ETX3/PWM1	B4	PB12
PA13	T4	PA13/SPI0_SPCK/MCI1_CK	PB13/AD2/E0_ERX2/PWM2	A2	PB13
PA14	U2	PA14/SPI0_NPCS0	PB14/AD3/E0_ERX3/PWM3	C4	PB14
PA15	U4	PA15/MCIO_DA0	PB15/AD4/E0_ERXCK	C3	PB15
PA16	P5	PA16/MCIO_CDA	PB16/AD5/E0_ECRS	A1	PB16
PA17	R5	PA17/MCIO_CK	PB17/AD6/E0_ECOL	B1	PB17
PA18	U5	PA18/MCIO_DA1	PB18/IRQ/ADTRG	D5	PB18
PA19	T5	PA19/MCIO_DA2		E2	PC0
PA20	U6	PA20/MCIO_DA3	PC0/LCDDAT0/ISI_D0/TWD1	F4	PC1
PA21	T6	PA21/TIOA0/SPI1_MISO	PC1/LCDDAT1/ISI_D1/TWCK1	F3	PC2
PA22	R6	PA22/TIOA1/SPI1_MOSI	PC2/LCDDAT2/ISI_D2/TIOA3	H2	PC3
PA23	U7	PA23/TIOA2/SPI1_SPCK	PC3/LCDDAT3/ISI_D3/TIOB3	E1	PC4
PA24	T7	PA24/TCLK0/TK	PC4/LCDDAT4/ISI_D4/TCLK3	G4	PC5
PA25	T8	PA25/TCLK1/TF	PC5/LCDDAT5/ISI_D5/TIOA4	F2	PC6
PA26	R7	PA26/TCLK2/TD	PC6/LCDDAT6/ISI_D6/TIOB4	F1	PC7
PA27	P8	PA27/TIOB0/RD	PC7/LCDDAT7/ISI_D7/TCLK4	G1	PC8
PA28	U8	PA28/TIOB1/RK	PC8/LCDDAT8/ISI_D8/UTXD0	G3	PC9
PA29	R9	PA29/TIOB2/RF	PC9/LCDDAT9/ISI_D9/URXD0	G2	PC10
PA30	R8	PA30/TWD0/SPI1_NPCS3/E0_EMDC	PC10/LCDDAT10/ISI_D10/PWM0	H3	PC11
PA31	U9	PA31/TWCK0/SPI1_NPCS2/E0_ETXEN	PC11/LCDDAT11/ISI_D11/PWM1	J3	PC12
			PC12/LCDDAT12/ISI_PCK/TIOA5	L2	PC13
			PC13/LCDDAT13/ISI_VSYNC/TIOB5	H1	PC14
			PC14/LCDDAT14/ISI_HSYNC/TCLK5	J2	PC15
			PC15/LCDDAT15/ISI_MCK/PCK0	J1	PC16
			PC16/LCDDAT16/E1_RXER/UTXD1	L1	PC17
			PC17/LCDDAT17/URXD1	K2	PC18
			PC18/LCDDAT18/E1_TX0/PWM0	N3	PC19
			PC19/LCDDAT19/E1_TX1/PWM1	K1	PC20
			PC20/LCDDAT20/E1_RX0/PWM2	M3	PC21
			PC21/LCDDAT21/E1_RX1/PWM3	P3	PC22
			PC22/LCDDAT22/TXD3	J4	PC23
			PC23/LCDDAT23/RXD3	K3	PC24
			PC24/LCDDISP/RTS3	M2	PC25
			PC25/CTS3	P2	PC26
			PC26/LCDPWM/SCK3	M1	PC27
			PC27/LCDVSYNC/E1_TXEN/RTS1	K4	PC28
			PC28/LCDHSYNC/E1_CRSDV/CTS1	N1	PC29
			PC29/LCDDEN/E1_TXCK/SCK1	R2	PC30
			PC30/LCDPCK/E1_MDC	N2	PC31
			PC31/FIQ/E1_MDIO/PCK1		

AT91SAM9x5

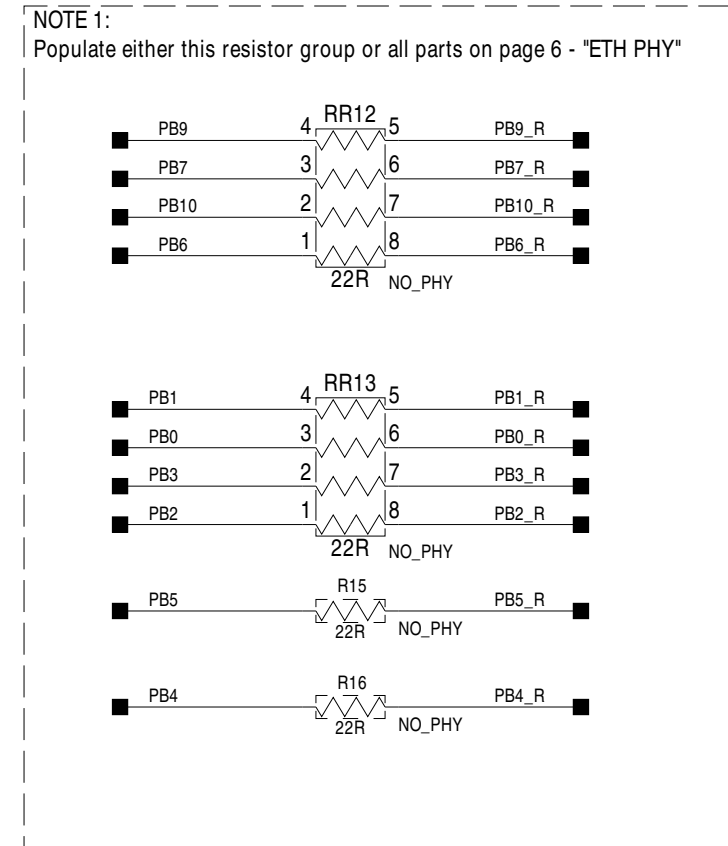

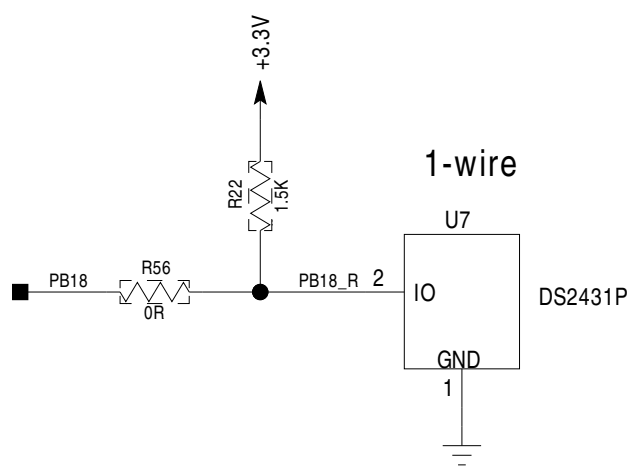
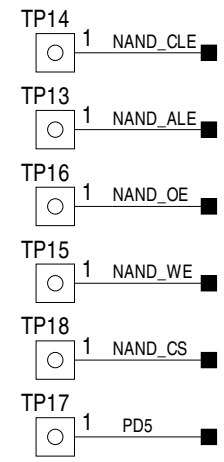

NAND Flash

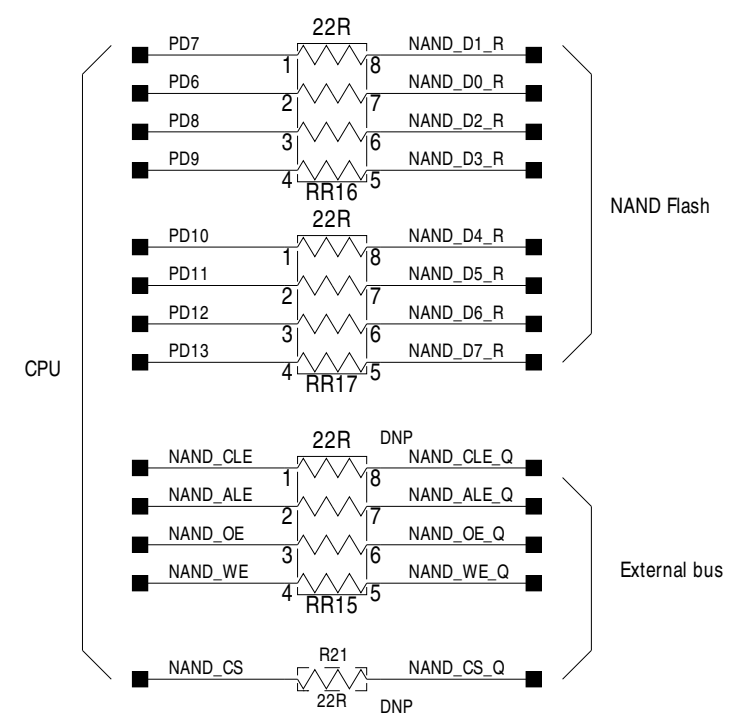
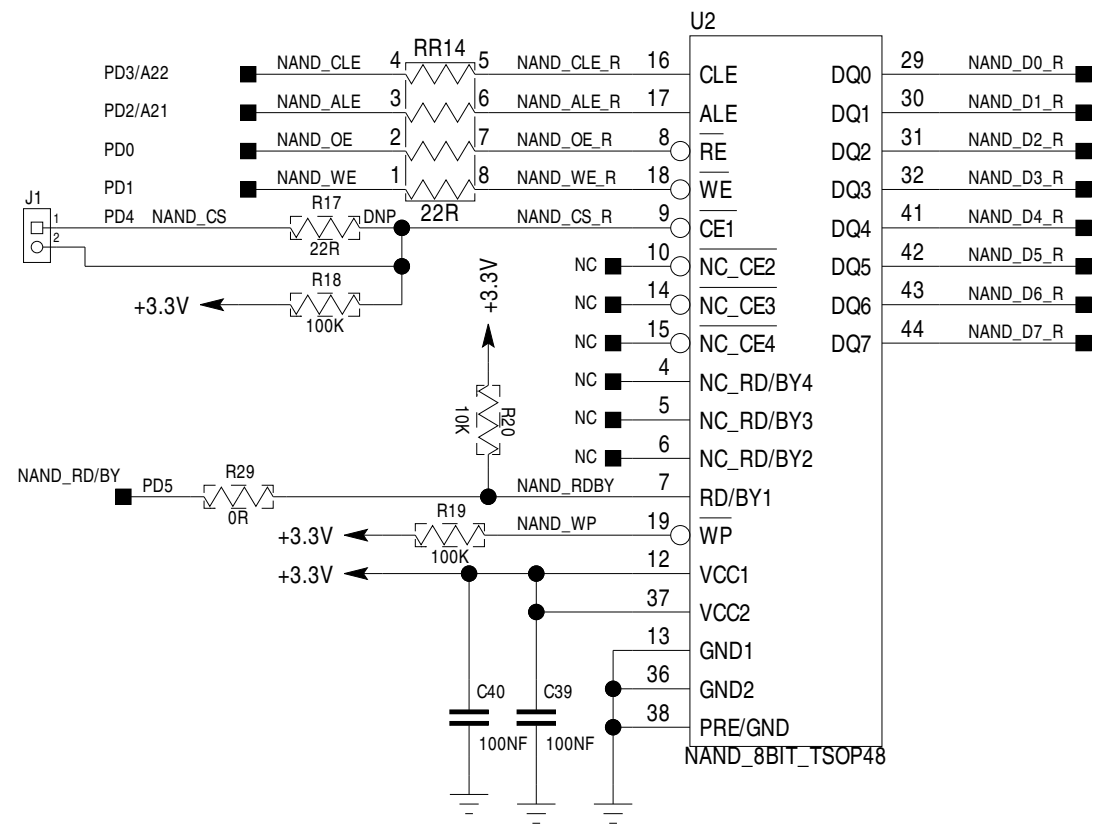

I2C EEPROM

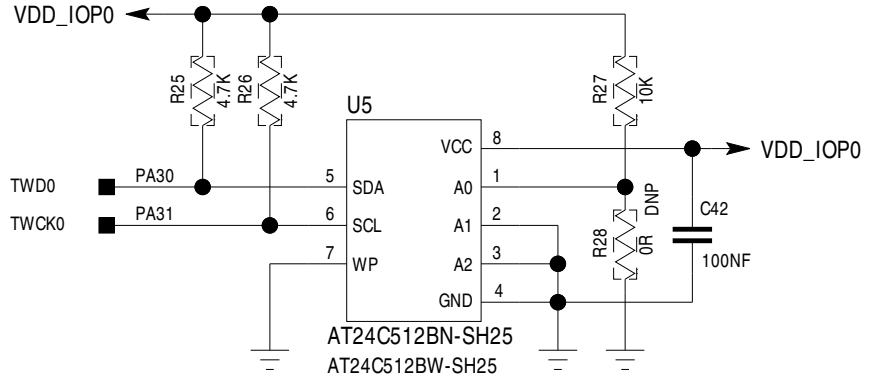

SPI Serial Flash

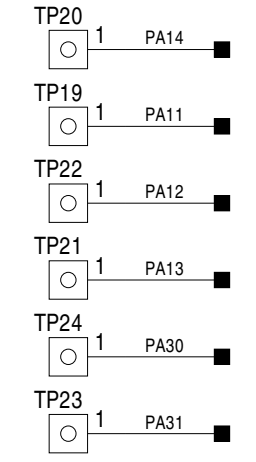
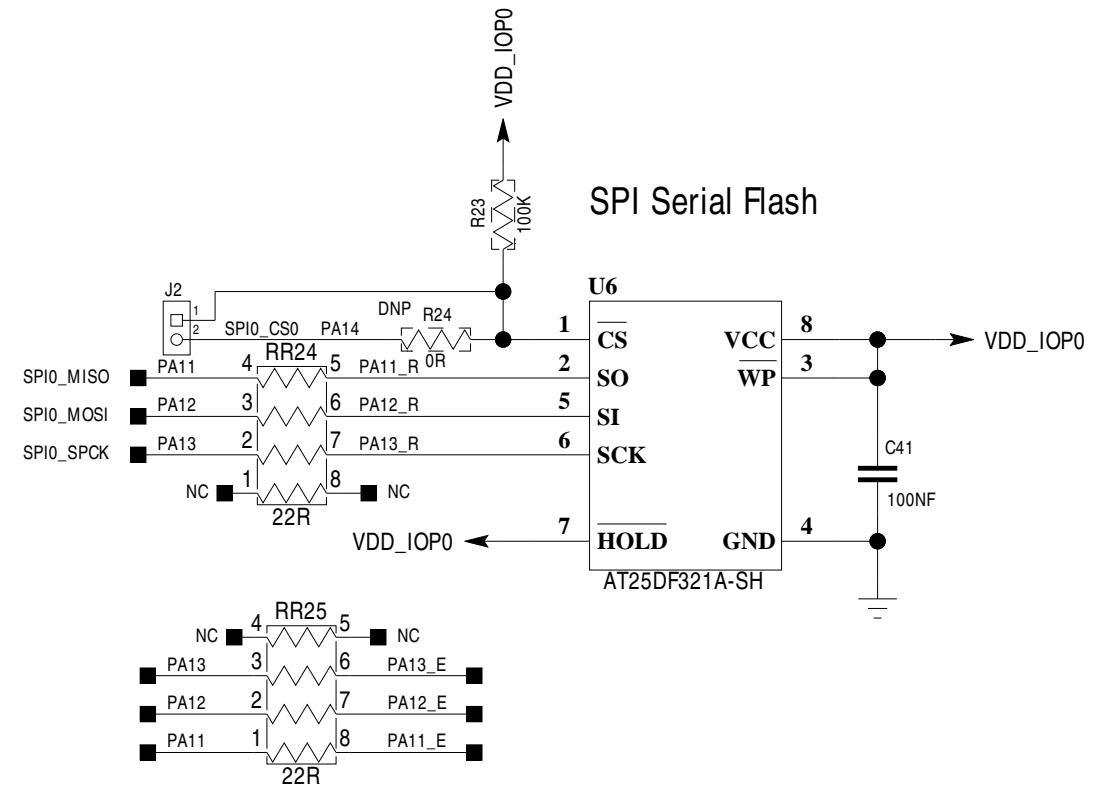

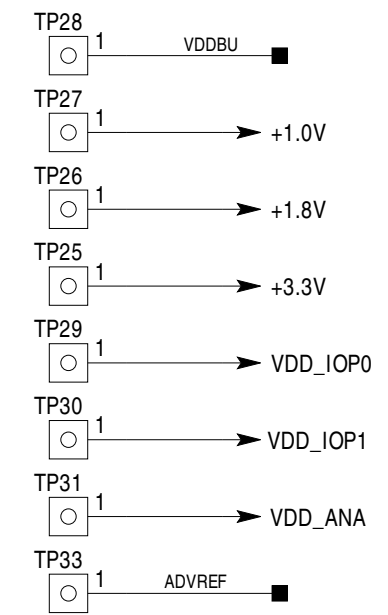
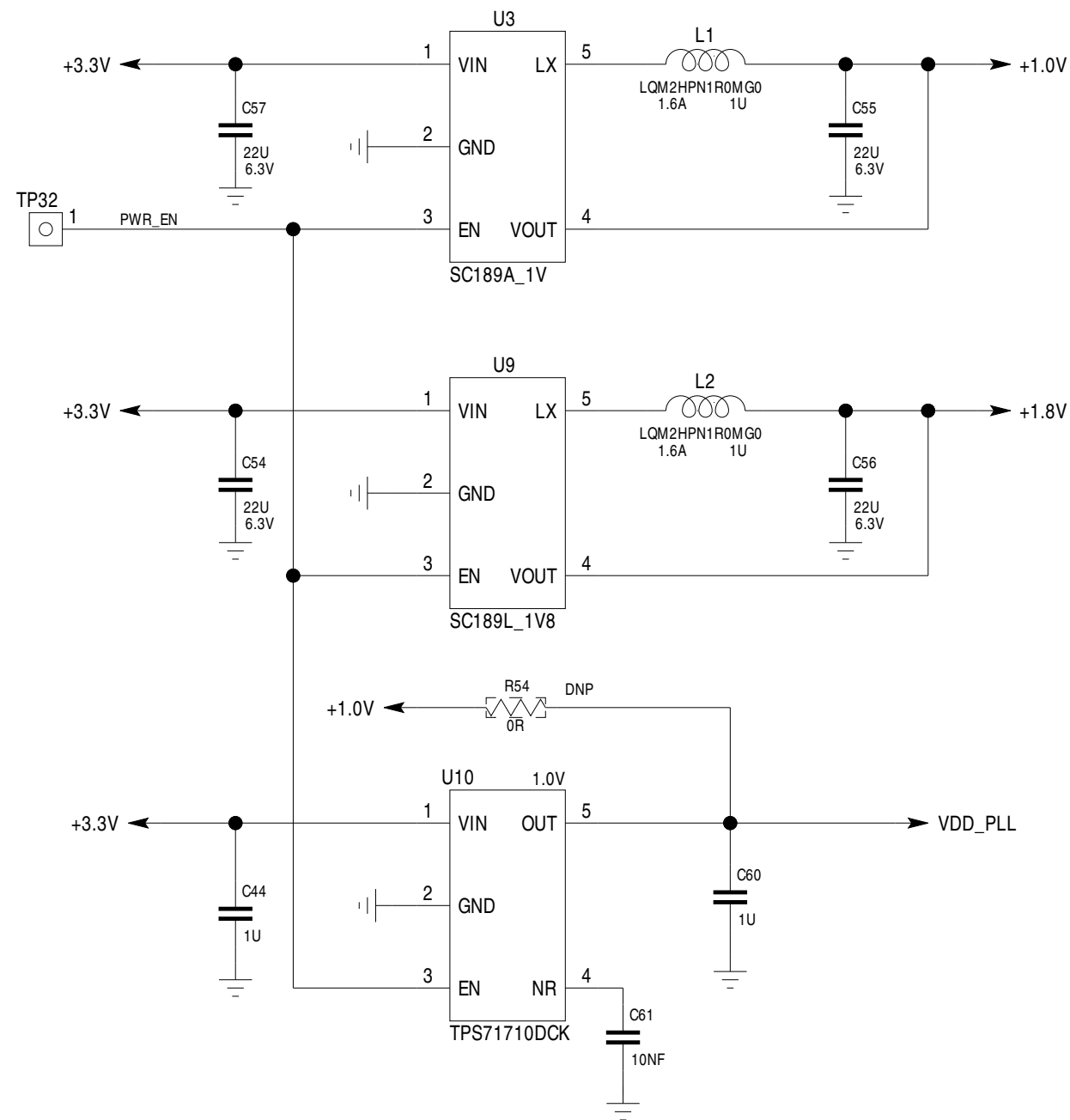

User LEDs

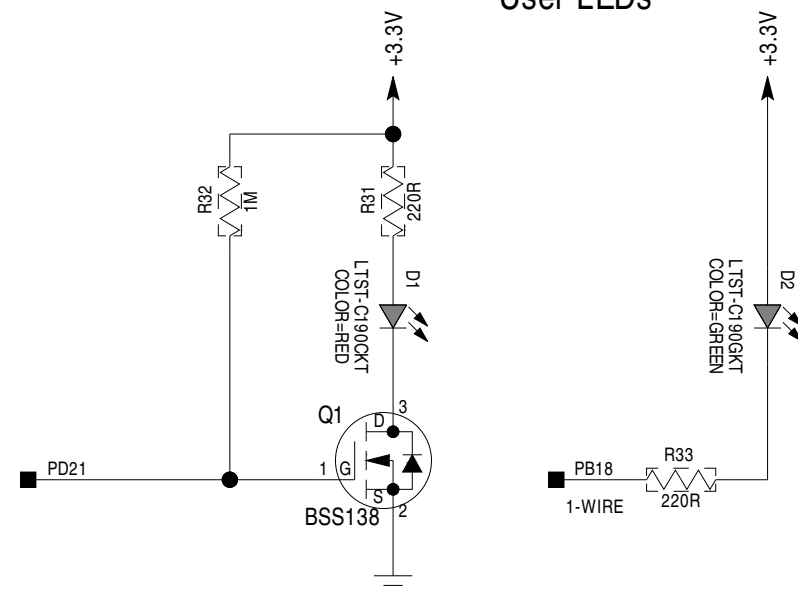

Title: RONETIX - SAM9x5-CM		
Size A3	Document: POWER SUPPLY	Rev. 2.1
Date: 9-23-2011_12:36	Sheet 5 of 7	

Ethernet PHY 10/100, RMII

NOTE 2:
Populate either all parts on this page or the resistor group on page 3

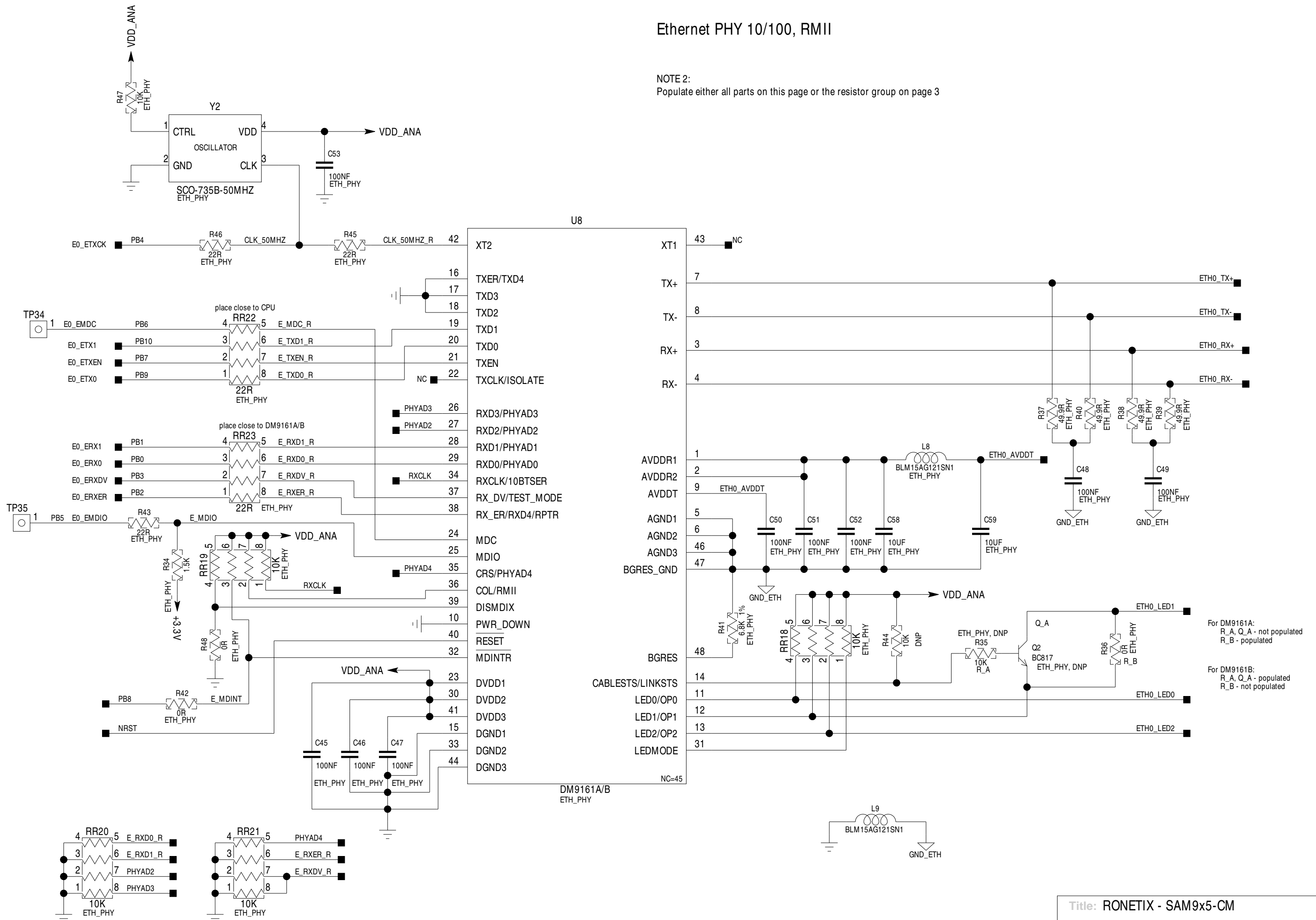

Front Side Back Side

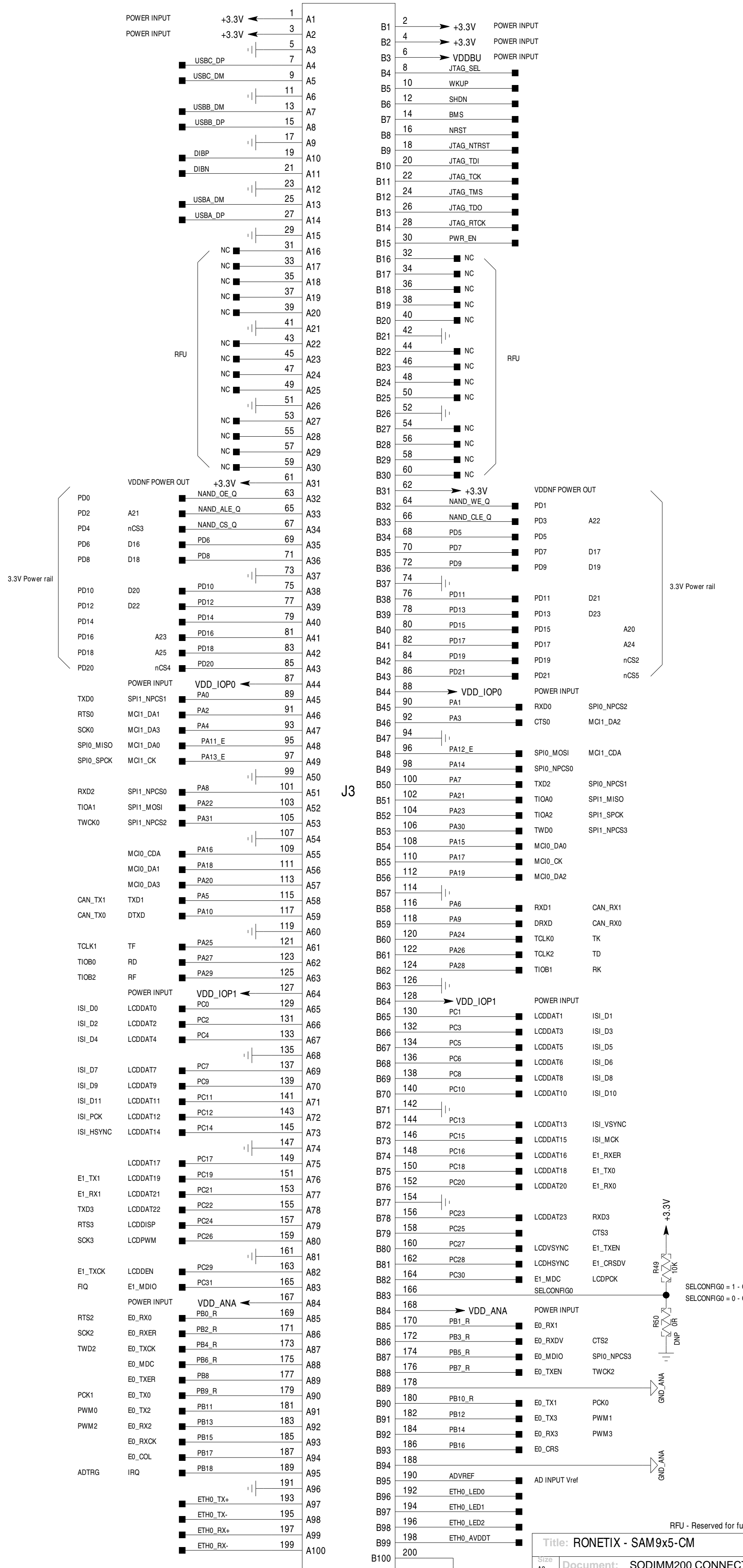

RFU - Reserved for future use

Title: RNETIX - SAM9x5-CM

Size A3	Document: SODIMM200 CONNECTOR	Rev. 2.1
Date: 9-23-2011_12:36	Sheet 7 of 7	