

---

***«NPF Mechatronica-Pro» LTD***

***MChip176-28335 – Developer's module  
for processors TMS320F2833x and TMS320F2823x  
with ZIF-panel***

---

Technical manual

Rev. 1.00

This technical manual corresponds to developer's module MChip176-28335 rev. 1.00. Correspondance of this manual to other versions of the module should be specified on website of developer – «NPF Mechatronica-Pro» LTD – [www.mechatronica-pro.com](http://www.mechatronica-pro.com).

## 1. Purpose

Developer's module MChip176-28335 is a debugging board with ZIF-panel and integrated USB-programmer for microcontrollers TMS320F28332, TMS320F28334, TMS320F28335, TMS320F28232, TMS320F28234, TMS320F28235 manufactured by Texas Instruments. In base case system the module is supplied with most advanced microcontroller of the line - TMS320F28335.

The module is intended for developing and debugging software that is developed for microcontrollers TMS320F2833x, TMS320F2823x, as well as for programming and testing chips built on their basis.

The module can be used as a processor board for various laboratory and debugging kits, for example, from MCB line manufactured by «NPF Mechatronica-Pro» LTD.

The module is delivered with real-time operational environment MexBIOS™ and graphical programming environment MexBIOS™ Development Studio pre-installed into Flash-memory of the processor, and the environments use essentially accelerates the development of the software.

Mounting holes and location of main input-output connectors of module MChip176-28335 correspond to debugging board eZdsp™2812 manufactured by Spectrum Digital that in many cases makes them interchangeable.

Physical configuration of the module is shown in fig. 1.

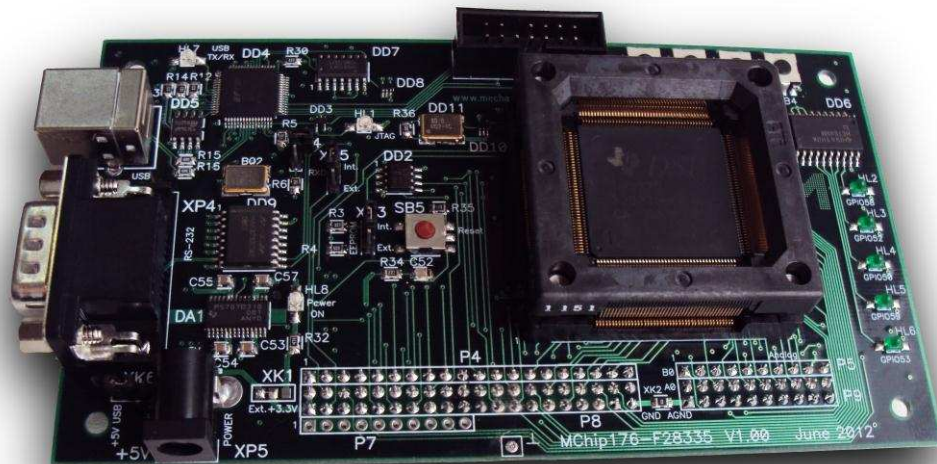

Fig. 1. Physical configuration of the developer's module MChip176-28335

## 2. Specification

Main specification of module MChip176-28335 is shown in table 1.

Table 1. Specification of module MChip176-28335		
Processor mounting method	ZIF- panel with zero insertion force	
Processor package	LQFP 176 (PGF)	
Processor	TMS320F28335	
Mountable processors	TMS320F28332, TMS320F28334, TMS320F28335, TMS320F28232, TMS320F28234, TMS320F28235	
Clock frequency	Up to 150 MHz	
Floating point module FPU	Yes	
Memory on processor chip	For TMS320F28335	
RAM		34K x 16
Flash		256K x 16
Digital input/output lines, total	88	
EEPROM on board	64 kB (8k x 8)	
To external connections are led:		
analog inputs of the microcontroller	2 x 8 (12-bit ADC)	
digital inputs/outputs of the microcontroller	43 (3,3 V logic)	
Buttons for testing input	4	
LEDs for testing output	5	
Programming	Integrated USB-programmer (XDS100 deiver) Connector IEEE 1149.1 JTAG	
Interface facilities of the board	USB 2.0 (VCP) and RS-232 connected to SCI MK interface	
Embedded software	Pre-installed OS MexBIOS™	
Power supply	From external power source 5 V 0,5 A From USB	
Board dimensions, mm	136,1 x 76,5	



### 3.2. Location of components on the board

Location of components on the board can be seen in fig. 3.

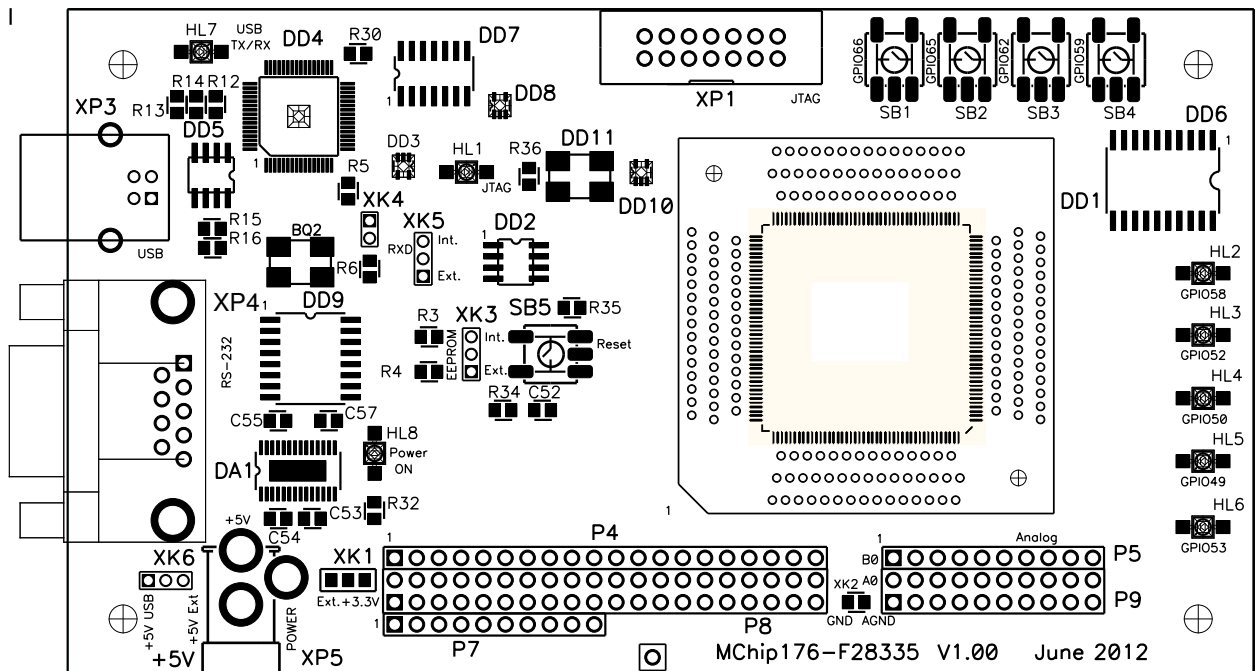

a) top view

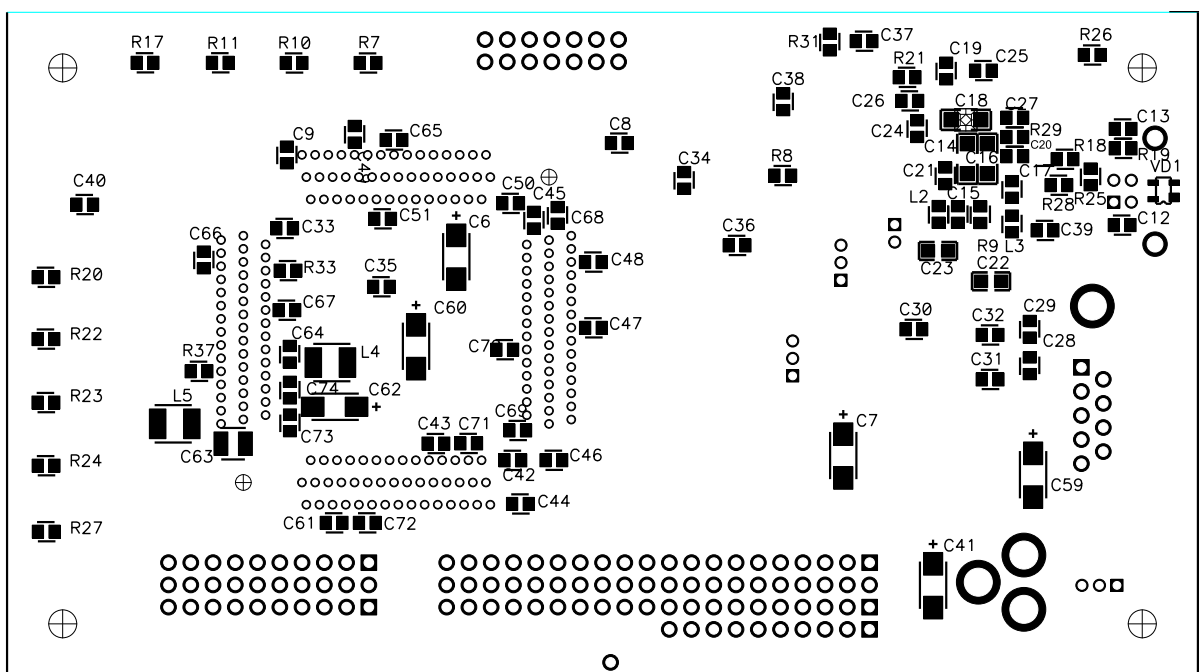

b) bottom view

Fig. 3. Location of components on board of module MChip176-28335

### 3.3. Connectors functions

Functions of the module connectors are shown in table 2.

Table 2. Functions of connectors of the module				
Designation	Function		Type of on-board connector	Type of complementary connector
XP1	JTAG	Programming and debugging	BH-14	PBD-14, IDC-14F
XP3	USB	a) virtual COM-port (VCP), б) programming interface JTAG	Port USB type B	Socket USB type B
XP4	RS-232	Последовательный интерфейс	DRB-9MB	DB-9F, DI(C)-9F
XP5	+5 V	External power supply	DJK-02A	DJK-10A
P4, P7, P8		Logic signal interface	PBD, PBS	PLT, PLD, PLS
P5, P9		Analog signals	PBD, PBS	PLT, PLD, PLS

### 3.4. Jumpers functions

Functions of the module jumpers are shown in table 3.

Table 3. Functions of jumpers of the module	
Designation	Function
XK1	Выбор напряжения питания внешних цепей через разъёмы P4, P8
XK2	Соединение аналоговой и цифровой земель
XK3	Выбор используемой микросхемы памяти EEPROM
XK4	Сброс драйвера USB
XK5	Выбор источника сигнала SCI RxD
XK6	Выбор источника питания модуля

### 3.5. LEDs functions

Functions of the module LEDs are shown in table 4.

Table 4. Functions of LEDs of the module			
Designation		Color	Function
HL1	JTAG	yellow	Indication of JTAG operation
HL2	GPIO58	green	Testing digital output, active level – high level
HL3	GPIO52		
HL4	GPIO50		
HL5	GPIO49		
HL6	GPIO53		
HL7	USB TX/RX	yellow	Indication of the data exchange via virtual COM-port USB
HL8	Power ON	red	Indication of power supply +3,3 V

### 3.6. Buttons functions

Functions of the module buttons are shown in table 5.

Table 5. Functions of buttons of the module		
Designation		Function
SB1	GPIO66	Testing digital input. If the button is pushed, the input gets logic zero state
SB2	GPIO65	
SB3	GPIO62	
SB4	GPIO59	
SB5	Reset	Reset of the microcontroller by switching off power

### 3.7. EEPROM memory usage

#### 3.7.1. EEPROM memory

For long-term data storage a nonvolatile memory chip CAT25640 (DD2) with capacity of 64K and feature (8192 x 8) is mounted on the module.

The memory communicates data with microcontroller via SPI interface, by using SPI A module of the microcontroller. The crystal selection signal is generated by GPIO40 line (SPI\_CS1 signal, the active level is low).

#### 3.7.2. Jumper XK3 function

The microcontroller can use non-volatile data memory both the mounted on the module (DD2) and external one depending on setting of jumper XK3 that controls the crystal selection.

Table 6. Jumper XK3 settings		
Jumper	Setting	EEPROM chip in use
XK3	«Int» (upper)*	Mounted on the module
	«Ext» (lower)	External

Setting «Int» of jumper XK3 corresponds to the use of memory chip mounted on the module. When the jumper is set to «Ext», the microcontroller calls to external memory chip via connectors P4, P8.

#### 3.7.3. SPI bus of the module

SPI bar of the module is connected to the microcontroller pins according to table 7.

Table 7. Signals of SPI bus of the module			
Microcontroller pin	GPIO	Signal	External connector
96	GPIO54	SPISIMOA	P8: 23
97	GPIO55	SPISOMIA	P8: 24
98	GPIO56	SPICLKA	P8: 25
99	GPIO57	~SPISTE A	P8: 26
148	GPIO35	SPI_CS0	P4: 3
151	GPIO40	SPI_CS1	P4: 4 (via XK3)
157	GPIO44	SPI_CS2	P4: 5

### 3.8. Power supply of the module

For operation the module needs a power supply with 5 V voltage.

#### 3.8.1. Methods of powering the module

The module power supply can be carried out by three methods:

- via power connector XP5 of type DJK-02A with internal pin with diameter 2 mm, when jumper XK6 is set into «+5 V Ext»;
- via pins 1 (1, 2) of connector P4 (P8), when XK1 jumper is set in 2-3;
- от шины USB при нахождении перемычки XK6 в положении «+5 V USB».

#### 3.8.2. Function of jumper XK1

Setting of planar jumper XK1 determines connection of pin 1 of connector P4 and pins 1, 2 of connector P8 to bus +5 V of the module or to bus +3,3 V. In the former case it is possible to power the module both from an external power source via connectors P4, P8, and powering the boards that are connected to these connectors. In the latter case – the connectors are powered by voltage +3,3 V from the module power supply.

**Table 8. Jumper XK1 setting**

Jumper	Setting	Power supply to P4, P8
XK1	«3.3 V» (right)	+3,3 V
	«5V» (left)*	+5 V
	No jumper	is not applied

#### 3.8.3. Function of jumper XK6

Setting of XK6 jumper determines selection of the module power supply +5 V.

When set to 1-2 «+5 V USB» the module is supplied from USB bus.

When set to 2-3 «+5 V Ext» the module is powered from pin power supply connector XP5 or via pins 1 (1, 2) of connector P4 (P8).

**Table 9. Jumper XK6 setting**

Jumper	Setting	Power supply to the module
XK6	«+5 V USB» (upper)	USB bus
	«+5 V Ext» (lower)*	External supply source +5 V
	No jumper	The module is not powered

### 3.9. Serial interfaces of the module

The module communication with external devices can be carried out by one of two serial interfaces: USB and RS-232.

#### 3.9.1. USB interface

As USB driver a FT2232H chip is used, whose *B* converter converts the signals of USB 2.0 HS into UART with data communication speed up to 12 Mbaud.

The process of data communication is indicated by yellow LED HL7 «USB TX/RX».

The module can be powered from USB bus up to 500 mA.

On the module an USB port of type B (XP3) is mounted. Functions of the connector pins are shown in table 10.

Table 10. Functions of pins of connector XP3		
Connector	Pin	Circuit
XP3 USB port, B type	1	+ 5 V
	2	DP
	3	DM
	4	GND

### 3.9.2. RS-232 interface

As a driver for RS-232 interface a chip MAX3232WE is used with data communication speed up to 1 Mbaud.

For cable connection a connector of type DB-9 (XP4) is used. The connector pins functions are shown in table 11.

Table 11. Functions of pins of connector XP4		
Connector	Pin	Circuit
XP4 DRB-9MB	1	is not used
	2	RxD
	3	TxD
	4	is not used
	5	GND
	6...9	is not used

### 3.9.3. Multiplexing signals

Signals of interfaces are connected to SCI lines of microcontroller via multiplexor that is controlled by signal “~Suspend” of USB driver. If there is no device connected to USB, the USB driver switches over to sleep mode and enables the data communication via RS-232 interface. And vice-versa, activation of USB driver disables the communication via RS-232 interface.

### 3.9.4. Function of jumper XK5

By means of jumper XK5 you can select the source of signal that comes to input SCIRXDA/GPIO28 of microcontroller: from pin of connector P8 or from active driver of serial interface of the module.

Table 12. Jumper XK5 settings		
Jumper	Setting	Signal source for input SCIRXDA
XK5	«Ext» (lower)	From pin 4 of connector P8
	«Int» (upper)*	From driver of serial interface of the board
	No jumper	Signal is not applied to the input

### 3.9.5. SCI bus of the module

SCI bus of the module is connected to pins of microcontroller according to table 13.

**Table 13. Signals of the module SCI bus**

Microcontroller pin	GPIO	Signal	External connector
2	GPIO29	SCITXDA	P8: 3
141	GPIO28	SCIRXDA	P8: 4 (via XK5)

### 3.10. Programming via JTAG

Programming and debugging of the software can be fulfilled by means of JTAG interface via connector XP1 and via USB converter.

#### 3.10.1. Programming via USB

Converter A of the USB driver - chip FT2232H converts signals of USB 2.0 HS into JTAG interface, if XDS100 driver is used on the computer.

The process of data communication is indicated by yellow LED HL1 «JTAG».

#### 3.10.2. Programming via connector XP1

Functions of the connector pins are shown in table 14.

**Table 14. Functions of pins of connectors XP1, XS1**

Connector	Pin	Circuit
XP1, PBD-14	1	TMS
	2	~TRST
	3	TDI
	4	GND
	5	+3.3 V
	6	GND
	7	TDO
	8	GND
	9	TCK
	10	GND
	11	TCK
	12	GND
	13	EMU0
	14	EMU1/~OFF

### 3.11. Connectors of inputting/outputting logic signals

Inputting/outputting logic signals from microcontroller to external expansion boards is carried out via connectors P4, P7, P8.

Almost all outputs of the connectors are connected directly to microcontroller and allow operation with 3,3 V.

Functions of the connectors pins are shown in table 15.

Table 15. Functions of pins of connectors P4, P7, P8

Connector	Pin	Microcontroller pin			Function in set/module
		№	Functions	GPIO	
P4, PBS-20	1				+5V
	2				
	3	148	SCITXDA	GPIO35	SPI_CS0
	4	151		GPIO40	SPI_CS1 (XK3)
	5	157		GPIO44	SPI_CS2
	6	163		GPIO80	
	7	169		GPIO84	
	8	172		GPIO85	
	9	175		GPIO39	
	10				GND
	11	174		GPIO87	KEY_C2
	12	27	SPISIMOA/CANTXB/~TZ5	GPIO16	KEY_C3
	13	24	TZ2/CANRXB/MDRB	GPIO13	KEY_L1
	14	26	~TZ4/~XHOLDA/SCIRXDB/MFSXB	GPIO15	KEY_L2
	15				
	16				
	17	1	CANRXA	GPIO30	
	18	28	SPISOMIA/CANRXB/~TZ6	GPIO17	
	19	25	~TZ3/~XHOLD/SCITXDB/MCLKXB	GPIO14	
	20				GND
P7, PBS-10	1				
	2				
	3				
	4				
	5				
	6				
	7				
	8				
	9	88		GPIO48	
	10				GND
P8, PBD-40	1				+5V
	2				+5V
	3	2	SCITXDA	GPIO29	SCITXDA
	4	141	SCIRXDA/~XZCS6	GPIO28	SCIRXDA (XK5)
	5				
	6	64	EQEP1A/MDXA/CANTXB	GPIO20	CAP1_QEP1
	7	65	EQEP1B/MDRA/CANRXB	GPIO21	CAP1_QEP2
	8	67	EQEP1I/MFSXA/SCIRXDB	GPIO23	CAP3_QEP1
	9	5	EPWM1A	GPIO0	PWM1
	10	6	EPWM1B/ECAP6/MFSRB	GPIO1	PWM2
	11	7	EPWM2A	GPIO2	PWM3
	12	10	EPWM2B/ECAP5/MCLKRB	GPIO3	PWM4
	13	11	EPWM3A	GPIO4	PWM5
	14	12	EPWM3B/MFSRA/ECAP1	GPIO5	PWM6

**Table 15 (Continuation). Functions of pins of connectors P4, P7, P8**

Connector	Pin	Microcontroller pin			Function in set/module
		№	Functions	GPIO	
P8, PBD-40	15	73	ECAP4/EQEP2S/MFSXB	GPIO27	BRAKE
	16	72	ECAP3/EQEP2I/MCLKXB	GPIO26	CHARGE
	17				
	18				
	19				GND
	20				GND
	21				
	22				
	23	96	SPISIMOA	GPIO54	SPISIMOA
	24	97	SPISOMIA	GPIO55	SPISOMIA
	25	98	SPICLKA	GPIO56	SPICLKA
	26	99	~SPISTEА	GPIO57	SPISTEA
	27	69	ECAP2/EQEP2B/MDRB	GPIO25	EN_PWM1
	28	68	ECAP1/EQEP2A/MDXB	GPIO24	EN_PWM2
	29				
	30	13	EPWM4A/EPWMSYNCI/ EPWMSYNCO	GPIO6	PWM7
	31	16	EPWM4B/MCLKRA/ECAP2	GPIO7	PWM8
	32	17	EPWM5A/CANTXB/~ADCSOCAO	GPIO8	PWM9
	33	18	EPWM5B/SCITXDB/ECAP3	GPIO9	PWM10
	34	19	EPWM6A/CANRXB/~ADCSOCBO	GPIO10	PWM11
35	20	EPWM6B/SCIRXDB/ECAP4	GPIO11	PWM12	
36	66	EQEP1S/MCLKXA/SCITXDB	GPIO22	KEY_C1	
37	63	~SPISTEА/SCIRXDB/CANTXA	GPIO19	FAULT1	
38	62	SPICLKA/SCITXDB/CANRXA	GPIO18	FAULT2	
39				GND	
40				GND	

### 3.12. Inputting analog signals

#### 3.12.1. Connectors for inputting analog signals

Inputting analog signals from external expansion boards is carried out via connectors P5, P9. Functions of the connectors pins are shown in table 16.

**Table 16. Functions of pins of connectors P5, P9**

Connector	Pin	Microcontroller pin			Function in MCB kit
		№	Function	Assignment	
P5, PBS-10	1	46	ADCINB0	Analog inputs ADC B	VREF
	2	47	ADCINB1		V_DC
	3	48	ADCINB2		CUR_W1
	4	49	ADCINB3		CUR_U1
	5	50	ADCINB4		
	6	51	ADCINB5		

Таблица 16 (Продолжение). Назначение выводов разъемов P5, P9

Connector	Pin	Microcontroller pin			Function in MCB kit
		№	Function	Assignment	
P5, PBS-10	7	52	ADCINB6		CUR_U2
	8	53	ADCINB7		CUR_W2
	9	55	ADCREFM	Reference voltage 1 V output	
	10	56	ADCREFP	Reference voltage 2 V output	
P9, PBD-20	1				AGND
	2	42	ADCINA0	Analog input ADC A0	
	3				AGND
	4	41	ADCINA1	Analog input ADC A1	
	5				AGND
	6	40	ADCINA2	Analog input ADC A2	
	7				AGND
	8	39	ADCINA3	Analog input ADC A3	
	9				AGND
	10	38	ADCINA4	Analog input ADC A4	
	11				AGND
	12	37	ADCINA5	Analog input ADC A5	
	13				AGND
	14	36	ADCINA6	Analog input ADC A6	
	15				AGND
	16	35	ADCINA7	Analog input ADC A7	
	17				AGND
18	43	ADCLO	Common point of ADC inputs		
19				AGND	
20			<i>is not used</i>		

ADC of the microcontroller has integrated source of reference voltage. It is important to note that the ADCLO pin should be connected to analog ground or to required point of the ADC zero level.

### 3.12.2. Function of jumper XK2

Planar jumper XK2 interconnects analog and digital grounds of the module. In delivery set it is mounted.

## 4. Delivery set

The module is delivered as a set of following components:

- Debugging board MChip80-28035;
- Power supply source ~220 V / + 5 V, 3 A;
- Null-modem cable DB9F-DB9F 3.0m;
- cable USB 2.0 A -->B 1.8m with ferrite rings;
- technical manual;
- pre-installed MexBIOS™Kernel.

Note: for configuring MexBIOS™Kernel you need to contact the developer or download MexBIOS™Development Studio from the website of the developer.

## 5. Contacts

"NPF Mechatronica-Pro" LTD  
str. Usova 7 office 232  
Tomsk 634034 Russia  
Phone.: +7 (3822) 252-842  
E-Mail: [support@mechatronica-pro.com](mailto:support@mechatronica-pro.com)  
<http://mechatronica-pro.com>