



---

## MR16 LED Driver IC – INDICE0002

### with Power and Active Temperature Management

## KEY FEATURES

- Input voltage range: 12 V DC / 12 V AC.
- Input frequency range from DC to 300kHz AC.
- Output power scalable to 20W with the correct selection of switching silicon and magnetic parts.
- Adjustable LED output voltage from 3 to 29V <sup>1</sup>.
- Programmable over-temperature shut down, from 60 to 92 °C.
- Clock-less, asynchronous operation of primary switching reduces EMI test compliance issues.
- Compatible with 12V AC magnetic and electronic transformers.
- Compatible with 12V AC magnetic transformers with leading edge dimmer circuits<sup>1</sup>.
- Compatible with 12V AC electronic transformers with trailing edge dimmer circuits<sup>1</sup>.
- Small module size allows an easy integration into final products.
- Efficiency (Measured in default configuration from MR16 input pins to LED output).
  - Single stage: > 85%.
  - Dual stage: > 80% (Primary and secondary outputs used).

---

<sup>1</sup> Higher output voltages possible with increased voltage rating on certain parts.

#### DISCLAIMER

All intellectual, design, manufacturing, reproduction, use and sale rights regarding this document are expressly reserved by Indice Semiconductor Pty Ltd.. These materials and all of the contents contained herein are provided "AS IS" and Indice Semiconductor Pty Ltd neither assumes nor accepts any liability for any errors or omissions contained in these materials.

# Table of Contents

<b>1 Introduction</b> .....	<b>3</b>
<b>1.1 Overview</b> .....	<b>3</b>
<b>1.2 Chip Benefits</b> .....	<b>3</b>
<b>1.3 System Benefits</b> .....	<b>3</b>
<b>1.4 System Features</b> .....	<b>4</b>
<b>1.5 Suggested Applications</b> .....	<b>4</b>
<b>1.6 Indice Semiconductor Pty Ltd Support Contacts</b> .....	<b>4</b>
<b>1.7 Device Pin Out</b> .....	<b>5</b>
<b>1.8 Basic System Diagram</b> .....	<b>6</b>
<b>2 Operating Conditions</b> .....	<b>7</b>
<b>2.1 Absolute Maximum Ratings</b> .....	<b>7</b>
<b>2.2 Recommended Operational Conditions</b> .....	<b>7</b>
<b>2.3 Input Pin Operation</b> .....	<b>7</b>
<b>2.4 Output Pin Operation</b> .....	<b>8</b>
<b>3 Chip Functionality</b> .....	<b>9</b>
<b>3.1 Primary Drive</b> .....	<b>9</b>
<b>3.2 Power Select Input</b> .....	<b>9</b>
<b>3.3 Power Control Input</b> .....	<b>9</b>
<b>3.4 Secondary Drive</b> .....	<b>10</b>
<b>3.5 Temperature Adjustment Output</b> .....	<b>10</b>
<b>3.6 Temperature Level Select Input</b> .....	<b>10</b>
<b>3.7 Power Normalisation Input</b> .....	<b>11</b>
<b>3.8 Transformer Select Logic Input</b> .....	<b>11</b>
<b>3.9 Transformer Select Logic Output</b> .....	<b>12</b>
<b>3.10 Reset</b> .....	<b>12</b>
<b>4 Chip Packaging</b> .....	<b>13</b>
<b>5 PCB Footprint</b> .....	<b>14</b>
<b>6 Revision Control</b> .....	<b>16</b>

# 1 Introduction

## 1.1 Overview

The Indice Light Emitting Diode (LED) Driver Chip offers a fast development path to deliver a product to market quickly for MR16 low voltage lighting. Unique to Indice is our direct halogen replacement compatibility technology which takes the headaches out of the product development by providing a fully functional reference design. The chip allows for the production of module that offers manufacturers a compact and flexible high power source, extremely efficient driver for low voltage LED lighting. The module is compatible with most dimmers and standard 12V AC electronic transformers and magnetic (iron core) transformers. These modules are suitable for driving high wattage LEDs for general and task lighting. Features include high speed, asynchronous control scheme, over-temperature shut down, and configurable output for matching LED voltage and power requirements.

## 1.2 Chip Benefits

The Indice LED Driver Chip is a leading edge silicon device that has the following benefits:

- **Small Package:** The control chip is supplied in a 16 pin QFN package to minimize consumed board space.
- **Low Voltage Supply:** The controller chip operates on a stable 3.3V supply.
- **Low Power:** The control chip implements power saving features which significantly reduce its power consumption during normal operation.
- **Temperature Select:** The temperature select pin allows engineers to customize the target temperature for normal operation. With safety shut down level selected according to the selected operating point.
- **Output Power Select:** The output power select pin allows engineers to customize the maximum desired output power before thermal management is engaged.
- **Power Normalisation:** Allows system power draw on varying supplies to be normalized to a more consistent value.
- **Asynchronous Drive:** The controller chip switches asynchronously, which helps to reduce Electro-Magnetic Interference (EMI) by spreading emissions over a large frequency band.

## 1.3 System Benefits

Indice LED Driver Chip is also available in customized control modules. The controller technology allows the direct replacement of halogen downlights removing the need to rewire the building. Licensees of the Indice controller technology will benefit from customized control modules with the following unique benefits:

- **Dimmable:** Our control chip provides dimming with most existing dimmers globally<sup>1</sup>.
- **Transformer compatibility:** Our control system is compatible with both electronic and magnetic transformers globally<sup>1</sup>.
- **High power factor:** 0.8 to 0.9 on most transformers meeting the US Energy Star requirements.
- **EMC Compliance:** Meets Class B requirements for CISPR 15/22, FCC Part 15 and EN55022.
- **Active temperature management:** Our controller continuously monitors the operating temperature of the lamp adjusting power accordingly which maximises LED life and brightness. In the event the ambient temperature reaches extremes, the controller will safely shut down the lamp. The lamp will turn back on when the ambient temperature drops below the set threshold.
- **Active Power Management:** Our control chip actively monitors the current through the LED ensuring that it runs within the manufacturer's specification.

---

<sup>1</sup> Refer to the Indice dimmer and transformer compatibility chart for complete details.

- **Extensive Testing:** Indice has carried out extensive testing of its control technology on dimmers and transformers from across the globe<sup>1</sup>.
- **Turn Key Designs** that are certified are ready for manufacture (*Note: Reference designs provided under license*).
- **Full PCB Support** on PCB design and iterative changes to support production improvements.
- **Full Component Support:** On alternative sourcing of components to reduce cost and lead times (This involves a detailed engineering process of thoroughly testing and validating parts).
- **Full Certification Support:** On certification for all major regions (Australia, US, Europe).
- **Full Access:** To design improvements and enhancements.

## 1.4 System Features

The customised control modules have the following features:

- Input voltage range: 12 V DC / 12 V AC.
- Input frequency range from DC to 300kHz AC.
- Output power scalable to 20W with the correct selection of switching silicon and magnetic parts.
- Adjustable LED output voltage from 3 to 29V<sup>2</sup>.
- Programmable over-temperature shut down, from 60 to 92 °C.
- Clock-less, asynchronous operation of primary switching reduces EMI test compliance issues.
- Compatible with 12V AC magnetic and electronic transformers.
- Compatible with 12V AC magnetic transformers with leading edge dimmer circuits<sup>1</sup>.
- Compatible with 12V AC electronic transformers with trailing edge dimmer circuits<sup>1</sup>.
- Small module size allows an easy integration into final products.
- Efficiency (Measured in default configuration from MR16 input pins to LED output).
  - Single stage: > 85%.
  - Dual stage: > 80% (Primary and secondary outputs used).

## 1.5 Suggested Applications

- Direct replacement for low voltage halogen downlights in commercial, residential and industrial lighting.
- Outdoor lighting controller for low voltage systems.
- Industrial LED controller for high reliability applications.
- Emergency lighting systems.
- Any other low voltage lighting system.

## 1.6 Indice Semiconductor Pty Ltd Support Contacts

The following key contacts should be used for any additional correspondence and queries in response to this document.

Email	<a href="mailto:support@indicesemi.com.au">support@indicesemi.com.au</a>
Phone	+61 3 9831 7400 (9am – 5pm, Mon – Fri, UTC+10:00)

<sup>1</sup> Refer to the Indice dimmer and transformer compatibility chart for complete details.

<sup>2</sup> Higher output voltages possible with increased voltage rating on certain parts.

## 1.7 Device Pin Out

Below in Figure 1 and Table 1 are details on the pin out and pin functions for the Indice LED Driver Chip.

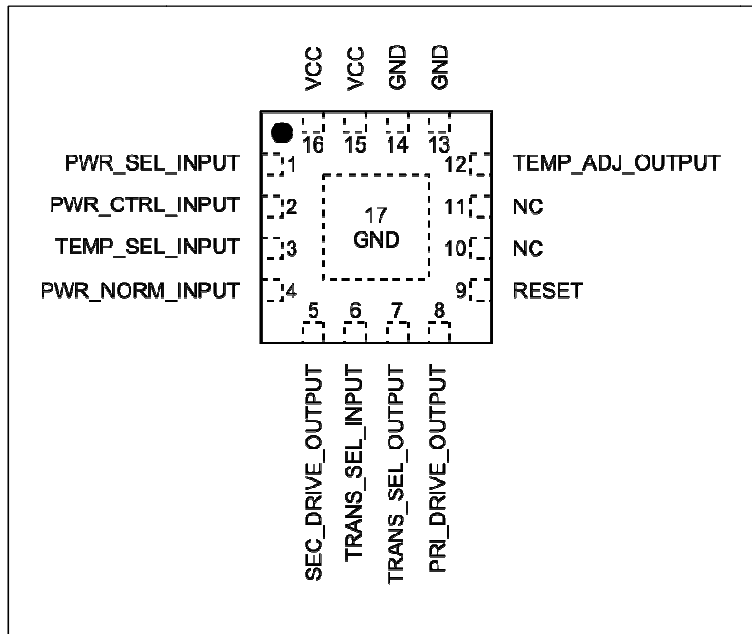

**Figure 1:** Top view of Indice LED Driver Chip QFN 16 package, with pins labelled. Dotted Lines indicate pins on bottom of chip.

Name	Pin Number	I/O	A/D	Description
PWR_SEL_INPUT	1	I	A	Control power select input pin.
PWR_CTRL_INPUT	2	I	A	Power control input pin.
TEMP_SEL_INPUT	3	I	A	Temperature level select pin.
PWR_NORM_INPUT	4	I	D	Power normalisation input pin.
SEC_DRIVE_OUTPUT	5	O	D	Secondary drive output pin.
TRANS_SEL_INPUT	6	I	D	Automatic transformer select input pin.
TRANS_SEL_OUTPUT	7	O	D	Automatic transformer select output pin.
PRI_DRIVE_OUTPUT	8	O	D	Primary drive output pin.
RESET	9	I	D	Reset input pin.
NC	10	-	-	Pin not connected. (Reserved for later expansion.)
NC	11	-	-	Pin not connected. (Reserved for later expansion.)
TEMP_ADJ_OUTPUT	12	O	D	Temperature adjustment output pin.
GND	13	-	-	Ground reference.
GND	14	-	-	Ground reference.
V <sub>CC</sub>	15	-	-	3.3 V supply voltage.
V <sub>CC</sub>	16	-	-	3.3 V supply voltage.
GND	17	-	-	Ground reference.

**Table 1:** Pin functions of Indice LED Driver Chip. I/O column indicates either I – Input or O – Output. A/D column indicates either A – Analogue or D – Digital.

## 1.8 Basic System Diagram

A system diagram depicting the INDICE0002 chip being used in a simplified LED driver is presented in Figure 2. This system shows a primary booster stage followed by a secondary buck stage, although the INDICE0002 chip can be used to drive other similar stages to achieve controlled LED driving.

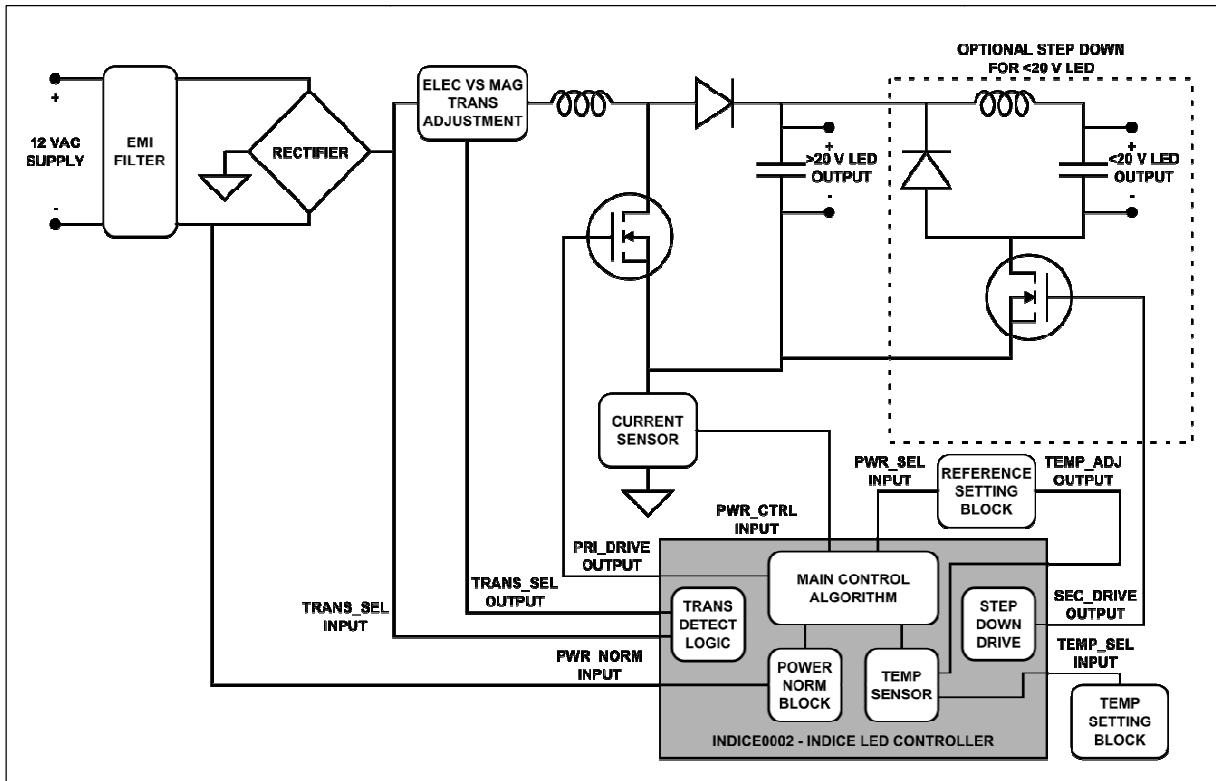

**Figure 2:** System diagram showing a simplified example of the INDICE0002 chip used within a low voltage LED driver.

## 2 Operating Conditions

### 2.1 Absolute Maximum Ratings

Subjecting the Indice LED Driver chip to any conditions beyond those listed in this section may cause permanent damage to the device. These are maximum condition ratings only. Exposure to the absolute maximum rated conditions for long periods can adversely affect device reliability. Proper operation of the device under any conditions, other than those indicated in the “Recommended Operational Conditions” section, is not implied. Absolute maximum ratings of the Indice LED Driver Chip are included in Table 2.

GND pin to $V_{CC}$ pin voltage.	-0.3 V to 4.1 V
Any other pin voltage. (Referenced to GND pin voltage.)	-0.3 V to $V_{CC} + 0.3$ V
Storage temperature range. $T_{STORAGE}$ <sup>(1)</sup> .	-55 °C to 150 °C

(1) Higher temperatures can be applied during board soldering according to current JEDEC J-STD-020 standards specification. Peak reflow temperatures should not exceed those classified on the device packaging.

**Table 2:** Absolute maximum ratings of the Indice LED Driver Chip.

### 2.2 Recommended Operational Conditions

Recommended operational conditions for the Indice LED Driver Chip are given in Table 3.

GND pin voltage.	0 V
$V_{CC}$ pin voltage. (Referenced to GND pin voltage.)	2.2 V to 3.6 V
Operating ambient free air temperature. $T_A$	-40 °C to 85 °C
Typical current draw	3mA

**Table 3:** Recommended operational conditions of the Indice LED Driver Chip.

### 2.3 Input Pin Operation

The measured operational characteristics of the Indice LED Driver Chip input pins are presented below, in Table 4. Leakage data on all high impedance input pins is given in Table 5. All of these values are measured over recommended supply voltages and operating ambient free air temperatures (unless otherwise stated.)

Parameter	Test Conditions	MIN	TYP	MAX	Unit
Rising edge input threshold voltage. $V_{IT+}$	$V_{CC} = 3$ V.	1.35		2.25	V
Falling edge input threshold voltage. $V_{IT-}$	$V_{CC} = 3$ V.	0.75		1.65	V
Input voltage hysteresis. $V_{HYS} = (V_{IT+} - V_{IT-})$	$V_{CC} = 3$ V.	0.3		1	V
Input capacitance. $C_{IN}$	GND or $V_{CC}$ applied to pin.		5		pF

**Table 4:** Input pin operation of the Indice LED Driver Chip.

Parameter	Test Conditions	MIN	TYP	MAX	Unit
Input leakage current. $I_{LEAK}$	$V_{CC} = 3$ V <sup>(1)</sup> .			±50	nA

(1) Leakage current measured with pin attached to GND or VCC. Each pin measured individually.

**Table 5:** High impedance input pin leakage operation of the Indice LED Driver Chip.

## 2.4 Output Pin Operation

The measured operational characteristics of the Indice LED Driver Chip output pins are presented below, in Table 6. These values are measured over recommended supply voltages and operating ambient free air temperatures (unless otherwise stated.)

Parameter	Test Conditions	MIN	TYP	MAX	Unit
High output voltage $V_{OH}$	$V_{CC} = 3\text{ V}$ , $I_{MAX} = 6\text{ mA}$ delivered.		$V_{CC} - 0.3$		V
Low output voltage $V_{OL}$	$V_{CC} = 3\text{ V}$ , $I_{MAX} = 6\text{ mA}$ drawn.		$GND + 0.3$		V

**Table 6:** Output pin operation of the Indice LED Driver Chip.

## 3 Chip Functionality

### 3.1 Primary Drive

The primary drive signal, PRI\_DRIVE\_OUTPUT, is used in conjunction with the power select and power control inputs, PWR\_SEL\_INPUT and PWR\_CTRL\_INPUT respectively, to provide closed loop control of the output power.

In terms of the basic control system, shown below in Figure 3, the PRI\_DRIVE\_OUTPUT signal can be considered as the control logic output into the system. The control logic itself is implemented within the Indice LED Driver Chip, along with some conditioning of the reference and sensor signals before comparison.

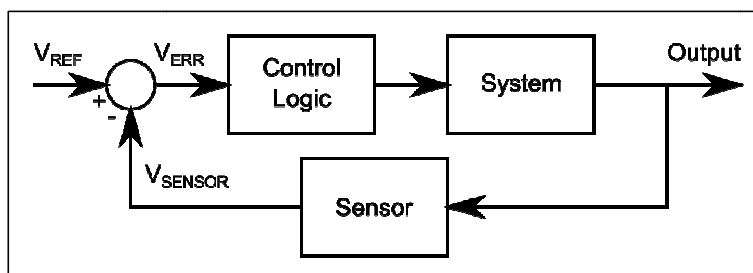

**Figure 3:** Basic closed loop control system. The figure shows the basic transfer blocks and the comparison of reference and sensor signals,  $V_{REF}$  and  $V_{SENSOR}$ , to produce the error signal,  $V_{ERR}$ .

The result of the conditioning, comparison and control logic is a digital drive line out of PRI\_DRIVE\_OUTPUT. This digital drive can be used to drive the primary switching element of an LED power converter circuit.

The controller assumes that this controller output is coupled to the output power through the system as shown in Figure 3, such that outputting a high level will increase the output power, while outputting a low level will decrease the output power. This relationship must hold in order to achieve closed loop control of the system.

### 3.2 Power Select Input

The power select input line, PWR\_SEL\_INPUT, is used to set the level that the control system is seeking to achieve on the power control input line, PWR\_CTRL\_INPUT. Control is then achieved by varying the primary drive signal, PRI\_DRIVE\_OUTPUT, in accordance with changes to both input signals.

With respect to the basic control system, shown previously in Figure 3, PWR\_SEL\_INPUT can be considered more generally as the reference signal used for the control comparison.

The signal undergoes some conditioning before comparison, so control system calculations should not be carried out based solely on raw signal comparisons.

### 3.3 Power Control Input

The power control input line, PWR\_CTRL\_INPUT, is used as an input point for output sensor information, closing the control loop and allowing for stable output power to the load LEDs.

PWR\_CTRL\_INPUT can be thought of as the sensor signal used in the basic control system shown above in Figure 3.

The signal undergoes some conditioning before comparison, so control system calculations should not be carried out based solely on raw signal comparisons.

### 3.4 Secondary Drive

The secondary drive signal, SEC\_DRIVE\_OUTPUT, is a 50% duty cycle drive signal at a fixed frequency. The secondary drive output frequency is generated by an internal oscillator and is always enabled. The signal timing has some inherent error and as such the typical values for this drive frequency and the error tolerance are shown in Table 7.

Parameter	Test Conditions	MIN	TYP	MAX	Unit
Sec drive frequency. $F_{SEC}$	$V_{CC} = 3\text{ V}$ .		1		MHz
Sec drive tolerance over temperature.	$V_{CC} = 3\text{ V}$ , $T_A = 0 - 85\text{ }^\circ\text{C}$ .	-3	$\pm 0.5$	+3	%
Sec drive tolerance over $V_{CC}$ .	$V_{CC} = 2.7 - 3.6\text{ V}$ , $T_A = 30\text{ }^\circ\text{C}$	-3	$\pm 2$	+3	%
Sec drive tolerance overall.	$V_{CC} = 2.7 - 3.6\text{ V}$ , $T_A = 0 - 85\text{ }^\circ\text{C}$ .	-6	$\pm 3$	+6	%

**Table 7:** Input pin operation of the Indice LED Driver Chip.

### 3.5 Temperature Adjustment Output

The temperature adjustment output, TEMP\_ADJ\_OUTPUT, is a varying duty cycle output, at approximately 3.9 kHz. The duty cycle of this waveform adjusts according to internal temperature control logic operating based on an internal temperature sensor. This signal can be used as an adjustment to the overall system power in order to maintain a constant control chip temperature. This is particularly useful if the control module and chip have tight thermal coupling to the output LEDs, because the signal then allows for the output power to be varied in order to keep the output LEDs at a suitable running temperature.

TEMP\_ADJ\_OUTPUT starts at 100% duty cycle. Given a high enough system power draw this will begin to raise the system temperature towards the selected temperature level.

The system then implements a 2<sup>nd</sup> order z-transform to target the desired temperature level. As the temperature of the system nears the selected temperature setting TEMP\_ADJ\_OUTPUT will begin to reduce the duty cycle to control the temperature. Continued raising temperature above the selected temperature setting will result in TEMP\_ADJ\_OUTPUT dropping to a 0% duty cycle.

If the temperature continues to rise then the controller will shut off all power into the system to prevent a critical system failure. This thermal shut off will occur when the internal chip temperature reaches 6.66 °C above the selected temperature level. The controller will remain in this state until the internal chip temperature again falls to the target level.

### 3.6 Temperature Level Select Input

The temperature level select input, TEMP\_SEL\_INPUT, is an analogue input used for setting the target temperature level for the temperature control system. The input takes an analogue signal from 0 V to 1.5V and quantises this into 16 V levels. These 16 levels then correspond to 1.66 °C steps levels from 62.0 °C to 86.9 °C, inclusive.

In order to set a particular temperature level it is best to input a voltage between the 0.1 V quantisation levels. The input signal will then be rounded down to the nearest quantisation level by the internal chip logic. Included in Table 8 below are the recommended voltage settings and their associated temperature set point.

Level	Recommended Voltage	Resulting Temperature
0	0.5 V	62 °C
1	0.15 V	63.66 °C
2	0.25 V	65.32 °C
3	0.35 V	66.98 °C
4	0.45 V	68.64 °C
5	0.55 V	70.30 °C
6	0.65 V	71.96 °C
7	0.75 V	73.62 °C
8	0.85 V	75.28 °C
9	0.95 V	76.94 °C
10	1.05 V	78.60 °C
11	1.15 V	80.26 °C
12	1.25 V	81.92 °C
13	1.35 V	83.58 °C
14	1.45 V	85.24 °C
15	1.5 V	86.90 °C

**Table 8:** Various target temperature settings. For each setting the recommended input voltage is given and the resulting target temperature.

### 3.7 Power Normalisation Input

The power normalisation input, PWR\_NORM\_INPUT, is used to interface with the Indice LED Driver Chip's power normalisation logic.

The power normalisation logic is designed to monitor a conditioned version of the rectified supply voltage and uses this information to normalise the maximum power of various supply transformers. Using this logic the power draw on magnetic transformers and electronic transformers with very small firing angles is normalised to a standardised amount.

The normalisation process is carried out by biasing the TEMP\_ADJ\_OUTPUT output. This biasing is undertaken at a slow rate of 2 Hz and can take up to 1 min to complete the adjustment process.

The power normalisation logic can be disabled by connecting the PWR\_NORM\_INPUT pin to GND with a 47 kΩ pull-down.

### 3.8 Transformer Select Logic Input

The transformer select logic input line, TRANS\_SEL\_INPUT, is used to interface with the Indice LED Driver Chip's transformer selection logic.

The transformer detection logic is designed to monitor a conditioned 12 V transformer supply voltage signal. The internal logic will use information in this signal to determine if the system is connected to a magnetic or electronic supply transformer. The transformer select logic output line, TRANS\_SEL\_OUTPUT, will then be changed to indicate the transformer type detected.

### 3.9 Transformer Select Logic Output

The transformer select logic output line, TRANS\_SEL\_OUTPUT, is the output from the transformer selection logic block. This block uses the signal connected to TRANS\_SEL\_INPUT to attempt to determine the type of the 12 V supply transformer. This allows the overall system to then adjust its operation to compensate for the transformer operation.

TRANS\_SEL\_OUTPUT starts at a default low level of  $V_{OL}$ , which indicates an electronic transformer. This is because typically electronic transformers have strict stall conditions, so it can be useful to change the system operation to ensure stable operation of electronic transformers immediately when connected to the supply. The transformer select logic then monitors TRANS\_SEL\_INPUT and determines, from this conditioned supply voltage signal, if it is indeed connected to an electronic transformer. If typical electronic transformer operation is not detected soon after start up, then the system will switch to indicating the connection of a magnetic transformer. This is indicated by an output high,  $V_{OH}$ , on the TRANS\_SEL\_OUTPUT.

Similarly the TRANS\_SEL\_OUTPUT will switch to indicating the presence of an electronic transformer if a typical electronic transformer signal is presented to TRANS\_SEL\_INPUT during operation.

There can be some error in the transformer selection logic, particularly if the input signal is of very low voltage level. This can happen when dimming to very low levels. A signal such as this will cause the logic to think it is connected to a magnetic transformer source.

### 3.10 Reset

The reset line, RESET, is an active low line that allows for the resetting of the Indice LED Driver Chip. This is useful for clearing and resetting the temperature level settings, as these settings are measured from the TEMP\_SEL\_INPUT and stored at system start-up.

It is advised that RESET be tied to VCC, by a 47 k $\Omega$  pull-up, during normal operation.

A voltage level of  $<V_{IT}$  on RESET will cause a reset event.

## 4 Chip Packaging

Below in Figure 4 are the dimensions of the QFN16 package used for the Indice LED Driver Chip.

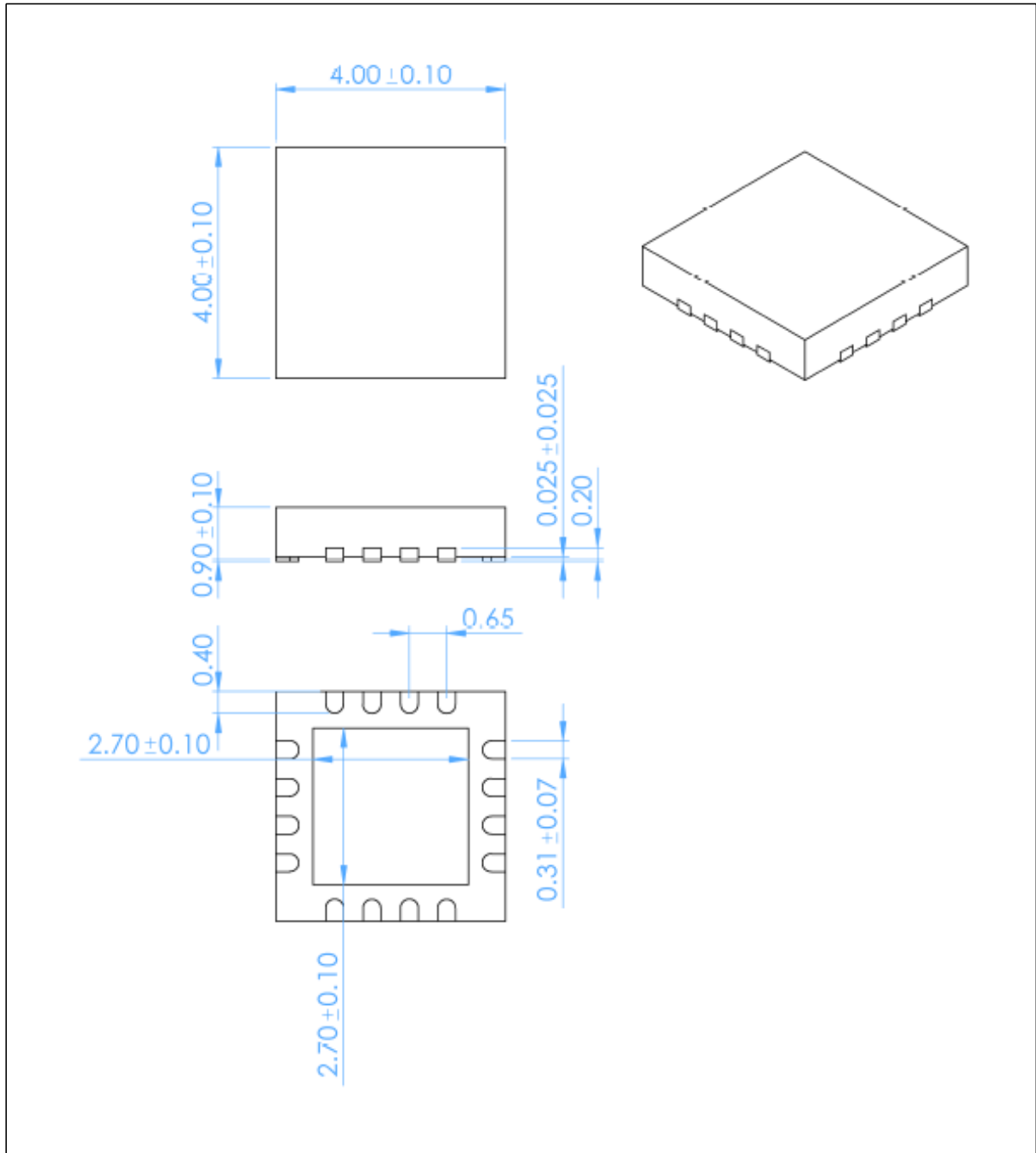

**Figure 4:** Package details. All noted dimensions in mm. Not to scale.

## 5 PCB Footprint

The suggested dimensions for PCB footprint and solder paste stencils are presented in Figure 5 and Figure 6 respectively.

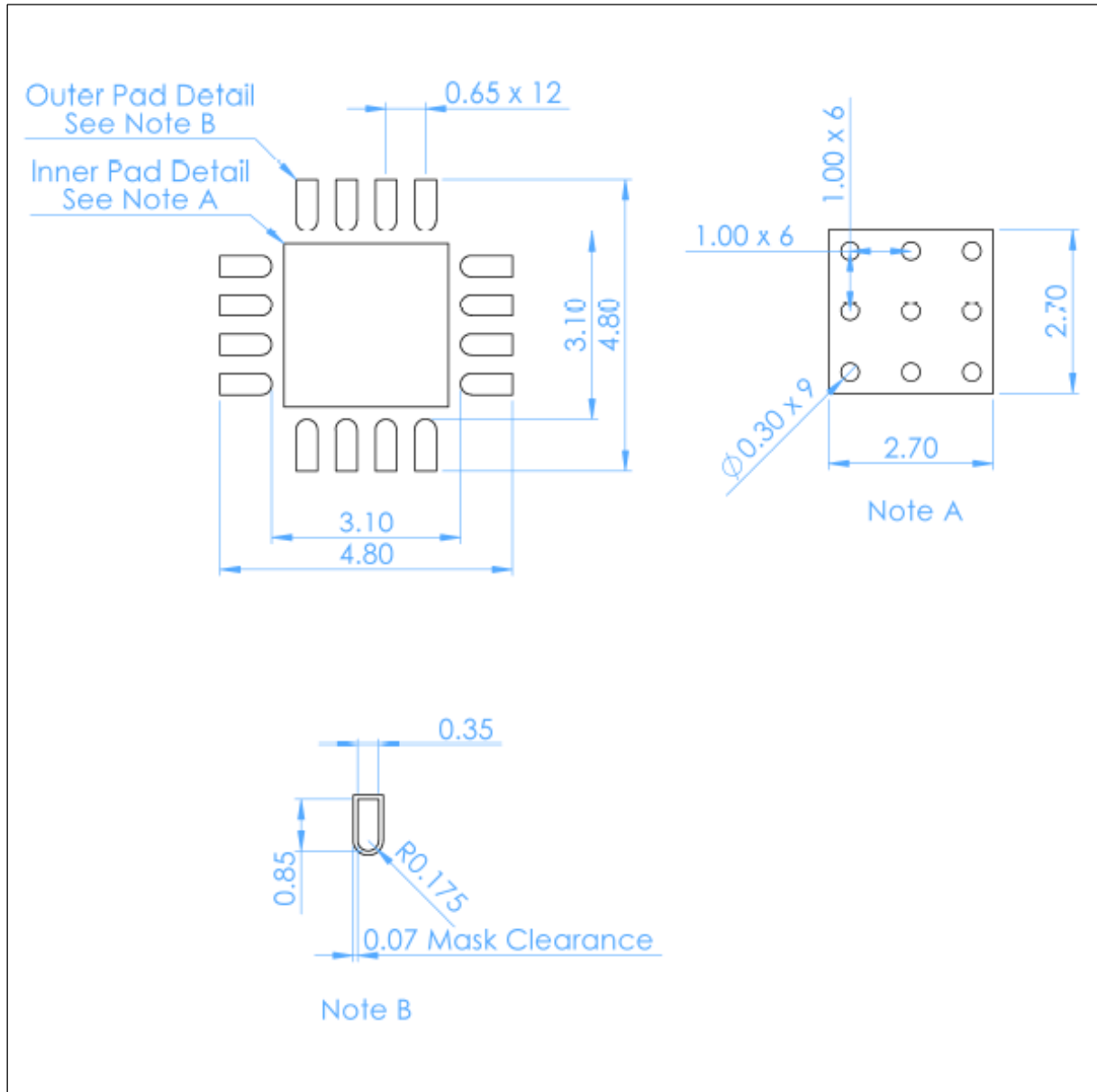

**Figure 5:** Suggested PCB footprint. All noted dimensions in mm. Not to scale.

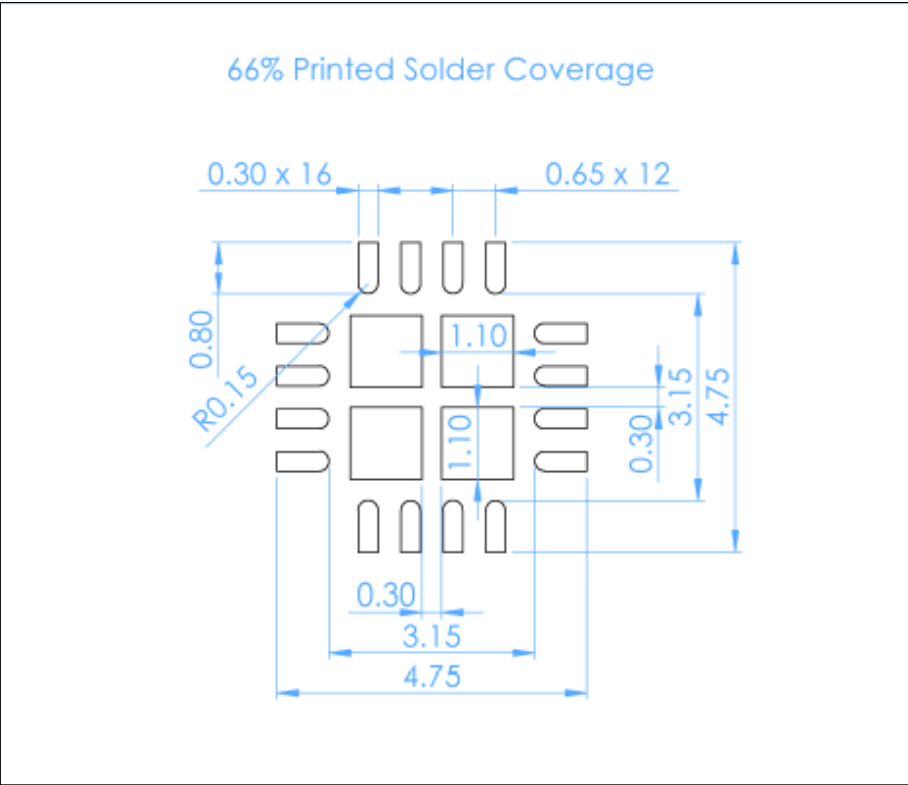

**Figure 6:** Suggested solder paste stencil. All noted dimensions in mm. Not to scale.

## 6 Revision Control

Version	Date	Details
0.1	07/12/2011	Document creation, from INDICE0001 datasheet.
0.2	15/02/2012	Moved revision control to bottom of document. Removed internal personal names from document. Revised contact information. Added system diagram.
0.3	01/03/2012	New front cover format.
0.4	01/07/2014	Modified of Indice logo and contact details