

UBA3070

LED backlight driver IC

Rev. 3 — 9 December 2010

Product data sheet

1. General description

The UBA3070 driver IC is the first member of a first generation of power-efficient LED backlight driver ICs. Highly efficient, flexible and reliable LED drivers can easily be designed using the UBA3070 control IC.

2. Features and benefits

- Switch-mode buck controller that drives strings of LEDs up to 600 V power-efficiently
- Controller with power-efficient Boundary Conduction Mode (BCM) operation:
 - ◆ Virtually no reverse recovery losses in freewheel diode
 - ◆ Zero Current Switching (ZCS) at switch, switch-on
 - ◆ Zero voltage or valley switching at switch, switch-on
 - ◆ Minimal required inductance value and size
- Suitable for direct Pulse Width Modulation (PWM) dimming
- Fast transient response through cycle-by-cycle current control, thereby:
 - ◆ Preventing over or undershoots in the Light Emitting Diode (LED) current
 - ◆ Enabling efficient PWM dimming by quickly turning the converter on and off and thus removing the need for extra dimming switches and high-side drivers
- Single controlled input voltage required for all UBA3070 driven LED strings in RGB or white backlighting units
- No binning on LED forward voltage required
- Protections:
 - ◆ UnderVoltage LockOut (UVLO)
 - ◆ Leading Edge Blanking (LEB)
 - ◆ OverCurrent Protection (OCP)
 - ◆ OverTemperature Protection (OTP)
- Low cost LED driver solution:
 - ◆ No fast-switching Schottky diode required due to ZCS
 - ◆ No dimming switch or high-side driver required for PWM dimming
 - ◆ Operates with smaller inductor than a comparable fixed-frequency Continuous Conduction Mode (CCM) controller

3. Applications

- The UBA3070 is suitable for high voltage LED lighting application:
 - ◆ LED backlighting in LCD televisions and monitors
 - ◆ General lighting applications
- The UBA3070 application is most efficient when driving long LED strings



4. Ordering information

Table 1. Ordering information

Type number	Package		Version
	Name	Description	
UBA3070T	SO8	plastic small outline package; 8 leads; body width 3.9 mm	SOT96-1

5. Block diagram

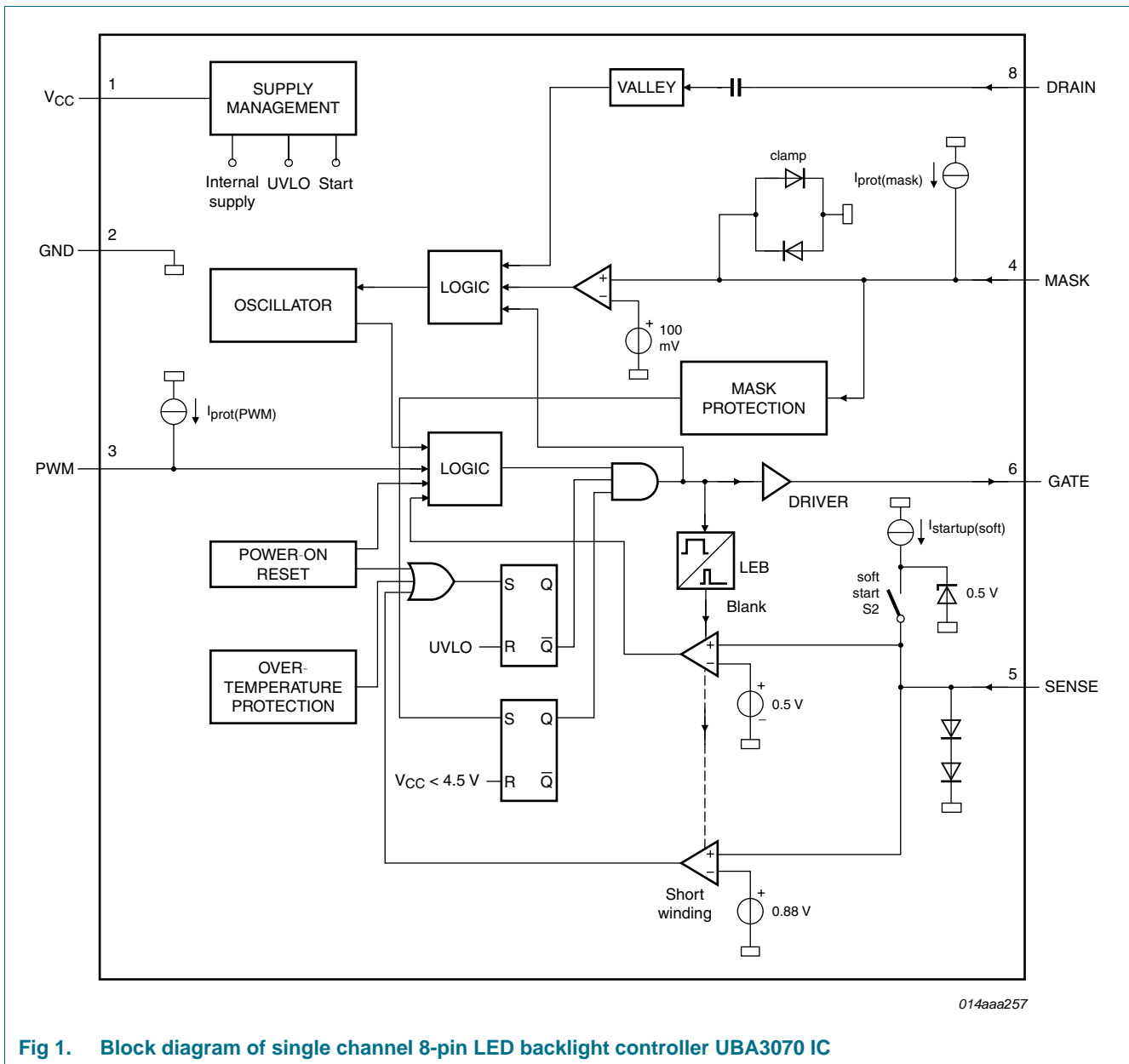

Fig 1. Block diagram of single channel 8-pin LED backlight controller UBA3070 IC

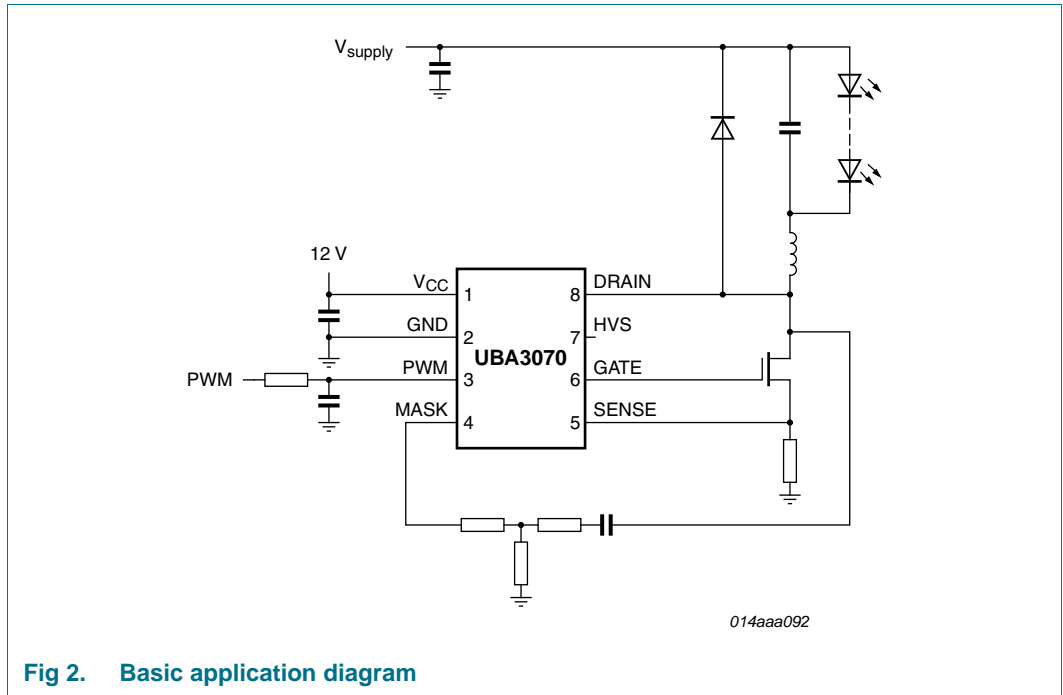

Fig 2. Basic application diagram

6. Pinning information

6.1 Pinning

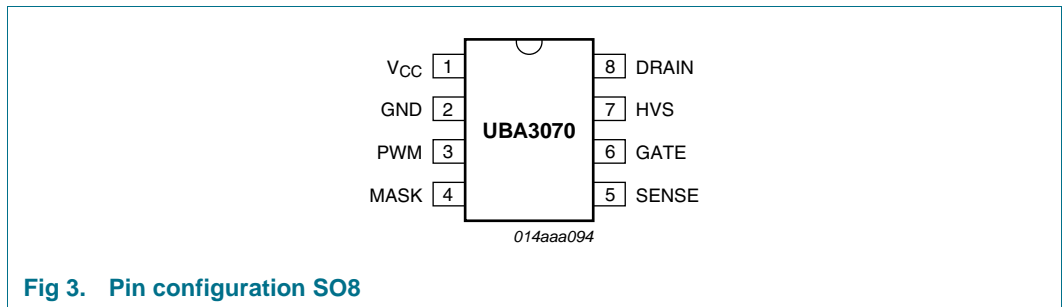

Fig 3. Pin configuration SO8

6.2 Pin description

Table 2. Pin description

Symbol	Pin S08	Description
V _{CC}	1	supply voltage
GND	2	ground
PWM	3	PWM input voltage
MASK	4	masking input voltage
SENSE	5	resistor programmable current sense input
GATE	6	gate driver output
HVS	7	high voltage safety spacer: not connected
DRAIN	8	drain of external MOSFET switch: input for valley sensing

7. Functional description

The UBA3070 is a monolithic driver IC for controlling the current through LED strings e.g. 45 green/blue/white LEDs connected in series making the UBA3070 IC especially suitable as an LED driver.

The driver stage enables optimal performance for series connected LED strings in 0D, 1D and 2D segmented Backlight Units (BLUs). Since the UBA3070 drives an external power device, it can be used for all kinds of BLU designs ranging from high-power to low-power LEDs, and high-voltage to low-voltage LED strings. Therefore, the UBA3070 is an excellent driver solution for all types of LEDs and LCD screen sizes. Combining the UBA3070 with suitable power devices means the quantity of drivers can be minimized by optimizing the quantity of series LEDs.

Each driver stage consists of a buck converter operating in BCM with its peak level determined by an external sense resistor. Since the peak and zero levels are fixed by design, the converter behaves as a current source. This gives an average LED current throughput that is half the peak value of that through the inductor. The ripple current through the LEDs can be selected by connecting an external capacitor in parallel with the LEDs.

7.1 Supply management and UVLO

As long as V_{CC} is below the $V_{CC(\text{startup})}$ level of typically 10 V, the supply current remains below 600 μA . The UBA3070 IC activates the converter as soon as the voltage on the V_{CC} pin passes the $V_{CC(\text{startup})}$ level. When the voltage on V_{CC} pin drops below the UVLO voltage typically 8.7 V the UBA3070 IC stops switching.

7.2 Current control and PWM

If the PWM input is HIGH ($> 2\text{ V}$) the converter is disabled and does not switch and, LED current remains at zero. When the PWM input pin is LOW ($< 0.5\text{ V}$) the converter is enabled and operates as follows.

The external Field-Effect Transistor (FET) is turned on and current in the inductor begins to build up. During the charging phase of the inductor the current is sensed across an external sense resistor. The internal driver turns off the external FET on detecting a voltage level of 0.52 V at the SENSE pin. The inductor now starts to freewheel its current through the external diode and starts discharging.

Following the discharge period the switch node rings. On detection of a valley or zero voltage on the switch node the internal driver turns on the external FET. As the FET is at zero current and minimal voltage, this results in minimal power losses and ElectroMagnetic Interference (EMI). The conversion cycle is repeated as described above, until the PWM input signal is driven high to disable the converter and steers the LED current to zero.

If the PWM pin is open circuit or not connected, a fault condition is assumed and the converter stops switching. Operation restarts as soon as the fault condition is removed.

7.3 Masking and valley switching

The MASK pin ensures that switch-on of the converter is at a valley during ringing and not at a peak during freewheeling of the inductor. If the voltage level at the MASK pin is above 100 mV, then switch-on of the switching FET is prevented. If the voltage level is below 100 mV, then switch-on prevention of the FET is released and at the moment of valley detection the FET is turned on. The signal for the MASK pin can be derived from the signal at the switch node as shown in [Figure 2](#). The current flowing into the MASK pin must be lower than the typical stop current of 60 μ A.

If the MASK pin is open circuit or not connected, a fault condition is assumed and the converter stops operating immediately. Operation restarts as soon as the fault condition is removed.

7.4 Conversion frequency

The maximum conversion frequency of the UBA3070 is limited to 175 kHz. However, due to production spread, the maximum conversion frequency of an individual UBA3070 sample can be as low as 145 kHz. Therefore, an inductance value must be selected so that the applications conversion frequency always remains below 145 kHz after taking into account variations due to the supply voltage, LED string voltage and component spread. There is no limitation for the minimum conversion frequency.

7.5 Minimum on-time

The LEB time, typically 370 ns is a fixed delay that determines the minimum on-time of the controller. The LEB time prevents the MOSFET switch from switching off unintentionally (due to coupling to the sense node) directly after the start of a conversion cycle.

7.6 OverCurrent Protection (OCP)

As the converter acts as a current source it is self-protected from overcurrent by an extra level of protection, i.e. a second trip level of typically 0.88 V applied to the short-winding/sense node as shown in [Figure 1](#). This second trip level is designed to protect the converter against short-circuits in external components e.g. in the diodes, inductors, capacitors and/or LEDs. If a short-circuit is detected the converter stops switching.

7.7 OverTemperature Protection (OTP)

OTP is provided in the UBA3070 IC and functions as follows. When the junction temperature exceeds the thermal shutdown temperature of typically 140 °C the converter stops switching.

7.8 Driver

The driver circuit to the gate of the power FET has a current sourcing capability of approximately 135 mA and a current sinking capability of 560 mA. This capability means the FET operates more efficiently with fast switch-on and switch-off cycles. A low driver source current has been chosen to limit the $\Delta V/\Delta t$ at switch-on thereby reducing EMI and voltage spikes across R_{sense} .

8. Limiting values

Table 3. Limiting values

In accordance with the Absolute Maximum Rating System (IEC 60134).^[1]

Symbol	Parameter	Conditions	Min	Max	Unit ^[1]	
Voltages						
V _{CC}	supply voltage	current limited	-0.4	+20	V	
V _{PWM}	voltage on pin PWM		-0.4	+5	V	
V _{MASK}	voltage on pin MASK	current limited	-0.4	-	V	
V _{SENSE}	voltage on pin SENSE	current limited	-0.4	-	V	
V _{DRAIN}	voltage on pin DRAIN		-0.4	+650	V	
Currents						
I _{PWM}	current on pin PWM		-	5	mA	
I _{MASK}	current on pin MASK		-250	+250	μA	
I _{SENSE}	current on pin SENSE		-1	+10	mA	
I _{GATE}	current on pin GATE	d < 10 %	-0.8	+2	A	
I _{DRAIN}	current on pin DRAIN		-	5	mA	
General						
P _{tot}	total power dissipation	T _{amb} < 70 °C	-	0.5	W	
T _{stg}	storage temperature		-55	+150	°C	
T _j	junction temperature		-40	+145	°C	
ESD						
V _{ESD}	electrostatic discharge voltage		-	-	-	
		all pins except pins DRAIN and V _{CC} ; HBM class 1	^[2]	-	2000	V
		pins DRAIN and V _{CC} ; HBM class 1	^[2]	-	1500	V
	any pin; MM	^[3]	-	200	V	

[1] All voltages are measured with respect to ground; positive currents flow into the UBA3070 IC. The V_{CC} pin may not be current driven. The voltage ratings are valid provided other ratings are not violated. The current ratings are valid provided the maximum power rating is not violated.

[2] Human Body Model (HBM): equivalent to discharging a 100 pF capacitor through a 1.5 kΩ resistor.

[3] Machine Model (MM): equivalent to discharging a 200 pF capacitor through a 0.75 μH coil and a 10 Ω resistor.

9. Thermal characteristics

Table 4. Thermal characteristics

Symbol	Parameter	Conditions	Typ	Unit
R _{th(j-a)}	thermal resistance from junction to ambient	in free air	150	K/W

10. Characteristics

Table 5. Characteristics

$T_{amb} = 25\text{ }^{\circ}\text{C}$; $V_{CC} = 15\text{ V}$; all voltages are measured with respect to ground; currents are positive when flowing into the UBA3070 IC; unless otherwise specified.

Symbol	Parameter	Conditions	Min	Typ	Max	Unit
V_{BR}	breakdown voltage		650	-	-	V
Supply voltage management (V_{CC} pin)						
$V_{CC(\text{startup})}$	start-up supply voltage		9.3	10	10.6	V
$V_{CC(\text{UVLO})}$	undervoltage lockout supply voltage		8.1	8.7	9.3	V
$V_{CC(\text{hys})}$	hysteresis of supply voltage	$V_{CC(\text{startup})} - V_{CC(\text{UVLO})}$	1.0	1.3	1.6	V
$I_{CC(\text{oper})}$	operating supply current	no load on GATE pin	1.1	1.3	1.5	mA
$I_{CC(\text{startup})}$	start-up supply current	$V_{CC} < V_{CC(\text{startup})}$	-	-	600	μA
$I_{CC(\text{prot})}$	protection supply current	$V_{CC} > V_{CC(\text{UVLO})}$	-	0.85	-	mA
Masking management (MASK pin)						
$V_{th(\text{MASK})}$	threshold voltage on pin MASK		50	100	150	mV
$V_{\text{clamp}(\text{neg})(\text{MASK})}$	negative clamp voltage on pin MASK	$I_{\text{MASK}} = -150\text{ }\mu\text{A}$	-0.5	-0.25	-0.05	V
$V_{\text{clamp}(\text{pos})(\text{MASK})}$	positive clamp voltage on pin MASK	$I_{\text{MASK}} = 250\text{ }\mu\text{A}$	0.5	0.7	0.9	V
$I_{\text{stop}(\text{pos})(\text{MASK})}$	positive stop current on pin MASK		54	60	66	μA
$t_{\text{sup}(\text{xfrm}_r\text{ring})}$	transformer ringing suppression time	start secondary stroke	1.1	1.5	1.9	μs
$I_{\text{prot}(\text{MASK})}$	protection current on pin MASK	$V_{\text{MASK}} = 50\text{ mV}$	-50 ^[1]	-	-10	nA
Oscillator						
$f_{\text{osc}(\text{high})}$	high oscillator frequency	V_{PWM} is LOW	145	175	205	kHz
PWM duty cycle control (PWM pin)						
$V_{IL(\text{en})\text{ILED}(\text{PWM})}$	LED current enable LOW-level input voltage on pin PWM		^[2] -	-	0.5	V
$V_{IH(\text{dis})\text{ILED}(\text{PWM})}$	LED current disable HIGH-level input voltage on pin PWM		^[2] 2.0	-	-	V
$I_{\text{prot}(\text{PWM})}$	protection current on pin PWM	$V_{\text{PWM}} = 1.5\text{ V}$	-1.0 ^[1]	-0.8	-0.5	μA
Valley switch (DRAIN pin)						
$(\Delta V/\Delta t)_{\text{vrec}}$	valley recognition voltage change with time		-85	-	+85	V/ μs
$t_{\text{d}(\text{vrec-swon})}$	valley recognition to switch-on delay time		-	150 ^[1]	-	ns
OCP (SENSE pin)						
$V_{\text{sense}(\text{max})}$	maximum sense voltage	$\Delta V/\Delta t = 0.1\text{ V}/\mu\text{s}$	0.48	0.52	0.56	V
t_{PD}	propagation delay	$\Delta V/\Delta t = 0.5\text{ V}/\mu\text{s}$	-	140	185	ns
V_{swp}	short-winding protection voltage		0.83	0.88	0.95	V
t_{leb}	leading edge blanking time		300	370	440	ns
$I_{\text{startup}(\text{soft})}$	soft startup current	$R_{\text{sense}} < 0.5\text{ V}$	45	60	75	μA

Table 5. Characteristics ...continued

$T_{amb} = 25\text{ }^{\circ}\text{C}$; $V_{CC} = 15\text{ V}$; all voltages are measured with respect to ground; currents are positive when flowing into the UBA3070 IC; unless otherwise specified.

Symbol	Parameter	Conditions	Min	Typ	Max	Unit
Driver (GATE pin)						
I_{source}	source current	$V_{CC} = 9.5\text{ V}$; $V_{GATE} = 2\text{ V}$	-	-135	-	mA
I_{sink}	sink current	$V_{CC} = 9.5\text{ V}$; $V_{GATE} = 2\text{ V}$	-	240	-	mA
		$V_{CC} = 9.5\text{ V}$; $V_{GATE} = 9.5\text{ V}$	-	560	-	mA
$V_{o(max)}$	maximum output voltage	$V_{CC} > 12\text{ V}$	-	11.5	12	V
OTP						
$T_{pl(max)}$	maximum protection level temperature		130	140	150	$^{\circ}\text{C}$
$T_{pl(hys)}$	protection level hysteresis temperature		-	8	-	$^{\circ}\text{C}$

[1] Guaranteed by design.

[2] When the voltage at the PWM pin is between 0.5 V to 2.0 V the peak current and the frequency is reduced.

11. Package outline

SO8: plastic small outline package; 8 leads; body width 3.9 mm

SOT96-1

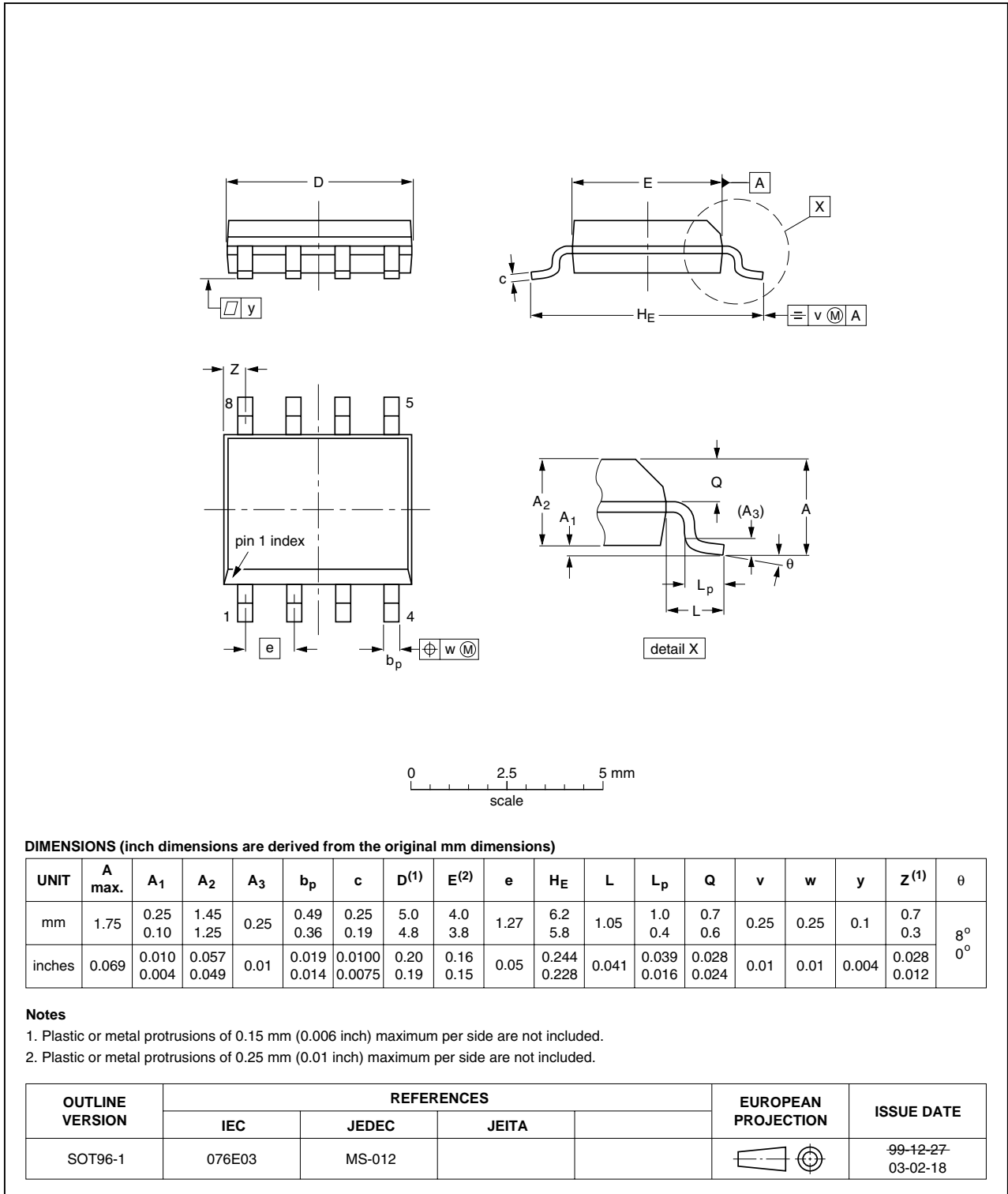

Fig 4. Package outline SOT96-1 (SO8)

12. Abbreviations

Table 6. Abbreviations

Acronym	Description
BCM	Boundary Conduction Mode
BLU	Backlight Unit
CCM	Continuous Conduction Mode
EMI	ElectroMagnetic Interference
FET	Field-Effect Transistor
HBM	Human Body Model
IC	Integrated Circuit
LCD	Liquid Crystal Display
LEB	Leading Edge Blanking
LED	Light Emitting Diode
MM	Machine Model
MOSFET	Metal-Oxide Semiconductor Field-Effect Transistor
OCP	OverCurrent Protection
OTP	OverTemperature Protection
PWM	Pulse Width Modulation
RGB	Red/Green/Blue
UVLO	UnderVoltage LockOut
ZCS	Zero Current Switching

13. References

- [1] **UM10400** — UBA3070 V1.2 demo board

14. Revision history

Table 7. Revision history

Document ID	Release date	Data sheet status	Change notice	Supersedes
UBA3070 v.3	20101209	Product data sheet	-	UBA3070 v.2
Modifications:	• Minor updates.			
UBA3070 v.2	20080212	Product data sheet	-	UBA3070 v.1
Modifications:	• The minimum value for junction temperature has been updated in Table 3 .			
UBA3070 v.1	20080605	Product data sheet	-	-

15. Legal information

15.1 Data sheet status

Document status ^{[1][2]}	Product status ^[3]	Definition
Objective [short] data sheet	Development	This document contains data from the objective specification for product development.
Preliminary [short] data sheet	Qualification	This document contains data from the preliminary specification.
Product [short] data sheet	Production	This document contains the product specification.

[1] Please consult the most recently issued document before initiating or completing a design.

[2] The term 'short data sheet' is explained in section "Definitions".

[3] The product status of device(s) described in this document may have changed since this document was published and may differ in case of multiple devices. The latest product status information is available on the Internet at URL <http://www.nxp.com>.

15.2 Definitions

Draft — The document is a draft version only. The content is still under internal review and subject to formal approval, which may result in modifications or additions. NXP Semiconductors does not give any representations or warranties as to the accuracy or completeness of information included herein and shall have no liability for the consequences of use of such information.

Short data sheet — A short data sheet is an extract from a full data sheet with the same product type number(s) and title. A short data sheet is intended for quick reference only and should not be relied upon to contain detailed and full information. For detailed and full information see the relevant full data sheet, which is available on request via the local NXP Semiconductors sales office. In case of any inconsistency or conflict with the short data sheet, the full data sheet shall prevail.

Product specification — The information and data provided in a Product data sheet shall define the specification of the product as agreed between NXP Semiconductors and its customer, unless NXP Semiconductors and customer have explicitly agreed otherwise in writing. In no event however, shall an agreement be valid in which the NXP Semiconductors product is deemed to offer functions and qualities beyond those described in the Product data sheet.

15.3 Disclaimers

Limited warranty and liability — Information in this document is believed to be accurate and reliable. However, NXP Semiconductors does not give any representations or warranties, expressed or implied, as to the accuracy or completeness of such information and shall have no liability for the consequences of use of such information.

In no event shall NXP Semiconductors be liable for any indirect, incidental, punitive, special or consequential damages (including - without limitation - lost profits, lost savings, business interruption, costs related to the removal or replacement of any products or rework charges) whether or not such damages are based on tort (including negligence), warranty, breach of contract or any other legal theory.

Notwithstanding any damages that customer might incur for any reason whatsoever, NXP Semiconductors' aggregate and cumulative liability towards customer for the products described herein shall be limited in accordance with the *Terms and conditions of commercial sale* of NXP Semiconductors.

Right to make changes — NXP Semiconductors reserves the right to make changes to information published in this document, including without limitation specifications and product descriptions, at any time and without notice. This document supersedes and replaces all information supplied prior to the publication hereof.

Suitability for use — NXP Semiconductors products are not designed, authorized or warranted to be suitable for use in life support, life-critical or safety-critical systems or equipment, nor in applications where failure or

malfunction of an NXP Semiconductors product can reasonably be expected to result in personal injury, death or severe property or environmental damage. NXP Semiconductors accepts no liability for inclusion and/or use of NXP Semiconductors products in such equipment or applications and therefore such inclusion and/or use is at the customer's own risk.

Applications — Applications that are described herein for any of these products are for illustrative purposes only. NXP Semiconductors makes no representation or warranty that such applications will be suitable for the specified use without further testing or modification.

Customers are responsible for the design and operation of their applications and products using NXP Semiconductors products, and NXP Semiconductors accepts no liability for any assistance with applications or customer product design. It is customer's sole responsibility to determine whether the NXP Semiconductors product is suitable and fit for the customer's applications and products planned, as well as for the planned application and use of customer's third party customer(s). Customers should provide appropriate design and operating safeguards to minimize the risks associated with their applications and products.

NXP Semiconductors does not accept any liability related to any default, damage, costs or problem which is based on any weakness or default in the customer's applications or products, or the application or use by customer's third party customer(s). Customer is responsible for doing all necessary testing for the customer's applications and products using NXP Semiconductors products in order to avoid a default of the applications and the products or of the application or use by customer's third party customer(s). NXP does not accept any liability in this respect.

Limiting values — Stress above one or more limiting values (as defined in the Absolute Maximum Ratings System of IEC 60134) will cause permanent damage to the device. Limiting values are stress ratings only and (proper) operation of the device at these or any other conditions above those given in the Recommended operating conditions section (if present) or the Characteristics sections of this document is not warranted. Constant or repeated exposure to limiting values will permanently and irreversibly affect the quality and reliability of the device.

Terms and conditions of commercial sale — NXP Semiconductors products are sold subject to the general terms and conditions of commercial sale, as published at <http://www.nxp.com/profile/terms>, unless otherwise agreed in a valid written individual agreement. In case an individual agreement is concluded only the terms and conditions of the respective agreement shall apply. NXP Semiconductors hereby expressly objects to applying the customer's general terms and conditions with regard to the purchase of NXP Semiconductors products by customer.

No offer to sell or license — Nothing in this document may be interpreted or construed as an offer to sell products that is open for acceptance or the grant, conveyance or implication of any license under any copyrights, patents or other industrial or intellectual property rights.

Export control — This document as well as the item(s) described herein may be subject to export control regulations. Export might require a prior authorization from national authorities.

Quick reference data — The Quick reference data is an extract of the product data given in the Limiting values and Characteristics sections of this document, and as such is not complete, exhaustive or legally binding.

Non-automotive qualified products — Unless this data sheet expressly states that this specific NXP Semiconductors product is automotive qualified, the product is not suitable for automotive use. It is neither qualified nor tested in accordance with automotive testing or application requirements. NXP Semiconductors accepts no liability for inclusion and/or use of non-automotive qualified products in automotive equipment or applications.

In the event that customer uses the product for design-in and use in automotive applications to automotive specifications and standards, customer (a) shall use the product without NXP Semiconductors' warranty of the

product for such automotive applications, use and specifications, and (b) whenever customer uses the product for automotive applications beyond NXP Semiconductors' specifications such use shall be solely at customer's own risk, and (c) customer fully indemnifies NXP Semiconductors for any liability, damages or failed product claims resulting from customer design and use of the product for automotive applications beyond NXP Semiconductors' standard warranty and NXP Semiconductors' product specifications.

15.4 Trademarks

Notice: All referenced brands, product names, service names and trademarks are the property of their respective owners.

16. Contact information

For more information, please visit: <http://www.nxp.com>

For sales office addresses, please send an email to: salesaddresses@nxp.com

17. Tables

Table 1.	Ordering information	2
Table 2.	Pin description	3
Table 3.	Limiting values	6
Table 4.	Thermal characteristics	6
Table 5.	Characteristics	7
Table 6.	Abbreviations	10
Table 7.	Revision history	11

continued >>

18. Figures

Fig 1.	Block diagram of single channel 8-pin LED backlight controller UBA3070 IC	2
Fig 2.	Basic application diagram	3
Fig 3.	Pin configuration SO8	3
Fig 4.	Package outline SOT96-1 (SO8)	9

continued >>

19. Contents

1	General description	1
2	Features and benefits	1
3	Applications	1
4	Ordering information	2
5	Block diagram	2
6	Pinning information	3
6.1	Pinning	3
6.2	Pin description	3
7	Functional description	4
7.1	Supply management and UVLO	4
7.2	Current control and PWM	4
7.3	Masking and valley switching	5
7.4	Conversion frequency	5
7.5	Minimum on-time	5
7.6	OverCurrent Protection (OCP)	5
7.7	OverTemperature Protection (OTP)	5
7.8	Driver	5
8	Limiting values	6
9	Thermal characteristics	6
10	Characteristics	7
11	Package outline	9
12	Abbreviations	10
13	References	10
14	Revision history	11
15	Legal information	12
15.1	Data sheet status	12
15.2	Definitions	12
15.3	Disclaimers	12
15.4	Trademarks	13
16	Contact information	13
17	Tables	14
18	Figures	15
19	Contents	16

Please be aware that important notices concerning this document and the product(s) described herein, have been included in section 'Legal information'.

© NXP B.V. 2010.

All rights reserved.

For more information, please visit: <http://www.nxp.com>

For sales office addresses, please send an email to: salesaddresses@nxp.com

Date of release: 9 December 2010

Document identifier: UBA3070