

embit

# EMB-Z2531PA-USB

Datasheet



**FCC ID: Z7H-EMBZ2531PAUSB**

The device complies with part 15 of the FCC Rules. Operation is subjected to the following 2 conditions: (1) this device may not cause harmful interference and (2) this device must accept any interference received, including interference that may cause undesired operation.



---

**FCC ID: Z7H-EMBZ2531PAUSB**

Brand: Embit

Model: EMB-Z2531PA-USB/xx; EMB-Z2531/xx; EMB-Z2531PA/xx; EMB-Z2531USB/xx; EMB-Z2531-USB/xx; EMB-Z2531PAUSB/xx; NETCE001/xx (just different commercial type names)  
/xx stands from EUT with integral antenna or EUT with antenna connector

Power supply: 4 to 6 VDC

Transmission frequency: 2405 - 2480 MHz

Other certifications: CE

The device complies with part 15 of the FCC Rules. Operation is subjected to the following 2 conditions: (1) this device may not cause harmful interference and (2) this device must accept any interference received, including interference that may cause undesired operation.

This equipment has been tested and found to comply with the limits for a Class B digital device, pursuant to Part 15 of the FCC Rules. These limits are designed to provide reasonable protection against harmful interference in a residential installation. This equipment generates, uses and can radiate radio frequency energy and, if not installed and used in accordance with the instructions, may cause harmful interference to radio communications. However, there is no guarantee that interference will not occur in a particular installation. If this equipment does cause harmful interference to radio or television reception, which can be determined by turning the equipment off and on, the user is encouraged to try to correct the interference by one or more of the following measures:

- Reorient or relocate the receiving antenna.
- Increase the separation between the equipment and receiver.
- Connect the equipment into an outlet on a circuit different from that to which the receiver is connected.
- Consult the dealer or an experienced radio/TV technician for help.



The device complies with the FCC's Rf exposure requirements for USB dongles.

Sar compliance for body-worn operation is based on a separation distance of 0.5 cm between the unit and the body of the user. End-user must be informed of the body-worn operating requirements for satisfying RF exposure compliance.

The highest report SAR value is: 0.99 W/kg

---

# Index

<b>1 Description</b>	<b>5</b>
1.1 Specifications	5
1.2 Applications	5
1.3 Block diagram	6
1.4 Microcontroller	6
1.5 Antenna	6
1.6 Power Amplifier / Low Noise Amplifier	9
1.7 Firmware	10
1.8 Developing tools	10
<b>2 Mechanical data</b>	<b>11</b>
2.1 Size	11
2.2 Antenna positioning	11
2.3 Notes	11
<b>3 On board devices</b>	<b>12</b>
<b>4 Electrical characteristics</b>	<b>12</b>
4.1 Absolute Maximum Ratings	12
4.2 Operating Conditions	12
4.3 Power Consumption	12
4.4 RF Characteristic	13
4.5 Limitations	13
<b>5 Compliance</b>	<b>14</b>
5.1 Introduction	14
5.2 Compliance: Important information	14
5.3 CE compliance	16
5.4 CE Output power	16
5.5 FCC Data	17
5.6 FCC Output power	18
5.7 FCC 802.15.4 channel 26	18
<b>6 Ordering informations</b>	<b>19</b>
6.1 Types	19
<b>7 Disclaimer</b>	<b>20</b>
7.1 Handling precautions	20
7.2 Limitations	20
7.3 Disclaimer of liability	20
7.4 Trademarks	20

# 1 Description

**EMB-Z2531PA-USB** is a USB dongle developed by **embit** for LR-WPAN applications. The solution is a modified version of the EMB-Z2530PA module that include a USB capable microcontroller, some on board hardware and connectors. The simplified design combines high performance to small dimensions and low cost, providing the system integrator a simple and easy way to add IEEE 802.15.4 / ZigBee low range wireless connectivity and multi-hop networking into existing products.

**EMB-Z2531PA-USB** is configured as an embedded micro system or simple data modem for low power applications in the 2.4 GHz ISM band. It is based on a Texas Instruments™ CC2531 single chip device which is an 8051 8 bit controller with 256 kbyte Flash memory and 8 kbyte of RAM. The device includes a USB transceiver, a hardware accelerator for the MAC IEEE802.15.4 and a 2.4 GHz transceiver.

The ad-hoc RF section includes a power amplifier and a low noise amplifier which guarantee best-in-class performance in terms of covered area and power consumption. The output power can be increased up to +20 dBm by simple software configurations and the sensitivity is configurable between two options, allowing to cover distances up to 500 meters (LoS); the U.FL receptacle allows the connection of an external antenna.

**EMB-Z2531PA-USB** include two LEDs and a switch on board, the USB connector and a programmer connector. The power supply conditioning chain is integrated on the dongle.

## 1.1 Specifications

- 8 bit 8051 MCU
- 256K Flash, 8K RAM
- Output power: up to +20 dBm (100 mW)
- Sensitivity: up to -105 dBm (high sensitivity mode)
- PCB antenna (PIFA), wire connector and uFL receptacle for external antennas
- Coverage: up to 500 meters (LoS)
- Unique IEEE address (64 bit) on-board
- USB 2.0 certified full speed transceiver (12 Mbps)
- USB type A connectors
- Embit programming interface
- 2 LEDs and 1 switch

## 1.2 Applications

- **Metering:** thermostat, meters, remote devices, displays, etc..
- **Home/Buildings Automation:** safety systems and access control, HVAC, door/window control, lightning, etc..
- **Industrial Automation:** process control, wireless sensor networks, identification and asset tracking, etc..
- **Healthcare:** blood pressure monitoring, thermometers, ECG, etc..

## 1.3 Block diagram

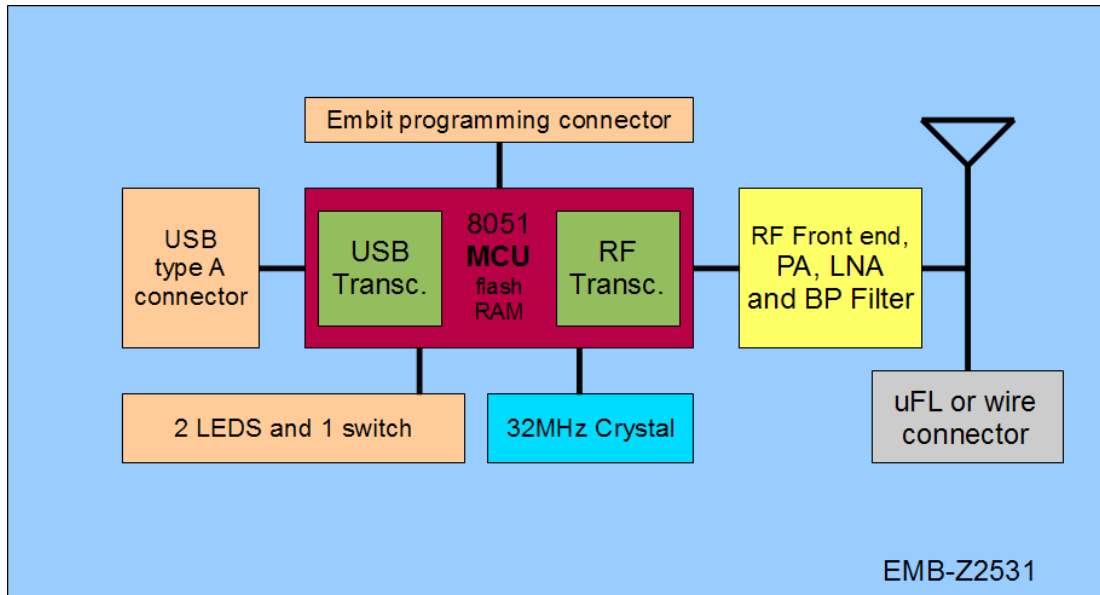

Image 1: block diagram for the EMB-Z2531PA-USB

## 1.4 Microcontroller

CC2531 is an integrated Texas Instruments™ platform for IEEE 802.15.4/ZigBee. The device integrates a low power 2.4 GHz transceiver, a CPU based on an 8051 core (8 bit) with hardware accelerator for the IEEE 802.15.4 MAC and a USB transceiver.

The CC2531 can be used for different wireless applications, starting from the simple point to point proprietary protocol to ZigBee mesh networks, and has been developed to offer high computational power with low consumption.

The 8051 8 bit core works at 32 MHz; there are 256 kbyte of flash memory and 8 kbyte of RAM memory.

## 1.5 Antenna

The EMB-Z2531PA-USB offers three different antenna options:

- PIFA antenna directly printed on the PCB with an omnidirectional emission diagram (xz plane). The performances of this antenna are influenced by the positioning of the USB dongle in the system (see paragraph “Antenna positioning”). The antenna specifications are provided in next paragraph (images might refer to the EMB-Z2530PA module that shares with the EMB-Z2531PA-USB all the RF section).

- Wire antenna: hole for soldering a wire antenna.
- External antenna connector (optional): 50 Ohm single ended U.FL connector.

### 1.5.1 PIFA antenna radiation diagrams

The printed antenna of the **EMB-Z2531PA-USB** is a simple and performant solution for a 2,4 GHz system. It has a maximum gain of +1,5 dBi, positioned in the xy plane (see 3D radiation diagram).

Here is the 3D radiation pattern:

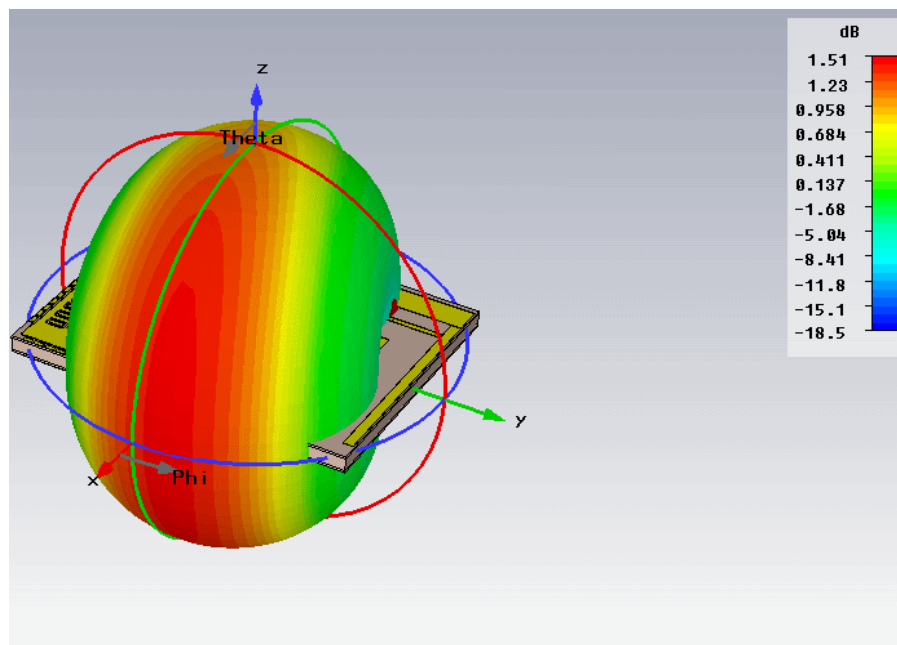

Image 2: 3D radiation pattern

Polar radiation pattern:

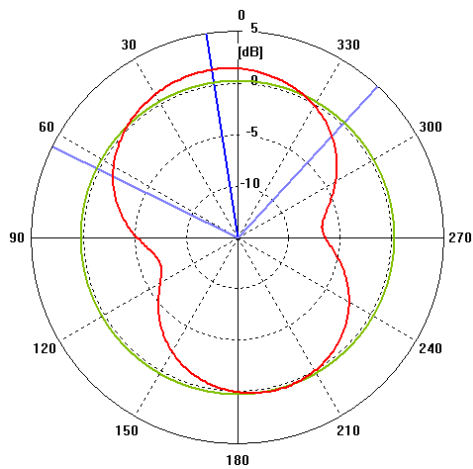

Image 3: polar radiation pattern, xy plane

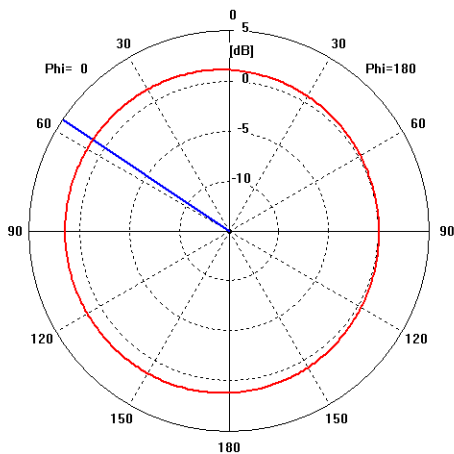

Image 4: polar radiation pattern, yz plane

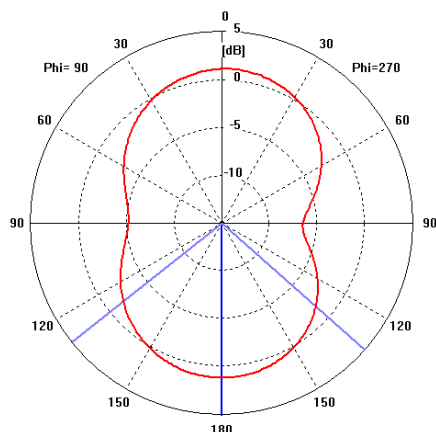
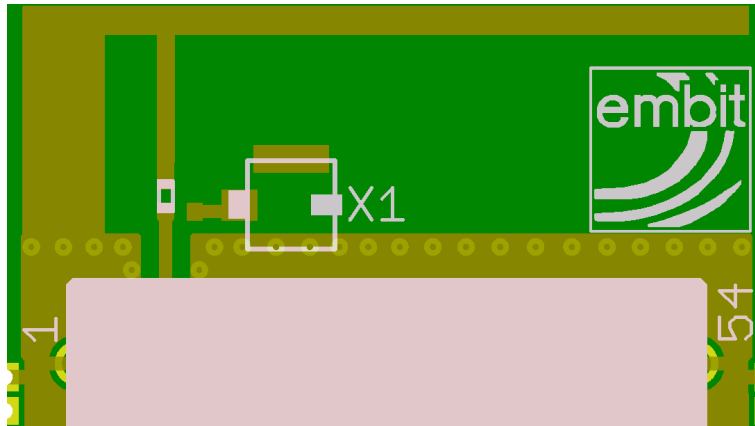

Image 5: polar radiation pattern, xz plane

### 1.5.2 Antenna selection (PIFA/external)

To select the antenna option the last 0402 resistor (zero R) or capacitor (10 pF) in the RF chain (the one closer to the printed antenna) must be rotated from vertical to horizontal position and viceversa. If the PIFA antenna is desired, the component must be installed in vertical position, as shown in the following picture:



*Image 6: C3 capacitor installation for PIFA antenna*

If an external antenna is to be used, either through U.FL connector or wire soldering point, the C3 capacitor must be installed in horizontal position, as shown in the following picture:

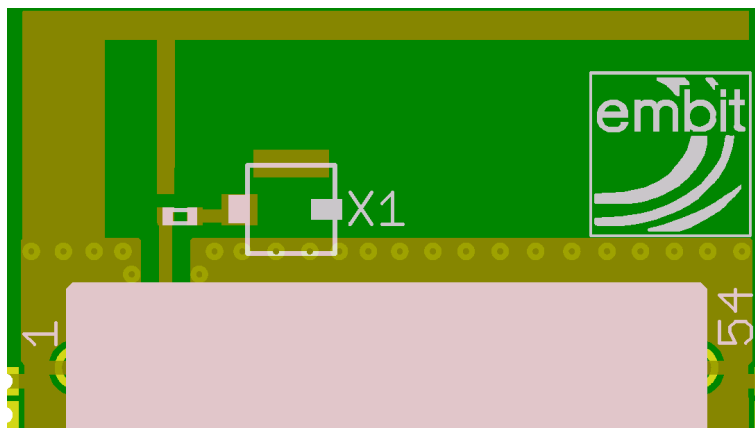

*Image 7: C3 capacitor installation for external antenna*

## 1.6 Power Amplifier / Low Noise Amplifier

The EMB-Z2531PA-USB is equipped with a PA / LNA combination to increase the communication range of the device. The PA provides a fixed gain of +20 dBm and the LNA can provide a gain of +11 dBm or +1 dBm selectable from the MCU. To switch between low gain and high gain the MCU must drive the pin 0 of port R low (high gain) or high (low gain).

## 1.7 Firmware

The EMB-Z2531PA-USB is compatible with the TIMAC stack and Z-Stack provided by Texas Instruments. Some modifications must be done to drive the external PA and LNA and the USB pull-up. For an insight guide, please consult the appropriate documents.

### 1.7.1 Power Amplifier interface

The EMB-Z2531PA-USB has an integrated power amplifier and low noise amplifier that must be controlled by the transceiver. Depending on the stack some modifications might be required in order to control the front-end. The interface between transceiver and front-end is composed of an SPI port and three GPIO pins: Enable, PA\_enable and Low/High\_Sensitivity.

The Enable pin (for controlling the LNA) is remapped from P1.4 to P1.0 when comparing to Texas Instruments Evaluation Modules and so the right settings for OBSSEL0:

```
OBSSEL0 = RFC_OBS_CTRL1;  
// OBSSEL4 = RFC_OBS_CTRL1;
```

### 1.7.2 Switches and LEDs

The EMB-Z2531PA-USB have 2 leds and a switch mapped as the EMB-Z2530PA module. Some remapping of the LED and switch pins is therefore required if starting from the Texas Instruments stacks. For further information please consult the appropriate documents.

The pinout is as follows:

- LED1 - Connected to VDD
- LED2 - Connected to P2.0 (lit when P2.0 is set high)
- SW1 - Connected P0.6 (ground signal when pressed)

### 1.7.3 USB pull-up

The EMB-Z2531PA-USB have the USB pullup remapped from P1.0 to P1.3.

## 1.8 Developing tools

For programming the EMB-Z2531PA-USB any emulator provided by Texas Instruments™ might be used (CC Debugger, SmartRF, etc.). The IAR IDE is suggested for working with the stacks.

## 2 Mechanical data

### 2.1 Size

The mechanical dimensions of the **EMB-Z2531PA-USB** are 60,40 x 22,60 mm. The thickness is 7,0 mm, CAN Shield, USB connector and programming interface included.

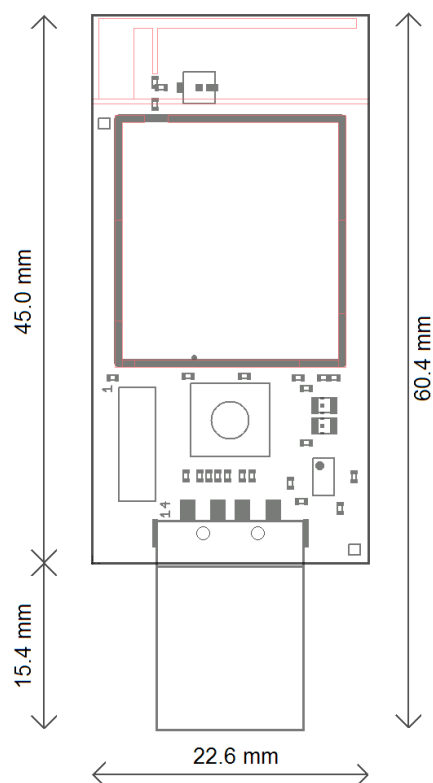

*Image 8: Outline*

### 2.2 Antenna positioning

Some care must be taken when positioning the antenna inside a host system. If using the integrated PIFA antenna, the side of the PCB on which the antenna is located must be positioned away from metal parts of the case or other PCBs.

### 2.3 Notes

- Keep antenna clear of metal parts of the casing or system.
- Don't use metal enclosures to avoid RF signal degradation.

**Note:** Taking no account this recommendations may affect the radio performances.

## 3 On board devices

Two LEDs are located on the USB dongle. One is connected to VDD and the second one can be controlled by the microcontroller using the P2.0 pin.

One switch is also mounted on the pin P0.6.

The embit programming interface can be used to program the microcontroller. Please read the appropriate document for more details.

## 4 Electrical characteristics

### 4.1 Absolute Maximum Ratings

	Value	Unit
Power Supply Voltage	6	Vdc
Voltage on any pin (beside USB pins)	3,6	Vdc
RF input power ( $P_{MAX}$ )	10	dBm
Storage Temp. Range	-45 ~ +125	°C

### 4.2 Operating Conditions

Parameter	Min	Typ	Max	Unit
Power Supply Voltage (Vcc)	4		6	Vdc
Input Frequency	2405		2480	MHz
Operating Temperature Range	-40		85	°C

### 4.3 Power Consumption

Mode	Typ. value	Unit
Transmit	135*	mA
Receive	28*	mA
Sleep	Up to 1.1**	µA

- The consumption doesn't count the power needed for the LEDs

\*\* 1.1 µA can be obtained in power mode 2 with sleep timer running (LEDs are excluded).

## 4.4 RF Characteristic

Parameter	Min	Typ	Max	Unit
RF Frequency Range	2400		2483,5	MHz
RF Data Rate		250		Kbps
Nominal Output Power	--	+10	--	dBm
Programmable Output Power Range	-5	--	+20	dBm
Receiver Sensitivity (1% PER) - Normal mode	--	-94	--	dBm
Receiver Sensitivity (1% PER) - High sensitivity mode	--	-105	--	dBm
Saturation (IP3) - Maximum Input Level	-2			dBm

## 4.5 Limitations

Every operation involving a modification on the internal components of the device will void the warranty.

## 5 Compliance

### 5.1 Introduction

The purpose of this chapter is to describe which behaviour the user **MUST** have in order to operate the device under compliance with current regulations. The details described here are then to be read carefully and applied literally. Also, please read carefully all the other documentation available in order to understand all the limits and ensure compliance of the final application.

The **EMB-Z2531PA-USB** is certified for CE and FCC compliance. The different regulations have different limitations and impose different approaches to the device that will be discussed in different chapters. Any aspect that both the regulations have in common will be described in an appropriate chapter in order to keep readability of this document at maximum.

The main aspect that the user **MUST** consider is the output power. The device itself is compliant and ready to be used but care must be taken in setting an appropriate output power when programming the devices. The device can output up to 20 dBm of conducted power which translates into up to 21.5 dBm of eirp with the integrated antenna or more if using an external antenna. Please follow the directives in this document to set the appropriate output power for the antenna you are using. Any other antenna that is not covered in the certification must not be used unless a new certification is performed.

### 5.2 Compliance: Important information

The device is to be used in accordance with the current guide.

The antennas used must be one of those indicated by the manufacturer and the output power must be set as required by the present document.

There is no duty cycle limit for this device if the appropriate power settings are respected.

Any modification on the device will void the certification.

The device can only be used with the antennas specified in the following table and the power setting must not exceed those indicated in this table for each antenna and operative area (CE or FCC). For correctly operate the devices with the stack provided please set the output power according to the following table. The “Maximum tx power” column refers to the power to be set in the stack and might differ slightly from the effective output power (see power tables). If the device is using the integrated antenna, please consider the settings specified for the EMB-AN24-15PFA antenna.

Antenna code	Antenna type	Antenna gain	Maximum tx power (for CE)	EIRP (for CE)	Maximum tx power (for FCC)	EIRP (for FCC)
EMB-AN24-14YA	Yagi	+14,0 dBi	+1 dBm	15,0 dBm	+20 dBm	34,0 dBm
EMB-AN24-12YA	Yagi	+12,0 dBi	+2 dBm	14,0 dBm	+20 dBm	32,0 dBm
EMB-AN24-20HWDU	1/2 wave dipole captive mount	+2 dBi	+12 dBm	+14,0 dbm	+20 dBm	+22,0 dbm
EMB-AN24-00QWS	1/4 wave stubby	+0 dBi	+14 dBm	+14,0 dbm	+20 dBm	+20,0 dbm
EMB-AN24-21DBA	Dual band antenna	+2,1 dBi	+12 dBm	+14,1 dbm	+20 dBm	+22,1 dbm
EMB-AN24-50FPCBA	Flexible PCB antenna	+5 dBi	+9 dBm	+14,0 dbm	+20 dBm	+25,0 dbm
EMB-AN24-25FPCBABD	Flexible PCB antenna	+2,5 dBi	+12 dBm	+14,5 dbm	+20 dBm	+22,5 dbm
EMB-AN24-25FPCBA	Flexible PCB antenna	+2,5 dBi	+12 dBm	+14,5 dbm	+20 dBm	+22,5 dbm
EMB-AN24-15FPCBA	Flexible PCB antenna	+1,5 dBi	+13 dBm	+14,5 dbm	+20 dBm	+21,5 dbm
EMB-AN24-22MA	Mini antenna	+2,2 dBi	+12 dBm	+14,2 dbm	+20 dBm	+22,2 dbm
EMB-AN24-15MA	Mini antenna	+1,5 dBi	+13 dBm	+14,5 dbm	+20 dBm	+21,5 dbm
EMB-AN24-40SMA	Multi frequency antenna	+4 dBi	+11 dBm	+15,0 dbm	+20 dBm	+24,0 dbm
EMB-AN24-20SMA	Multi frequency antenna	+2 dBi	+11 dBm	+15,0 dbm	+20 dBm	+22,0 dbm
EMB-AN24-70pA	Portable swivel antennas panel	+7 dBi	+7 dBm	+14,0 dbm	+20 dBm	+27,0 dbm
EMB-AN24-50pA	Portable swivel antennas panel	+5 dBi	+9 dBm	+14,0 dbm	+20 dBm	+25,0 dbm
EMB-AN24-50SA	Portable swivel antennas panel	+5 dBi	+9 dBm	+14,0 dbm	+20 dBm	+25,0 dbm
EMB-AN24-40pA	Portable swivel antennas panel	+4 dBi	+11 dBm	+15,0 dbm	+20 dBm	+24,0 dbm
EMB-AN24-15PFA	Printed PCB antenna - pifa	+1,5 dBi	+11 dBm	+12,5 dbm	+20 dBm	+21,5 dbm
EMB-AN24-55RDD	Rubber duck - dipole antenna	+5,5 dBi	+9 dBm	+14,5 dbm	+20 dBm	+25,5 dbm
EMB-AN24-50RDD	Rubber duck - dipole antenna	+5 dBi	+9 dBm	+14,0 dbm	+20 dBm	+25,0 dbm
EMB-AN24-22WMA	Wall mount antenna	+2,2 dBi	+12 dBm	+14,2 dbm	+20 dBm	+22,2 dbm

Antenna code	Antenna type	Antenna gain	Maximum tx power (for CE)	EIRP (for CE)	Maximum tx power (for FCC)	EIRP (for FCC)
EMB-AN24-10PA	Patch antenna	+10 dBi	+5 dBm	+15,0 dBm	+20 dBm	+30,0 dBm
EMB-AN24-12CA	Corner antenna	+12 dBi	+2 dBm	+14,0 dBm	+20 dBm	+32,0 dBm

## 5.3 CE compliance

The EMB-Z2531PA-USB is in compliance with the essential requirements and other relevant provisions of Directive 1999/5/EC.



The Declaration of Conformity made under Directive 1999/5/EC is available for viewing at the following location in the EU community:

Embit s.r.l.  
 via Emilia Est, 911  
 41122 Modena (MO)  
 Italy

**WARNING:** The exclamation mark indicates that this device is classified as “Class 2” radio equipment. The radio equipment is reprogrammable. It is not guaranteed that all limits and regulation compliance are satisfied once the device is reprogrammed. The user must take the full responsibility of operating the module properly satisfying regulation constrains that applies. The antenna is permanently attached to the card, removing the included antenna or modifying the board or antenna connector invalidates the certification.

## 5.4 CE Output power

The CE regulation allows for up to 20 dBm of EIRP output power but imposes a maximum power spectral density of +10 mW/MHz. Considering the bandwidth of the 802.15.4 and ZigBee, this translates into a reduction of the maximum usable output power. Also spurious emission regulations might impose a lower output power. Consider the antennas table from previous chapter for setting the right output power.

## 5.5 FCC Data

FCC ID: Z7H-EMBZ2531PAUSB

Brand: Embit

Model: EMB-Z2531PA-USB/xx; EMB-Z2531/xx; EMB-Z2531PA/xx; EMB-Z2531USB/xx; EMB-Z2531-USB/xx; EMB-Z2531PAUSB/xx; NETCE001/xx (just different commercial type names) /xx stands from EUT with integral antenna or EUT with antenna connector

Power supply: 4 to 6 VDC

Transmission frequency: 2405 - 2480 MHz

Other certifications: CE

The device complies with part 15 of the FCC Rules. Operation is subjected to the following 2 conditions: (1) this device may not cause harmful interference and (2) this device must accept any interference received, including interference that may cause undesired operation.

This equipment has been tested and found to comply with the limits for a Class B digital device, pursuant to Part 15 of the FCC Rules. These limits are designed to provide reasonable protection against harmful interference in a residential installation. This equipment generates, uses and can radiate radio frequency energy and, if not installed and used in accordance with the instructions, may cause harmful interference to radio communications. However, there is no guarantee that interference will not occur in a particular installation. If this equipment does cause harmful interference to radio or television reception, which can be determined by turning the equipment off and on, the user is encouraged to try to correct the interference by one or more of the following measures:

- Reorient or relocate the receiving antenna.
- Increase the separation between the equipment and receiver.
- Connect the equipment into an outlet on a circuit different from that to which the receiver is connected.
- Consult the dealer or an experienced radio/TV technician for help.

This equipment is approved only for mobile and base station transmitting devices, separation distances of (i) 20 centimeters or more for antennas with gains < 6 dBi or (ii) 2 meters or more for antennas with gains  $\geq$  6 dBi should be maintained between the antenna of this device and nearby persons during operation. To ensure compliance, operation at distances closer than this is not recommended.

## 5.6 FCC Output power

The FCC regulation allows for up to 30 dB or output power plus up to 6 dBi of assembly gain which translates into up to +36 dBm of EIRP. The **EMB-Z2531PA-USB** can output up to +20 dBm and so, when using the allowed antennas, will have no problems with the output power limit. Spurious emission and spectral density doesn't limit the output power neither on the **EMB-Z2531PA-USB** and so every output power setting can be used.

## 5.7 FCC 802.15.4 channel 26

When using the channel 26 of the 802.15.4 frequency band special care must be taken. The FCC regulations impose a spectral power mask with a falling edge too close in frequency to the channel 26. To keep compliance with FCC regulation, avoid using channel 26, lower the output power by 10 dBm or use a duty cycle lower than 33 %.

## 6 Ordering informations

### 6.1 Types

Part No.	Description
EMB-Z2531PA-USB/IA	EMB-Z2530PA-USB integrated PIFA antenna
EMB-Z2531PA-USB/UL	EMB-Z2530PA-USB U.FL connector for external antenna

Related products:

Part No.	Description
EMB-Z2530PA-EVK	EMB-Z2530PA Evaluation Kit (Including EMB-Z2531PA-USB/IA)

## 7 Disclaimer

The user must read carefully all the documentation available before using the product. In particular, care must be taken in order to comply with the regulations (i.e. power limits, duty cycle limits, etc.).

### 7.1 Handling precautions



This product is an ESD sensitive device. Handling precautions should be carefully observed.

### 7.2 Limitations

Every operation involving a modification on the internal components of the module will void the warranty.

### 7.3 Disclaimer of liability

The information provided in this and other documents associated to the product might contain technical inaccuracies as well as typing errors. Regulations might also vary in time. Updates to these documents are performed periodically and the information provided in these manuals might change without notice. The user is required to ensure that the documentation is updated and the information contained is valid. Embit reserves the right to change any of the technical/functional specifications as well as to discontinue manufacture or support of any of its products without any written announcement.

### 7.4 Trademarks

Embit is a registered trademark owned by Embit s.r.l.

All other trademarks, registered trademarks and product names are the sole property of their respective owners.