



embit

# EMB-Z2538PA

PRELIMINARY

Datasheet



---

# Index

<b>1 Description</b>	<b>4</b>
1.1 Specifications	4
1.2 Applications	4
1.3 Block diagram	5
1.4 Microcontroller	5
1.5 Antenna	5
1.6 Power Amplifier / Low Noise Amplifier	8
1.7 Firmware	9
1.8 Development Tools	9
<b>2 Size and footprint</b>	<b>10</b>
2.1 Size	10
2.2 Connector positioning	11
2.3 Footprint	12
2.4 Antenna positioning	13
2.5 Notes	14
<b>3 Connections</b>	<b>15</b>
<b>4 Typical Application Circuit</b>	<b>17</b>
<b>5 Electrical characteristics</b>	<b>18</b>
5.1 Absolute Maximum Ratings	18
5.2 Operating Conditions	18
5.3 Power Consumption	18
5.4 RF Characteristic	18
<b>6 Soldering</b>	<b>19</b>
<b>7 Compliance</b>	<b>20</b>
<b>8 Ordering informations</b>	<b>21</b>
8.1 Types	21
8.2 Packaging	21
<b>9 Disclaimer</b>	<b>22</b>
9.1 Handling precautions	22
9.2 Limitations	22
9.3 Disclaimer of liability	22
9.4 Trademarks	22

# 1 Description

**EMB-Z2538PA** is an OEM wireless module developed by **embit** for Low-Rate Wireless Personal Area Networks (LR-WPAN) applications. The module combines high performance to small dimensions and low cost, providing the system integrator a simple and easy way to add IEEE 802.15.4 / ZigBee low range wireless connectivity and multi-hop networking into existing products.

**EMB-Z2538PA** is configured as an embedded micro system or simple data modem for low power applications in the 2.4 GHz ISM band. It is based on a Texas Instruments™ CC2538 single chip device which is an ARM Cortex M3 32 bit controller with up to 512 kB of FLASH memory and 32 kB of RAM. The **EMB-Z2538PA** includes a hardware accelerator for the MAC layer (IEEE 802.15.4) and a 2.4 GHz transceiver.

The ad-hoc RF section includes a power amplifier and a low noise amplifier and delivers best-in-class performance in terms of covered area and power consumption. The output power can be increased up to +20 dBm by simple software configurations and the sensitivity is configurable between two options, allowing to cover distances up to 500 meters (LoS); the U.FL receptacle allows the connection of an external antenna.

**EMB-Z2538PA** can communicate with other devices through a wide range of serial interfaces: two UART ports, SPI, several digital I/O ports (up to 15 digital lines) and one analog port.

## 1.1 Specifications

- 32 bit ARM Cortex M3 MCU
- Up to 512kB of Flash, 32kB of RAM (of which 16 kB retention in all power modes)
- (optional) Internal additional 64kB of RAM over SPI
- (optional) Internal 32 kHz quartz
- Output power: up to +20 dBm (100 mW)
- Sensitivity: up to -105 dBm (high sensitivity mode)
- PCB antenna (PIFA), wire connector and uFL receptacle for external antennas
- Coverage: up to 500 meters (LoS)
- Unique IEEE address (64 bit) on-board
- SMD edge connector

## 1.2 Applications

- **Metering:** thermostat, meters, remote devices, displays, central devices, etc..
- **Home/Buildings Automation:** safety systems and access control, HVAC, door/window control, lightning, etc..
- **Industrial Automation:** process control, wireless sensor networks, identification and asset tracking, etc..
- **Healthcare:** blood pressure monitoring, thermometers, ECG, etc..

## 1.3 Block diagram

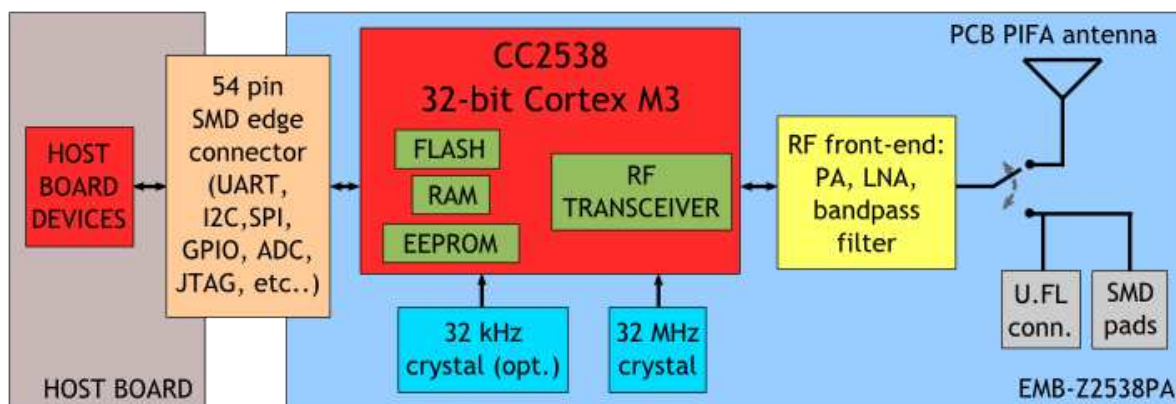


Image 1: block diagram for the EMB-Z2538PA

## 1.4 Microcontroller

EMB-Z2538PA is equipped with the latest System-On-Chip (SOC) from Texas Instruments™: the CC2538. The CC2538 is an integrated platform for IEEE 802.15.4 applications or ZigBee applications. The device integrates a low power 2.4 GHz transceiver, an MCU based on an ARM Cortex M3 core (32 bit) and a hardware accelerator for the IEEE 802.15.4 MAC layer.

The CC2538 can be used for different wireless applications, starting from simple point to point proprietary protocols up to ZigBee self-healing mesh networks, and is conceived to offer high computational power but low power consumption. It targets in particular smart metering applications.

The ARM Cortex M3 32 bit core works at 32 MHz and supports the Thumb-2 instruction set; it is coupled with 512 kB of FLASH memory and 32 kB of SRAM memory.

## 1.5 Antenna

The EMB-Z2538PA module offers three different antenna options:

- PIFA antenna directly printed on the PCB with an omnidirectional emission diagram (xz plane). The performances of this antenna are influenced by the positioning of the module in the system (see paragraph “Antenna positioning”). The antenna specifications are provided in next paragraph.
- Wire antenna: hole for soldering a wire antenna.
- External antenna connector (optional): 50 Ohm single ended U.FL connector.

### 1.5.1 PIFA antenna radiation diagrams

The printed antenna of the **EMB-Z2538PA** is a simple and performant solution for a 2,4 GHz system. It has a maximum gain of +1,5 dBi, positioned in the xy plane perpendicular to the module (see 3D radiation diagram).

Here is the 3D radiation pattern:

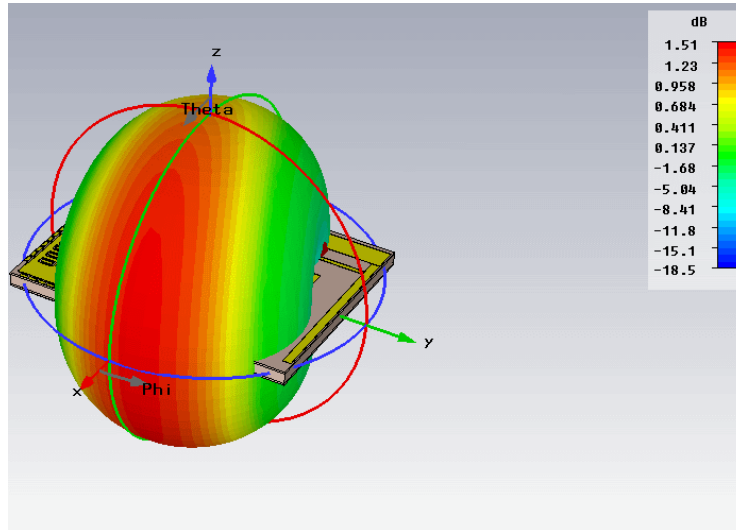


Image 2: 3D radiation pattern

Polar radiation pattern:

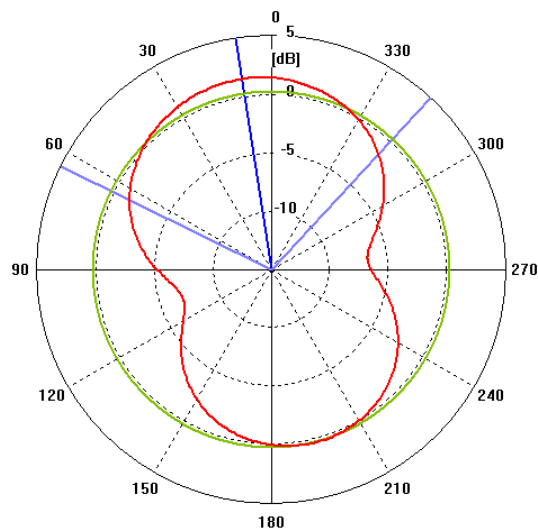


Image 3: polar radiation pattern, xy plane

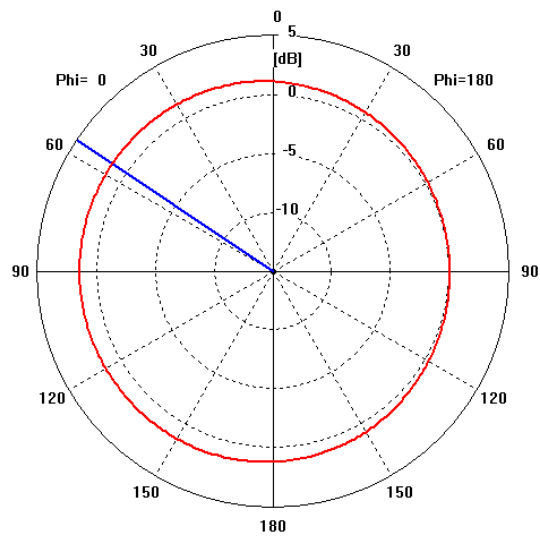


Image 4: polar radiation pattern, yz plane

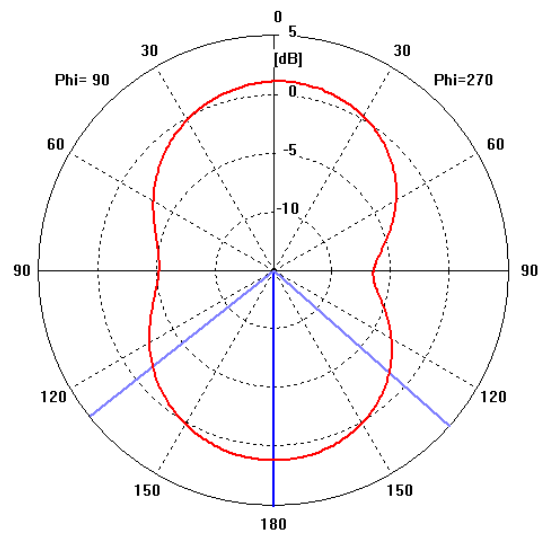
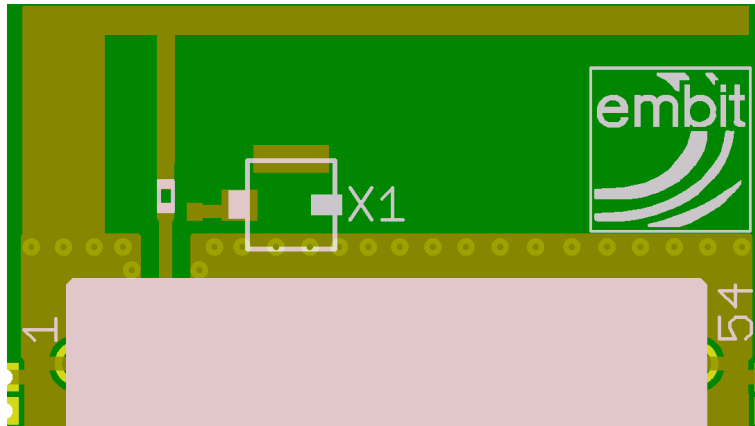


Image 5: polar radiation pattern, xz plane

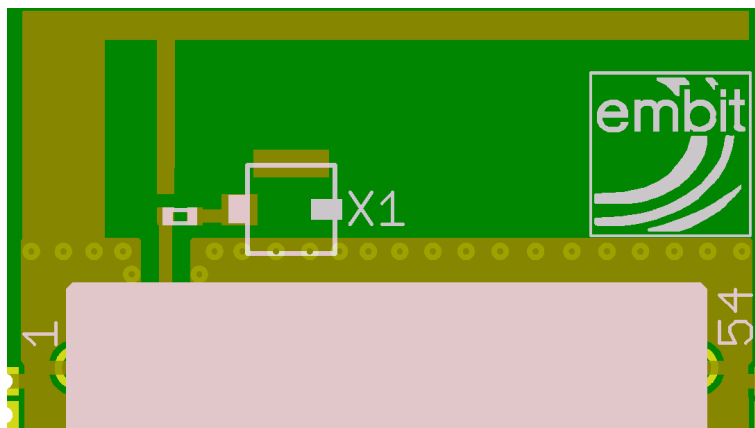
### 1.5.2 Antenna selection (PIFA/external)

To select the antenna option the last 0402 resistor (zero R) or capacitor (10 pF) in the RF chain (the one closer to the printed antenna) must be rotated from vertical to horizontal position and viceversa. If the PIFA antenna is desired, the component must be installed in vertical position, as shown in the following picture:



*Image 6: C3 capacitor installation for PIFA antenna*

If an external antenna is to be used, either through U.FL connector or wire soldering point, the C3 capacitor must be installed in horizontal position, as shown in the following picture:



*Image 7: C3 capacitor installation for external antenna*

## 1.6 Power Amplifier / Low Noise Amplifier

The **EMB-Z2538PA** module is equipped with a PA / LNA combination to increase the communication range of the device. The PA provides a fixed gain of +20 dBm and the LNA can provide a gain of +11 dBm or +1 dBm selectable from the MCU. To switch between low gain and high gain the MCU must drive the pin 0 of port R low (high gain) or high (low gain).

## 1.7 Firmware

The EMB-Z2538PA is compatible with the TIMAC stack (which can be used to develop IEEE 802.15.4-based applications) and the Z-Stack (which can be used to develop ZigBee applications) provided by Texas Instruments™. Some modifications to these stacks are required in order to drive the PA and LNA available on the EMB-Z2538PA, as described below.

### 1.7.1 Power Amplifier Interface

The **EMB-Z2538PA** has an integrated power amplifier (PA) and low noise amplifier (LNA) that must be controlled by the transceiver. Depending on the stack some modifications might be required in order to control the front-end. The interface between transceiver and front-end is composed of an SPI port and three GPIO pins: “Enable”, “PA\_enable” and “Low/High\_Sensitivity”.

The “Enable” pin (for controlling the LNA) is remapped to PC2 while the “PA\_enable” pin is remapped to PC3. The right settings for OBSSEL3 and OBSSEL2 must be changed in `mac_radio_defs.c` of the TIMAC stack:

```
/* PC3 -> PAEN */
RFC_OBS_CTRL0 = RFC_OBS_CTRL_PA_PD_INV;
OBSSEL3       = OBSSEL_OBS_CTRL0;

/* PC2 -> EN (LNA control) */
RFC_OBS_CTRL1 = RFC_OBS_CTRL_LNAMIX_PD_INV;
OBSSEL2       = OBSSEL_OBS_CTRL1;
```

More information is available in the documents provided with the EMB-Z2538PA-EVK, or you can contact EMB firmware support.

### 1.7.2 Switches and LEDs

Depending on the board in which the **EMB-Z2538PA** module will be mounted, some remapping in the TIMAC/Z-stack firmware of the defines controlling LEDs and pushbuttons might be required.

More information is available in the documents provided with the EMB-Z2538PA-EVK, or you can contact EMB firmware support.

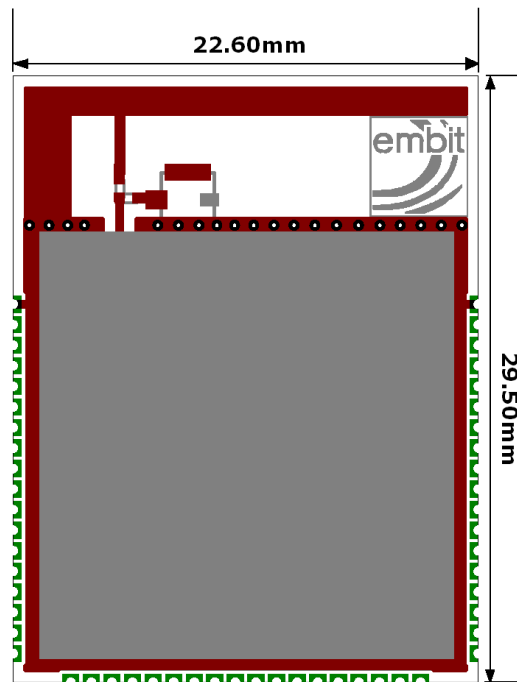
## 1.8 Development Tools

To program the EMB-Z2538PA any programmer compatible with ARM Cortex M3 architecture can be used. EMB suggests the use of the Segger J-Link and the TI XDS100v3 programmers. The IAR Embedded WorkBench for ARM IDE is needed to develop applications employing the Texas Instruments™ TIMAC and Z-Stack firmware packages.

## 2 Size and footprint

### 2.1 Size

The mechanical dimensions of the EMB- Z2538PA are identical to the dimensions of all other Embit modules: 29.50 x 22.60 mm. The thickness is 3.6 mm (CAN Shield included).



*Image 8: Outline*

## 2.2 Connector positioning

The EMB-Z2538PA module has three 18 pin “edge” connector with a 1,00 mm pitch, for a sum of 54 contacts. Each pin is a metallized half hole 0,50 mm in diameter. The positioning of the connector is shown in the following images:

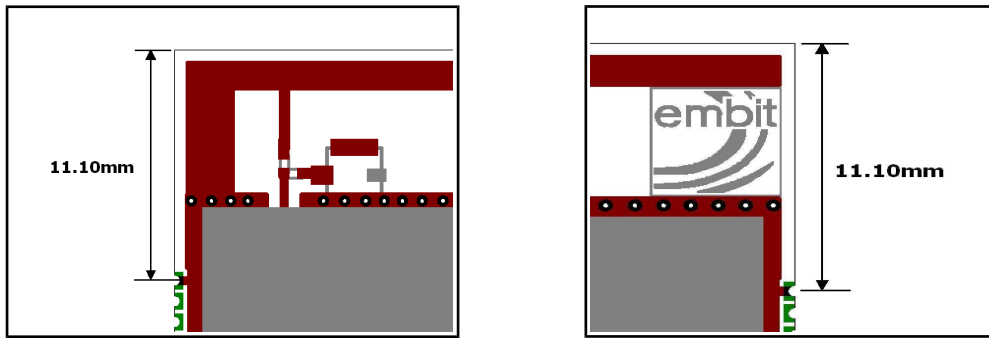


Image 9: Connector positions

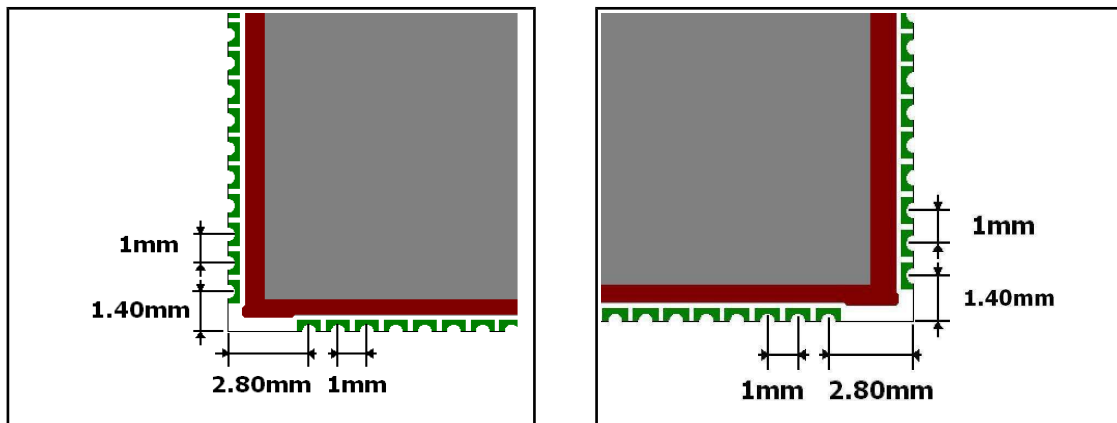
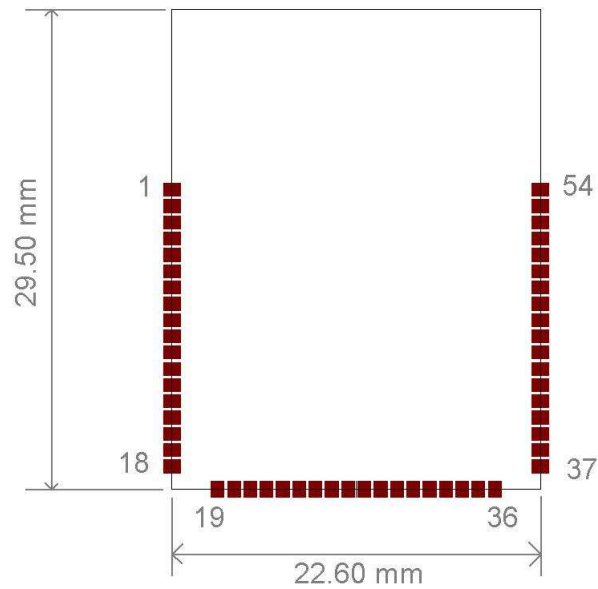


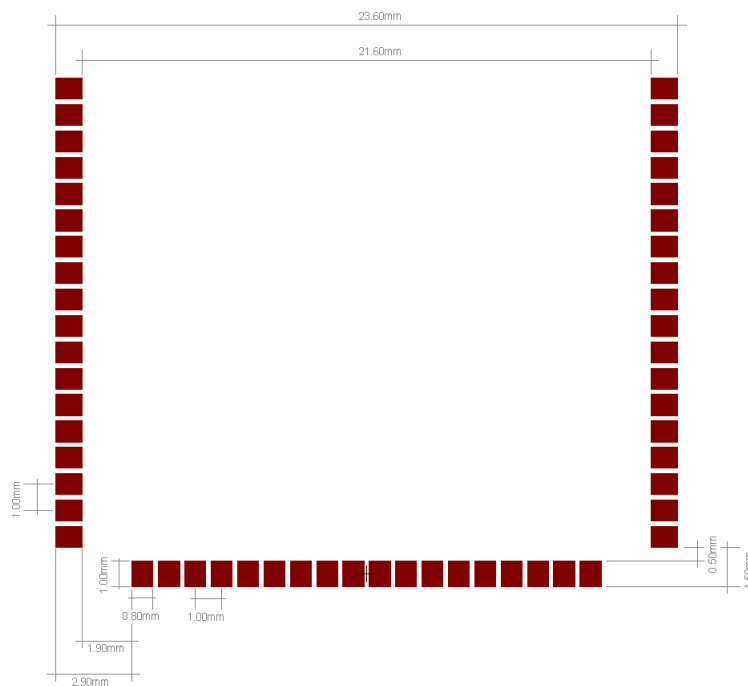
Image 10: Connector positions

## 2.3 Footprint

The EMB-Z2538PA footprint consists of 54 SMD pads with size 1,00 x 0,80 mm positioned as following:

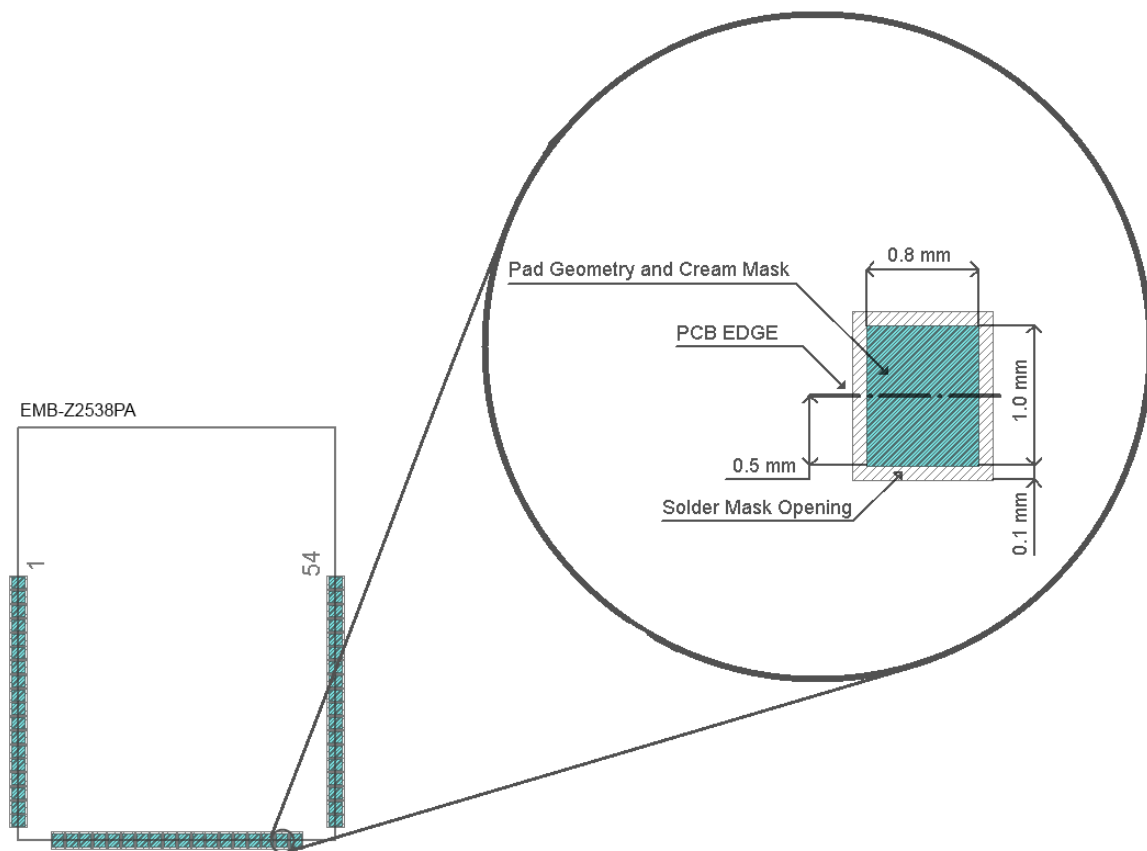


*Image 11: Footprint EMB-Z2538PA*



*Image 12: Pad distribution*

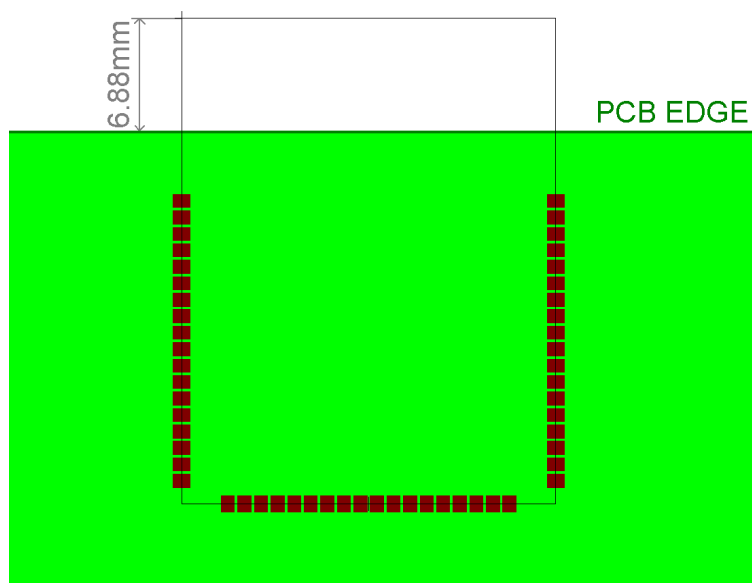
The suggested layout for the pin/pads of the **EMB-Z2538PA** is shown in the following image:



*Image 13: Details of a pin/pad layout*

## 2.4 Antenna positioning

The module must be installed on a PCB, keeping the area dedicated for the PIFA antenna outside the PCB outline. In the following image is shown an example of installation:



*Image 14: Antenna positioning*

## 2.5 Notes

- The area underneath the module must be kept free of components (both top and bottom layers) and must be covered with solder resist.
- The PCB top layer underneath the module must be free of nets, power planes and vias. The bottom layer shall provide a ground plane.
- The power supply of the module must be as clean as possible; it must be decoupled placing a ceramic capacitor as near as possible at the Vcc pins, additional filtering made by a ferrite bead is recommended.
- Noisy electronic components (such as switching power supply) must be placed as far as possible and adequately decoupled.
- The ground pins of the module shall be connected to a solid ground plane.
- Keep antenna clear of metal parts of the casing or system.
- Don't use metal enclosures to avoid RF signal degradation.

**Note:** Taking no account this recommendations may affect the radio performances.

## 3 Connections

Pin #	Pin Name	Type	Description	IC Pin #
1	GND	GND	GND	--
2	N.C.	Not connected	-	--
3	N.C.	Not connected	-	--
4	N.C.	Not connected	-	--
5	PA7_ADC0	Analog input or Digital Input/Output	ADC analog input Channel 7 / PA7	23
6	PA7_ADC0	Analog input or Digital Input/Output	ADC analog input Channel 7 / PA7	23
7	N.C.	Not connected	-	--
8	N.C.	Not connected	-	--
9	N.C.	Not connected	-	--
10	N.C.	Not connected	-	--
11	N.C.	Not connected	-	--
12	N.C.	Not connected	-	--
13	PB7_JTAG_TDO	Digital Input/Output	JTAG Data Output	48
14	PB6_JTAG_TDI	Digital Input/Output	JTAG Data Input	49
15	JTAG_TCK	Digital Input/Output	JTAG Clock	47
16	JTAG_TMS	Digital Input/Output	JTAG Mode Select	46
17	N.C.	Not connected	-	--
18	VCC	Power Input	Supply voltage	--
19	N.C.	Not connected	-	--
20	PC7_UART2_RX	Digital Input/Output	UART2 rx data input / PC7	6
21	PC6_UART2_TX	Digital Input/Output	UART2 tx data output / PC6	7
22	PA3_UART1_RTS	Digital Input/Output	UART1 request to send input / PA3	19
23	PA2_UART1_CTS	Digital Input/Output	UART1 clear to send output / PA2	18
24	PA1_UART1_RX	Digital Input/Output	UART1 rx data input / PA1	17
25	PA0_UART1_TX	Digital Input/Output	UART1 tx data output / PA0	16
26	N.C.	Not connected	-	--
27	N.C.	Not connected	-	--
28	N.C.	Not connected	-	--
29	N.C.	Not connected	-	--
30	PD2_TMR1	Digital Input/Output	Timer IO signal / PD2	27
31	PC1_TMR0	Digital Input/Output	Timer IO signal / PC1	13
32	PC1_SPI_SCK	Digital Input/Output	SPI Port Clock / PC1	13

## Connections

Pin #	Pin Name	Type	Description	IC Pin #
33	PD1_SPI_MOSI	Digital Input/Output	SPI Port MOSI / PD1	26
34	PD2_SPI_MISO	Digital Input/Output	SPI Port MISO / PD2	27
35	PC0_SPI_SS	Digital Input/Output	SPI Port Slave Select / PC0	14
36	N.C.	Not connected	-	--
37	VCC	Power Input	Supply voltage (Buck regulator & I/O buffers)	--
38	N.C.	Not connected	-	--
39	N.C.	Not connected	-	--
40	N.C.	Not connected	-	--
41	N.C.	Not connected	-	--
42	N.C.	Not connected	-	--
43	PA4_GPIO	Digital Input/Output	IO (Switch 2) / PA4	20
44	PA5_GPIO	Digital Input/Output	IO (Switch 1) / PA5	21
45	N.C.	Not connected	-	--
46	N.C.	Not connected	-	--
47	PC0_SPI_SS	Digital Input/Output	IO (LED2) / PC0 / SPI SS	14
48	PA6_GPIO	Digital Input/Output	IO (LED1) / PA6	22
49	X32K_Q2	Analog input or Digital Input/Output	Optional 32,768KHz crystal oscillator input	45
50	X32K_Q1	Analog output or Digital Input/Output	Optional 32,768KHz crystal oscillator output	44
51	RESET#	Digital Input	System reset input (active low)	28
52	N.C.	Not connected	-	--
53	N.C.	Not connected	-	--
54	GND	GND	GND	--

## 4 Typical Application Circuit

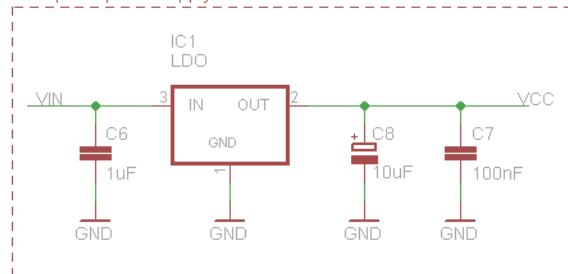
A basic application circuit for the **EMB-Z2538PA** is shown in Image 15. The **EMB-Z2538PA** allows for a minimal number of external components (thus decreasing system costs).

In Image 15 a LED indicator (LED1) and a push button (SW1) are used to provide a minimal user interface. The JTAG programming/debugging interface, generally speaking, will be routed to a connector on the host board for in-circuit programming.

In addition, a simple supply section (based on a 3.3V LDO stabilizing the input voltage VIN) and a simple reset circuitry are shown. In particular, the reset circuitry of Image 15 allows to

1. program the CC2538 MCU of the **EMB-Z2538PA** (thanks to the weak pull-up to VCC);
2. manually reset the CC2538 MCU, if needed (thanks to SW\_RESET).

Example of power supply section



Example of reset circuitry

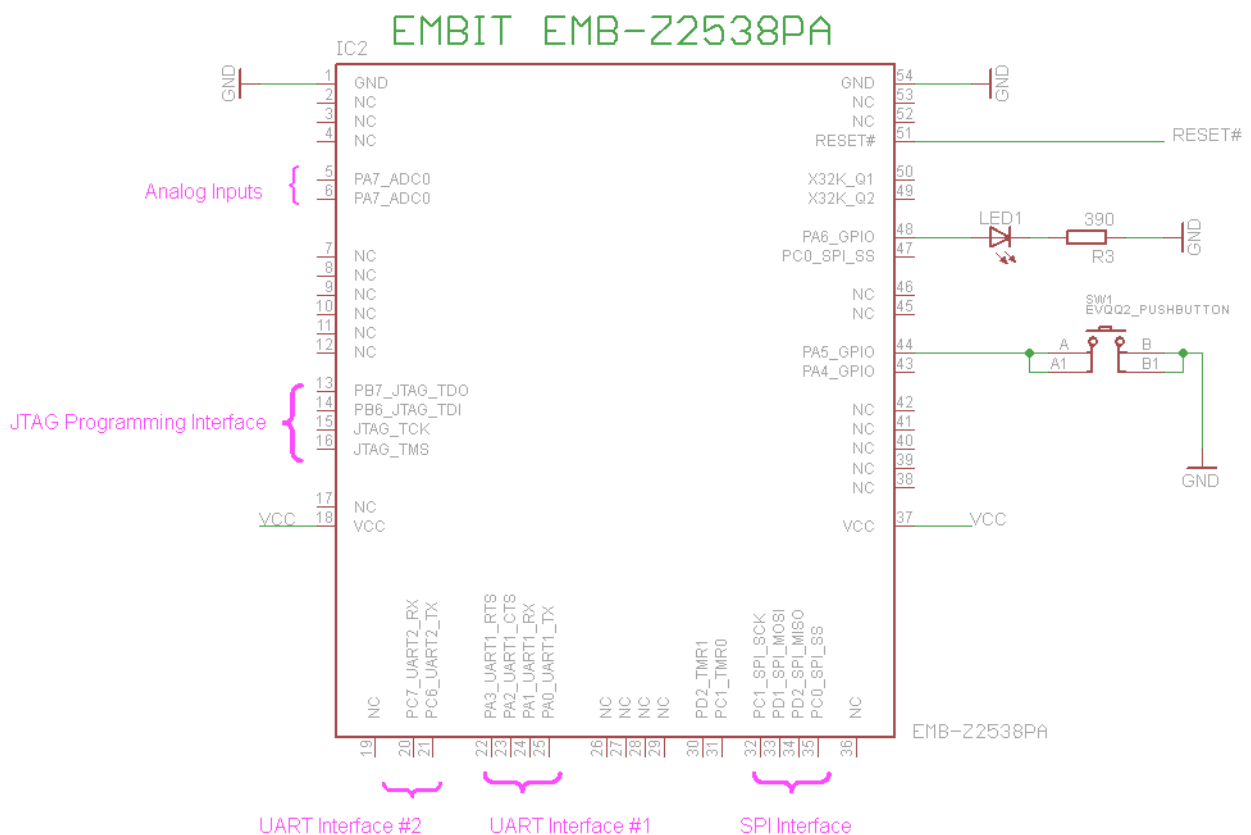
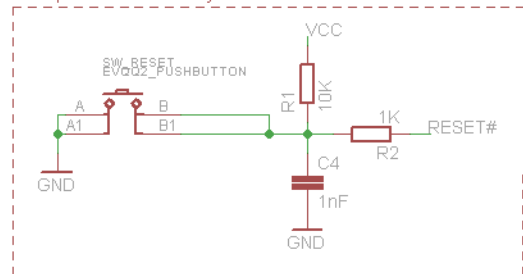


Image 15: Typical application circuit for the **EMB-Z2538PA**

## 5 Electrical characteristics

### 5.1 Absolute Maximum Ratings

	Value	Unit
Power Supply Voltage	+3,6	Vdc
Voltage on any pin	Vcc + 0,3 (Max 3,6)	Vdc
RF input power (P <sub>MAX</sub> )	10	dBm
Storage Temp. Range	-45 ~ +125	°C

### 5.2 Operating Conditions

Parameter	Min	Typ	Max	Unit
Power Supply Voltage (Vcc)	2,1		3,6	Vdc
Input Frequency	2405		2480	MHz
Operating Temperature Range	-40		85	°C
Logic Input Low Voltage (@ Vdd = 3 V)	0		0,5	Vdc
Logic Input High Voltage (@ Vdd = 3 V)	2,5		Vcc	Vdc
Logic Output Low Voltage (@ Vdd = 3 V)	0		0,5	Vdc
Logic Output High Voltage (@ Vdd = 3 V)	2,4		Vcc	Vdc

### 5.3 Power Consumption

Mode	Typ. value	Unit
Transmission @ + 20 dBm (MCU core running)	166	mA
Transmission @ + 12 dBm (MCU core running)	90	mA
Receive (MCU core running)	34.5	mA
Idle (MCU core running, radio off)	15.3	mA
Sleep (MCU core and radio sleeping)	Up to 1.7*	µA

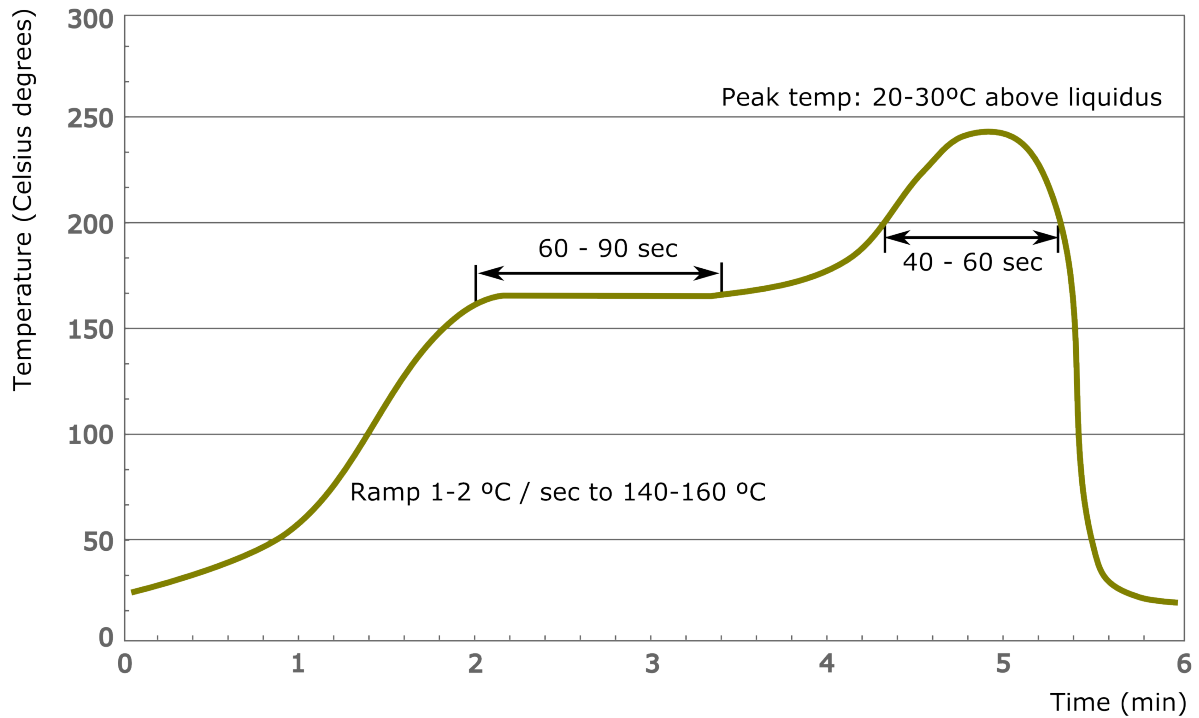
\* 1.7 µA can be obtained in power mode TBD with sleep timer running.

### 5.4 RF Characteristic

Parameter	Min	Typ	Max	Unit
RF Frequency Range	2400		2483,5	MHz
RF Data Rate		250		kbps
Nominal Output Power	--	+10	--	dBm
Programmable Output Power Range	+8	--	+20	dBm
Receiver Sensitivity (1% PER) - Normal mode	--	-94	--	dBm
Receiver Sensitivity (1% PER) - High sensitivity mode	--	-105	--	dBm
Saturation (IP3) - Maximum Input Level	-2			dBm

## 6 Soldering

Temperature profile for reflow soldering:



**Pb-Free Soldering Paste:** it is suggested to use soldering pastes that don't need later clean for residuals.

**Cleaning:** it's not suggested to clean the module. Solder paste residuals underneath the module cannot be removed.

- Water cleaning: the cleaning process using water can involve water entering underneath the module between the two PCBs creating short circuits.
- Alcohol cleaning: the cleaning process with alcohol can damage the module.
- Ultrasound cleaning: the cleaning process with ultrasound can damage the module.

It is suggested to use no clean solder paste to avoid any need for cleaning.

**Cycles:** it is suggested to do only one soldering cycle.

In case of reflow soldering, a drying bake should be done in order to prevent a popcorn effect. Re-baking should be done following IPC standards. Any unused modules that has been open for more than 168 hours or not stored at <10% RH should be baked before any subsequent reflow.

## **7 Compliance**

The module is undergoing certification. More information will be available soon.

## 8 Ordering informations

### 8.1 Types

Module variations:

Part No.	Description
EMB-Z2538PA/IA	EMB-Z2538PA integrated PIFA antenna
EMB-Z2538PA/UL	EMB-Z2538PA U.FL connector for external antenna

Related products:

Part No.	Description
EMB-Z2538PA-EVK	EMB-Z2538PA Evaluation Kit

### 8.2 Packaging

Embit's modules are delivered in tubes, each tube including 20 items.

The tube dimensions are approximately: 508mm x 33mm x 8mm.

## 9 Disclaimer

The user must read carefully all the documentation available before using the product. In particular, care must be taken in order to comply with the regulations (i.e. power limits, duty cycle limits, etc.).

### 9.1 Handling precautions



This product is an ESD sensitive device. Handling precautions should be carefully observed.

### 9.2 Limitations

Every operation involving a modification on the internal components of the module will void the warranty.

### 9.3 Disclaimer of liability

The information provided in this and other documents associated to the product might contain technical inaccuracies as well as typing errors. Regulations might also vary in time. Updates to these documents are performed periodically and the information provided in these manuals might change without notice. The user is required to ensure that the documentation is updated and the information contained is valid. Embit reserves the right to change any of the technical/functional specifications as well as to discontinue manufacture or support of any of its products without any written announcement.

### 9.4 Trademarks

Embit is a registered trademark owned by Embit s.r.l.

All other trademarks, registered trademarks and product names are the sole property of their respective owners.