

Top view:

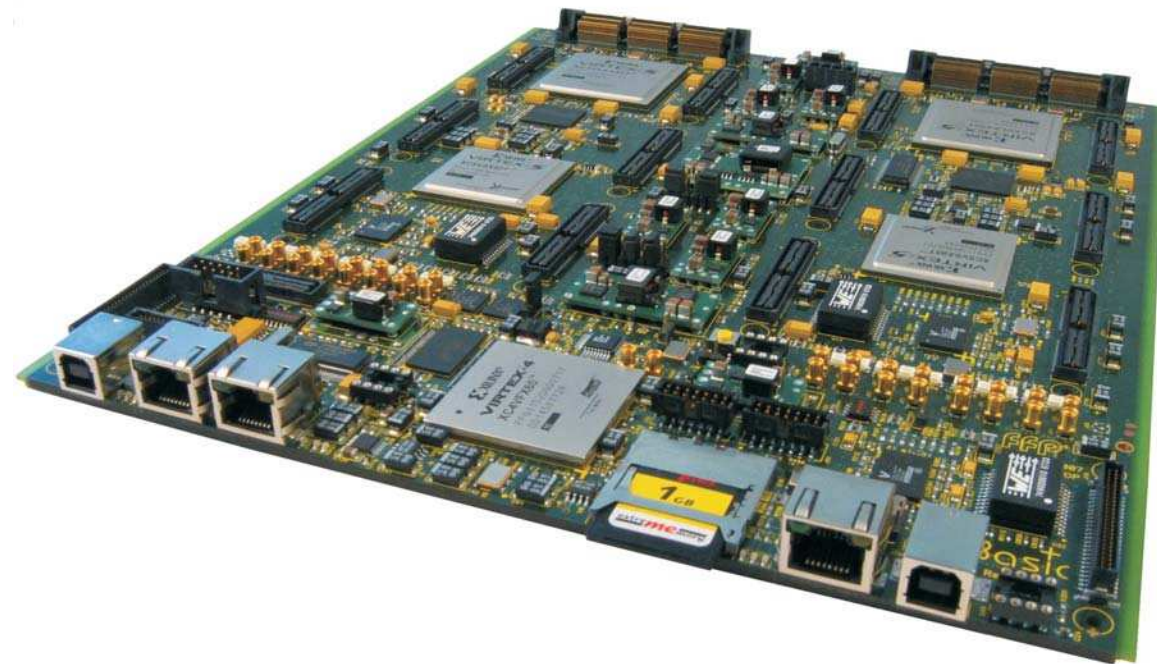

Configuration Software

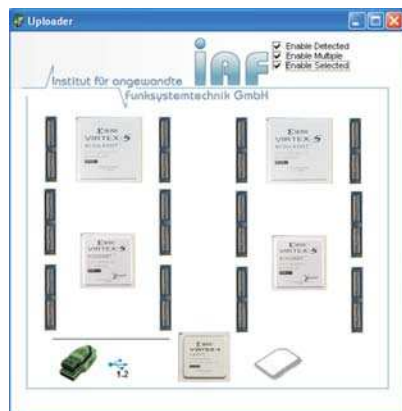

The GUI that enables all administration features looks like the picture on left.

It has an intuitive view and is easy to use. Just click on the corresponding picture to your intended action. A pop up menu will guide you to the procedure. In combination with the Hardware-in-the-Loop feature you can easily measure data inside your design and process them outside on a PC e.g. with Matlab™.

Contact: IAF GmbH
Berliner Str. 52 J
D-38104 Braunschweig
Tel: +49 531 3 79 88 - 0
Fax: +49 531 3 79 88 -30
e-mail: info@iaf-bs.de
Web: http://www.iaf-bs.de

FFP Basic+



Rapid Prototyping Board

- the ideal FPGA building set

Rapid prototyping becomes easier. By using the building set features of the **FFP** family you can gain time by launching your products. The new designed **FFP Basic+** satisfies your needs to construct a flexible and powerful prototype in a short time. Take benefit of sharing our knowledge with your plans to make it real.

Main description:

The board is equipped with 4 **Xilinx Virtex-5 FPGAs** (up to 850.000 logic cells) combined with a fast controller unit and a single 5V DC power supply. It offers a lot of user configurable I/Os over new high speed connectors. All connections support differential signal formats. Up to **6 slots for Add-On modules** give you the opportunity to complete your system with interfaces and extension units. IAF offers a variety of different modules like AD / DA converter modules (up to 1GSPS), DSP or memory extensions. For more information please visit our website at www.iaf-bs.de. Replacing these units is very easy and cost effective. Just change the parts that doesn't fit and reuse the rest for your next prototype.

The board is equipped with **fast configuration interfaces like a USB2.0 and a 1000 base T Ethernet**. This allows easy and clear administration of the **FFP Basic+** from the PC. To store configuration data permanently or make the board run stand alone a MMC Card is built in. It uses a standard FAT structure. You can put the memory card into a common card reader and edit it. The capacity of up to 2 GB can store several different configurations of FPGA code. In conjunction with a configuration shell you can manage and share complete designs.

The on board memory is another feature. **2 banks of 4M * 18 bit QDR II Ram** (4ns cycle time) offer fast storing solutions. Connecting to networks is possible by using **1000 base T Ethernet** (2 times on board).

A user programmable USB2.0 hardware interface too gives more flexibility to integrate your design in communication systems. Each FPGA is part of a **gigabit transceiver mesh** (up to 2.5 Gbit/s per lane) to share data inside your system. Additional GTP connections are ending at MMC jacks for different protocols like PCI Express.



To complete the prototyping board a powerful clock unit is integrated. It offers **3 independent PLLs** (up to 500 MHz) that can be synchronised to e.g. 10 MHz reference clock. All clock outputs are distributed over a crossbar to each FPGA in differential (up to 500 MHz) or single ended (up to 200 MHz) format. All main clock lines are routed to global clock buffers.

To combine the **FFP Basic+** with simulation models a **Hardware-in-the-Loop** feature is integrated. It consists of a data transfer bus that is managed by the controller. Flexible and powerful transmission allows easy measuring of signals or constructing a hardware cosimulation to speed up your work.

Schematic diagram:

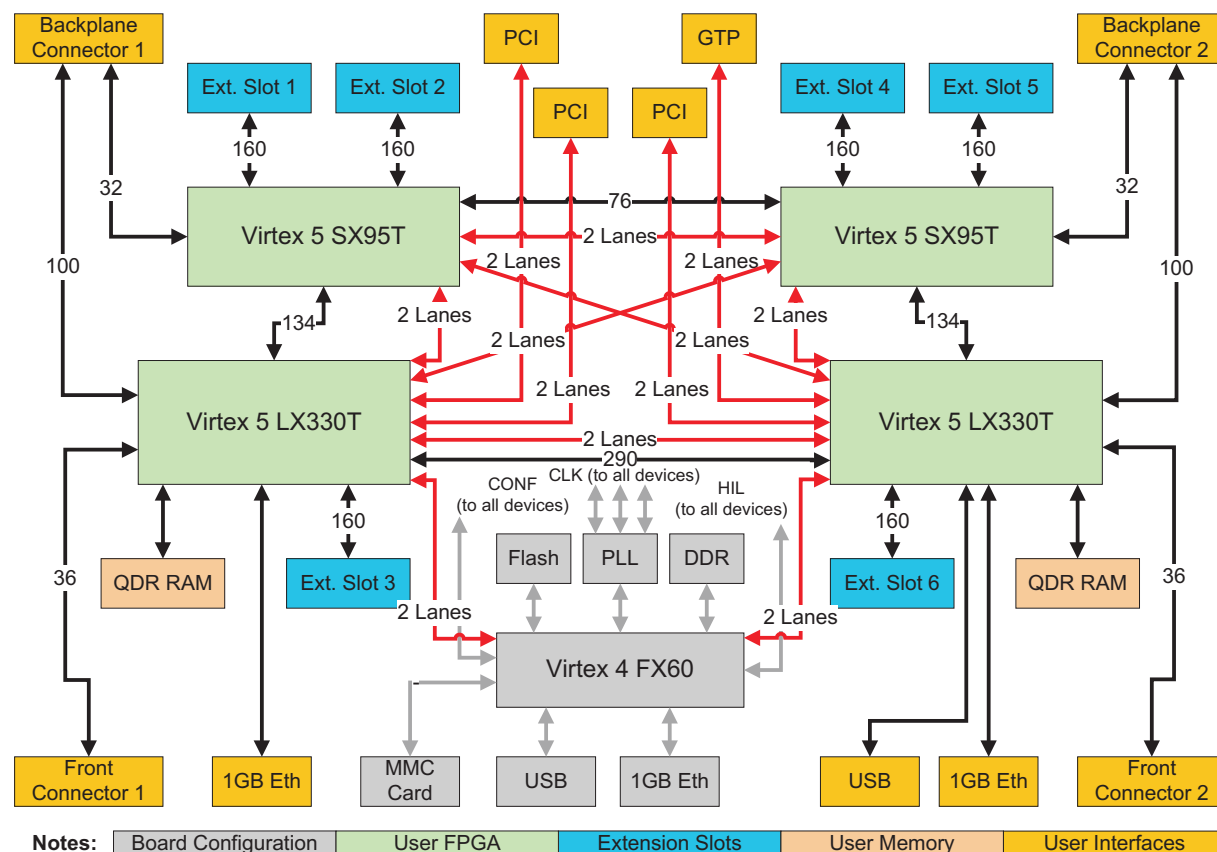

System overview:

Components

- 2 Xilinx Virtex-5 XC5VLX330T - XC5VLX110T devices with up to 286 interconnections
- 2 Xilinx Virtex-5 XC5VSX95T - XC5SX55T devices with up to 76 interconnections
- 1 Xilinx XC4VFX60
- MMC Card interface (supports up to 2GB)
- 2 RAM blocks 4M * 18bit QDR II SRAM

Connectors

- 2 Samtec QTS 075 backplane connector (with 150 pins up to 2 GHz)
- 2 ERNI SMC connector with 50 pins
- 6 extension slots with 160 pins as high speed connector (up to 1,6 GHz) for 6 daughter boards (dimensions 90 mm*60 mm)
- 32 MMCX jacks for 8 bidirectional Gigabit Transceiver I/O lanes (4 lanes as PCI Express)

Features

- 3 integrated PLL up to 500 MHz
- USB 2.0 interface
- 2 Ethernet 1000 Base T interface
- JTAG interface for programming and debugging of FPGAs
- GTP interconnection network (2 lanes up to 2.5 Gbit)
- I²C configuration register
- User configurable 2 colour LEDs
- Manual configuration switch
- 5 V DC single external power supply

Software features

- Download FPGA program into chip or into memory card
- Data exchange between PC and FPGAs using USB interface
- Configurable mode (auto load FPGA, manual download, data exchange)
- Flexible administration of configuration modes

Mechanical dimensions: [depth * width]: 280mm * 234mm (6HE)

A summary of logic resources of the **FFP** family gives the following table:

Item	FFP Basic	FFP Basic+
FPGA	2 x VirtexIpro 100	2 x Virtex5 LX330T + 2 x Virtex5 SX95T
Logic Cells	200.000	850.000
Block RAM	16 MBit	38 MBit
Distr. RAM	2,75 MBit	9,88 MBit
DSP Slices	888	1664
Ext. RAM	2 MByte (SRAM)	18 MByte (QDR)
Ext. Slots	4	6
Gbit Ethernet	-	2
Rocket GTP	4 Channels Duplex	4 Channels Duplex
Configuration	Flash (single configuration)	MMC card (multiple configuration)