

# AMC-3D74

## DATASHEET

An optimised and highly integrated AMC card, designed for next generation applications

State of the art DSP and FPGA processing performance

Multiple 10 Gbps Serial RapidIO and Gigabit Ethernet connections

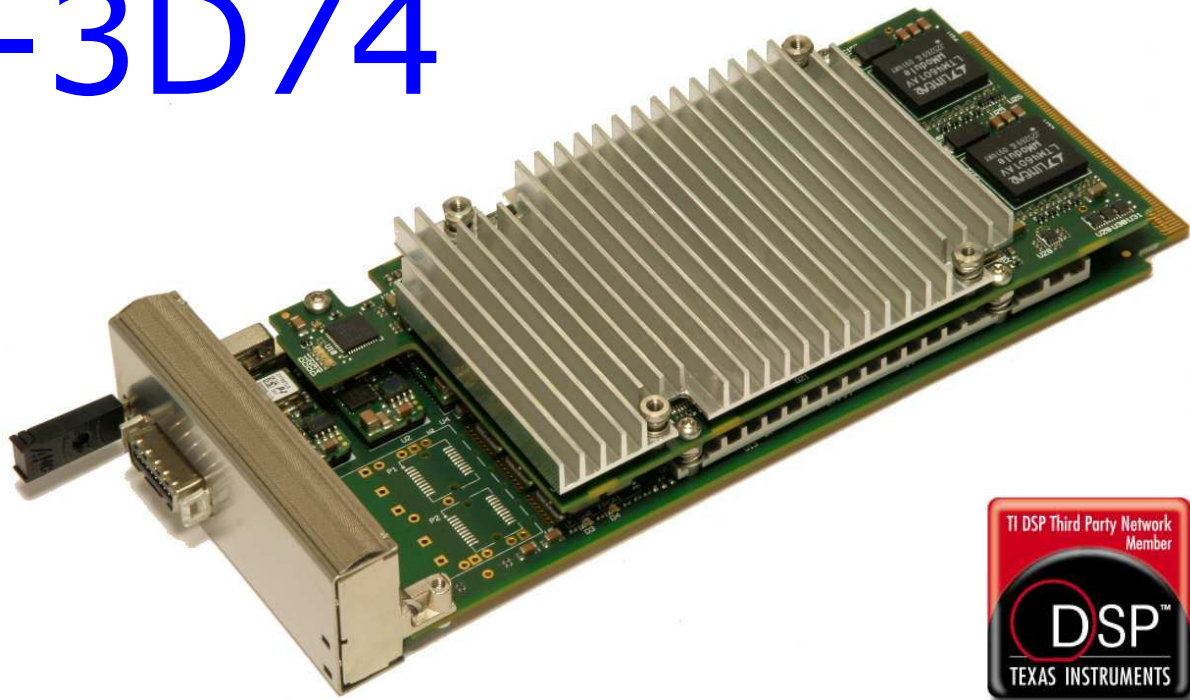

### KEY FEATURES

- Three Texas Instruments TMS320C6474 multi-core DSPs running at 1GHz
- Xilinx Virtex-5 LX110T-2 FPGA, customer programmable (alternatives also possible)
- 10 Gbps 4x Serial RapidIO infrastructure including front panel connector
- Full Gigabit Ethernet infrastructure
- Single width, full-size PICMG AMC.0 R2.0 Advanced Mezzanine Card
- Software and firmware library support
- Developed for use in OEM products
- Fully supported with customisation options and OEM lifecycle services

### RESULTING BENEFITS

- ⇒ High performance DSP resource for the latest wireless baseband applications
- ⇒ Flexible FPGA resource for interfacing and DSP co-processing
- ⇒ Dependable high-bandwidth interconnect both on and off card
- ⇒ Industry standard interconnect
- ⇒ Works with Industry standard MicroTCA chassis and ATCA cutaway carriers
- ⇒ Fast route to application code porting
- ⇒ Reduces risk and speeds time to market
- ⇒ Allows a detailed fit to specific OEM requirements

The CommAgility AMC-3D74 is a single width, full-size Advanced Mezzanine Card with exceptional processing performance and bandwidth, for the latest high performance applications such as LTE, wireless test, instrumentation, medical and imaging. A total of nine 1GHz DSP cores and a powerful Xilinx Virtex-5 FPGA allow an application to be partitioned and optimised for most effective use of system resources.

A full 10 Gbps AMC.4 SRIO infrastructure provides the deterministic bandwidth needed for radio or other raw data transfers on and off card. Separate AMC.2 Gigabit Ethernet is provided for control, management and delivery of baseband or other processed data streams. Additional high speed I/O is provided to the front panel using a CX4 connector for 4x SRIO.

A range of build options are available, and further customisation is possible in volume, to enable the best technical and commercial fit to a customer application to be achieved.



CommAgility Ltd  
sales@commagility.com  
www.commagility.com  
Tel: +44 1509 228866

Comm (( ))  
**Agility**

## HARDWARE SPECIFICATIONS

**FPGA:** Xilinx Virtex-5™ FPGA, standard configuration is LX110T-2. With:

- 128 Mbytes of x16 DDR2-600 SDRAM
- 128 Mbytes of parallel FLASH
- 10 Gbps 4x SRIO
- 2 Full-duplex Gigabit Ethernet ports
- 4 RocketIO™ high speed serial ports to AMC backplane ports 17-20
- Inputs or outputs to AMC TCLKA-D ports

**DSPs:** Three 1 (or 1.2) GHz multi-core TMS320CI6474 DSPs. Each DSP has:

- 256 Mbytes x16 DDR2-667 SDRAM
- Two 1x SRIO ports to switch
- One Gigabit Ethernet port to switch
- DSP boot over SRIO or Ethernet
- Reset, bootmode, endian-ness and L2 cache controlled from FPGA
- McBSP, Timer and GPIO pins to FPGA

**Serial RapidIO:** 10Gbps 4x infrastructure using IDT Tsi578™ switch:

- AMC.4 compliant 10 Gbps 4x connections to AMC ports 4-7 and 8-11
- Dedicated 10 Gbps 4x link to FPGA
- Two 1x SRIO ports to each DSP
- 4x port to front panel

**Ethernet:** Gigabit Ethernet infrastructure using Broadcom BCM5389™ switch:

- AMC.2 (1000BASE-BX) compliant connections to AMC Ports 0 & 1
- Full-duplex 1 Gbps links

**Debug:** DSP or FPGA JTAG debug via CommAgility Breakout Board (AMC-BB).

**IPMI:** ATmega128 IPMI controller:

- AMC.0 IPMB\_L interface
- FRU EEPROM data
- Power & reset control, health monitoring

**Form Factor:** Advanced Mezzanine Card

- AMC.0 Rev 2.0 compliant
- Full-size, single-width
- AMC.2 GigE and AMC.4 4x SRIO
- Hot swap support

## ENVIRONMENTAL/EMC/SAFETY

- Operating temperature: 0-40°C ambient
- Power consumption: up to 48W max, dependent on DSP and FPGA load
- Designed for NEBS and ETSI compliance when used in appropriate chassis
- 2004/108/EC and FCC EMC compliant
- 2002/95/EC RoHS, 2002/96/EC WEEE and 2006/95/EC Low Voltage Directive compliant

## SOFTWARE

**FPGA:** to demonstrate configuration and functionality; Xilinx ISE and EDK project

**MicroBlaze Board Support Library:** support for board setup and interfaces, self test and FLASH update

**DSP Board Support Library:** for DSP setup and interfaces

**MMC:** full management suite based on Pigeon Point BMR software

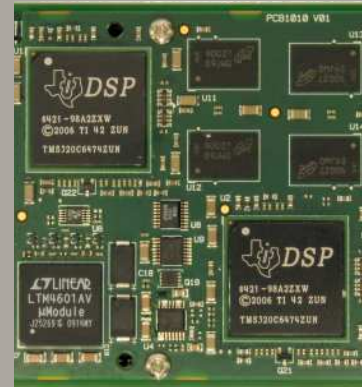

## OEM PARTNERSHIP SERVICES:

**IN DEVELOPMENT**  
Support and training; hardware customisation; software and FPGA development.

**IN MANUFACTURE**  
Lead-time reduction through stocking components or products; extended warranty and repair; quick turn repairs and/or spares stocking. Licensing of designs considered for high volumes.

**DURING LIFECYCLE**  
Guaranteed lifecycle; obsolescence management; design information held in Escrow.

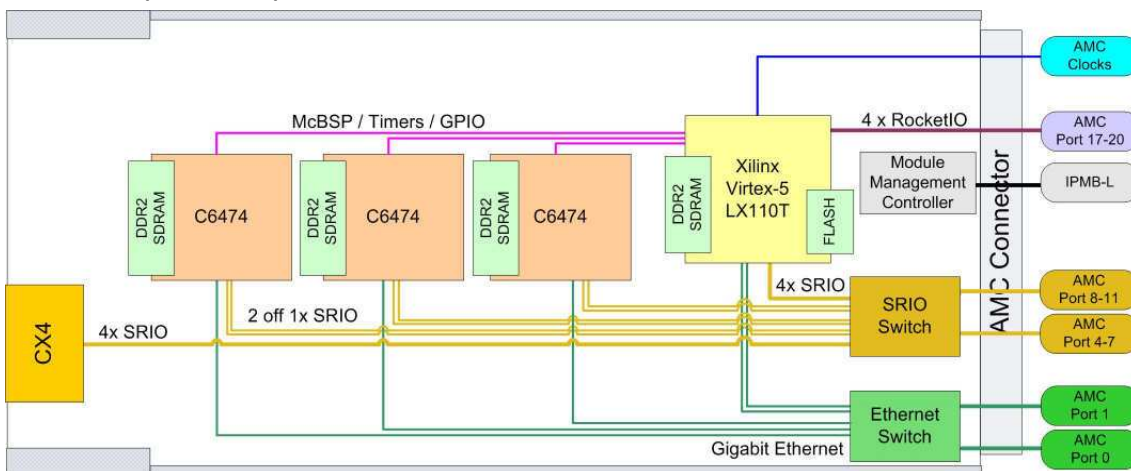

**AdvancedMC™**

**μTCA®**

**AdvancedTCA®**



CommAgility Ltd, Loughborough, UK  
Tel: +44 1509 228866  
World-wide support details:

sales@commagility.com  
www.commagility.com  
www.commagility.com/contact

