

AMC-RF2x2

DATASHEET

A wideband, highly flexible 2x2 RF AMC Module aimed at LTE and LTE Advanced applications

High quality RF, suitable for Test Equipment as well as R&D, Demonstrators and Trial systems

Can be used along with CommAgility L1/L2 DSP AMCs for complete MicroTCA LTE systems

Flexible FPGA-based architecture with separate RF modules allows customisation



KEY FEATURES

- Wideband RF, 662 to 3839MHz
- RF bandwidths up to 40 MHz
- Supports 2x2 MIMO as standard
- Tx power output up to +10dBm
- High quality RF (details overleaf)
- FDD and TDD modes
- Multiple I/O modes: separate, switched, combined or loopback
- NCO fine frequency control to <1Hz
- Separate TX and RX power sensors
- Sync via CPRI, FP or AMC clocks
- FPGA with SDRAM and FLASH for control and IQ data processing
- Two CPRI (RE, V4.2) front panel ports, baud rates up to 6.144 Gbps
- Gigabit Ethernet and AMC fat pipe connections to AMC backplane

RESULTING BENEFITS

- ⇒ Supports all LTE bands
- ⇒ Bandwidths for LTE Advanced
- ⇒ Reduced space, weight and power
- ⇒ Supports Test and indoor operation
- ⇒ Suitable for Test equipment
- ⇒ World-wide operation
- ⇒ Covers a range of Test and other applications; allows self calibration
- ⇒ Highly accurate RF frequency
- ⇒ Accurate power measurement
- ⇒ Flexible system integration
- ⇒ Performance for digital baseband processing; flexibility for updates
- ⇒ CPRI capacity to support the full RF bandwidth and performance
- ⇒ Ability to customize for non-CPRI interfaces, e.g. GigE, XAUI, PCIe, SRIO

The CommAgility AMC-RF2x2 is a high performance RF interface card in the compact and popular Advanced Mezzanine Card form factor. It is tunable across the full set of LTE bands with no hardware changes, has up to 40MHz RF bandwidth, and a single unit is capable of 2x2 MIMO. This makes it ideal for a wide range of LTE and LTE Advanced wireless applications, whether Test Equipment, R&D or trial systems.

The card is supplied fully integrated with on-board firmware and software to manage the RF and interface IQ data to CPRI, and a modular approach to the RF circuitry allows customisation for different power levels or to add banded duplexing or filtering.



CommAgility Ltd
sales@commagility.com
www.commagility.com
Tel: +44 1509 228866



CommAgility

HARDWARE SPECIFICATIONS

FPGA:

- Xilinx Virtex-6 LX75T-2 FPGA
- 256 MBytes 16-bit DDR3 SDRAM
- 128 MBytes FLASH
- CommAgility provided FPGA firmware
- Control via CPRI or Gigabit Ethernet
- I/Q data via CPRI, others possible
- Timing from CPRI, FP or AMC clocks

Front panel I/O:

- 2 x SFPs to FPGA: CPRI Rev 4.2 RE ports, up to 6.144 Gbaud rate
- Clock and Trig I/O ports (SMB)
- RF: 2 x Tx, 2 x Rx/Tx ports (SMA)

Backplane I/O to FGPA:

- Ports 0,1 (Gigabit Ethernet)
- Ports 4-7 and 8-11 (fat pipes)
- AMC TCLKs and FCLK to FPGA

Module Management Controller:

- AMC.0 IPMB_L, FRU EEPROM data, power and reset, health monitoring, based on Pigeon Point™ BMC software

Form Factor:

- Single-width, full-size Advanced Mezzanine Card, AMC.0 Rev 2.0
- Chassis and logic ground bridged

Environmental and Compliance:

- Operating temp: 0-40°C ambient
- Power consumption: estimated 20W
- 2004/108/EC and FCC EMC compliant
- 2002/95/EC RoHS, 2002/96/EC WEEE and 2006/95/EC LVD compliant

RF SPECIFICATIONS

Frequency and Bandwidth:

- RF Freq Range: 662—3839MHz
- RF Fine Freq Resolution: <1Hz
- RF Bandwidths supported: 1.4, 3, 5, 10, 15, 20, 40+ MHz
- Base-band sampling: 122.88 MSPS

Front End Modes:

- Separate Tx and Rx (FDD)
- Combined Tx/Rx (FDD)
- Switched Tx/Rx (TDD)
- Loopback Tx to Rx (calibration)

TX Ports:

- Maximum Tx power: +10dBm (CW)
- Tx Dynamic Range: >60dB
- EVM: <2% (5MHz BW, Pout <0dBm)
- Power sensor range: -50dBm to 0dBm
- Power sensor accuracy: 0.5dB
- DAC SFDR: >70dB

RX Ports:

- Maximum input power (OFDM): +4dBm (EVM <8%)
-15dBm (EVM <2%)
+30dBm (absolute maximum)
- Gain range: 60dB
- EVM: <2% (5MHz BW, -15dBm > Pin > -65dBm)
- Power sensor range: -50dBm to 0dBm
- Power sensor accuracy: 0.5dB

Calibration and tuning:

- Power sensors factory calibrated over multiple power levels and frequencies
- Auto-tune of other RF parameters on frequency change or user request

Potential Customisations:

- Increased output power level
- Filtered and/or duplexed I/O
- IQ data via SRIO or PCI Express
- 4x MIMO synchronized TX and RX

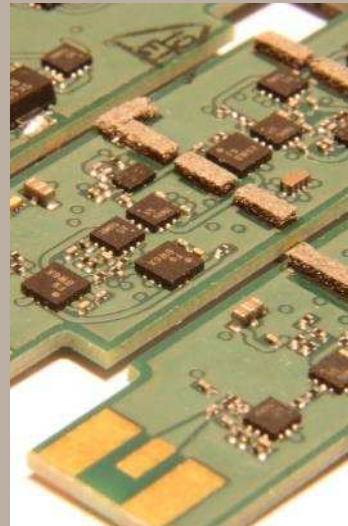

OEM PARTNERSHIP SERVICES:

IN DEVELOPMENT: Support and training; hardware customisation; software and FPGA development.

IN PRODUCTION: lead-time reduction; extended warranty; and repair; quick turn repairs and/or spares stocking.

EXTENDED LIFE: obsolescence management; guaranteed lifecycle; Escrow.

LICENSING is offered for high volume projects.

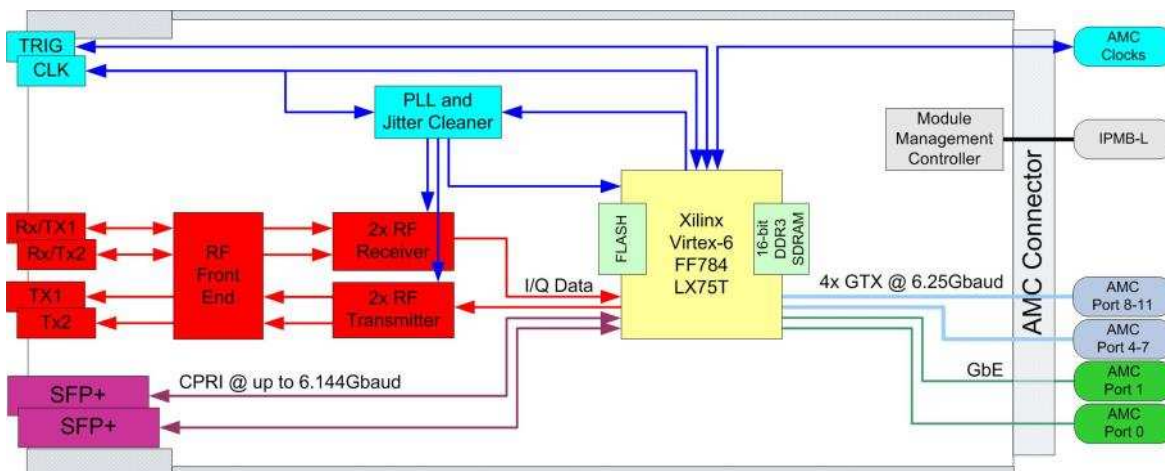

AdvancedMC™

μTCA®

AdvancedTCA®



CommAgility Ltd, Loughborough, UK
Tel: +44 1509 228866
World-wide support details:

sales@commagility.com
www.commagility.com
www.commagility.com/contact

