

# AMC-V7-2C6670

## DATASHEET

A high performance AMC card based on a Xilinx Virtex-7 and TI's TMS320C6670 DSPs, with high speed, flexible I/O

8 DSP cores with shared memory and additional wireless accelerators, ideal for a range of high performance DSP applications

Front panel I/O: 3x SFP+ to FPGA or DSPs. GPS receiver. Front panel or AMC clock sync

Flexible, high bandwidth off-board communications via Gen2 Serial RapidIO



### KEY FEATURES

- Xilinx Virtex-7 FPGA, XC7VX415T-2
- Dual TMS320C6670 quad-core DSPs
- Multiple banks of DDR3 SDRAM for both DSPs and FPGA
- Flash memory
- IDT CPS-1848 Serial RapidIO switch
- On-board Ethernet switch
- Separate "glue logic" for board configuration and management
- Three front panel SFP+ optical interfaces, to the FPGA GTH or DSP AIF2
- Optional GPS receiver
- Timing and synchronisation from front panel or backplane clock I/O
- Single width Full Size PICMG AMC.0 R2.0 Advanced Mezzanine Card

### RESULTING BENEFITS

- ⇒ Cost effective, high density device
- ⇒ The latest high performance TI DSPs
- ⇒ Latest external memory technology with multiple high bandwidth buses
- ⇒ Stores multiple FPGA images & software
- ⇒ SRIO V2.1 at up to 25 Gbaud per port
- ⇒ Gigabit Ethernet to all main devices
- ⇒ Allows control, FPGA configuration and FLASH reprogramming over SRIO/SPI
- ⇒ Flexible high-speed optical links, suitable for a range of applications
- ⇒ Highly accurate timing sync
- ⇒ Syncs easily to other equipment
- ⇒ Works with industry standard MicroTCA chassis; can also run standalone

The CommAgility AMC-V7-2C6670 is a high performance DSP/FPGA based processing card in the extremely compact Advanced Mezzanine Card form factor. It is powered by two of the latest Texas Instruments TMS320C6670 DSPs plus a high-density Xilinx Virtex-7 FPGA. It is ideal for a range of high performance DSP/FPGA wireless processing applications including LTE, LTE Advanced and beyond.

Serial RapidIO at up to 25 Gbaud per port is supported by an IDT CPS-1848 Gen2 SRIO switch. As standard, the board provides three front panel SFP+ optical interfaces that links either to the FPGA or to the DSP AIF2 ports. Timing and synchronisation is achieved via the front panel or backplane clock I/O, or optional GPS receiver.



CommAgility Ltd  
sales@commagility.com  
www.commagility.com  
Tel: +44 1509 228866

Comm (( ))  
**Agility**

# Comm (Agility)

## HARDWARE SPECIFICATIONS

**DSP:** 2 x TMS320C6670 Rev 2 DSPs, each with:

- 1.2 GHz clock speed
- 2 Gbytes x64 DDR3-1333 SDRAM
- 20 Gbaud, 4x SRIO V2.1 link to switch
- 10 Gbaud, 2x PCI Express link to FPGA
- Hyperlink50 bus (to other DSP)
- Single Gigabit Ethernet link to switch

**FPGA:** Xilinx Virtex-7™ X415T-2 FPGA

- 512 Mbytes x16 DDR3-800 SDRAM
- 1 Gbyte x32 DDR3-1250 SDRAM
- 256 Mbytes x16 NOR FLASH
- Dual 20 Gbaud 4x SRIO V2.1 to switch
- Three Gigabit Ethernet links to switch
- 4x GTX to AMC ports 20-17
- Configuration from FLASH or SRIO

**Glue:** Embedded glue logic for configuration of FPGA, general board control, Flash update. Controlled from SRIO or SPI.

### Timing:

- Front panel clock input or output
- AMC Telecom clock A-D support
- Optional GPS receiver for timing sync
- Configurable PLL and jitter cleaner based on TI CDCE62005 device

### Front panel I/O:

- 3x SFP+ to FPGA at up to 10.3 Gbaud
- Alternative build option, 3x SFP+ to DSP AIF2 at up to 5 Gbaud
- SMB for sync clock I/O

### Form Factor and Backplane:

- Single-width, full-size Advanced Mezzanine Card, AMC.0 Rev 2.0 compliant
- IDT CPS-1848™ Rev C switch for AMC.4 compliant 25 Gbaud x4 connections to AMC ports 4-7 and 8-11
- Broadcom BCM5389 switch for AMC.2 compliant GigE to AMC Ports 0 and 1
- Hot swap support

### Debug:

- Breakout board for debug and RS-232
- Separate FPGA JTAG debug connector
- RS-232 headers, LEDs for each DSP
- Optional MICTOR connector to FPGA

### Module Management Controller:

- AMC.0 IPMB\_L, FRU EEPROM data
- Power & reset, health monitoring

### ENVIRONMENT/EMC/SAFETY

- Operating temp: 0-40°C ambient
- Power consumption: up to 50W max
- Designed for NEBS/ETSI compliance when used in appropriate chassis
- 2004/108/EC and FCC EMC compliant
- 2011/65/EU RoHS, 2012/19/EU WEEE and 2006/95/EC LVD compliant

### SOFTWARE

**Management:** Full embedded suite based on Pigeon Point™ Software

**FPGA:** Xilinx ISE/EDK project to show functionality; full MicroBlaze BSL

**DSP:** Full DSP Board Support Libraries

Contact CommAgility for further details of software partners.

### OEM PARTNERSHIP SERVICES:

**IN DEVELOPMENT:** Support and training; hardware customisation; software and FPGA development.

**IN PRODUCTION:** lead-time reduction; extended warranty; and repair; quick turn repairs and/or spares stocking.

**EXTENDED LIFE:** obsolescence management; guaranteed lifecycle; Escrow.

**LICENSING** can be offered for high volume projects.

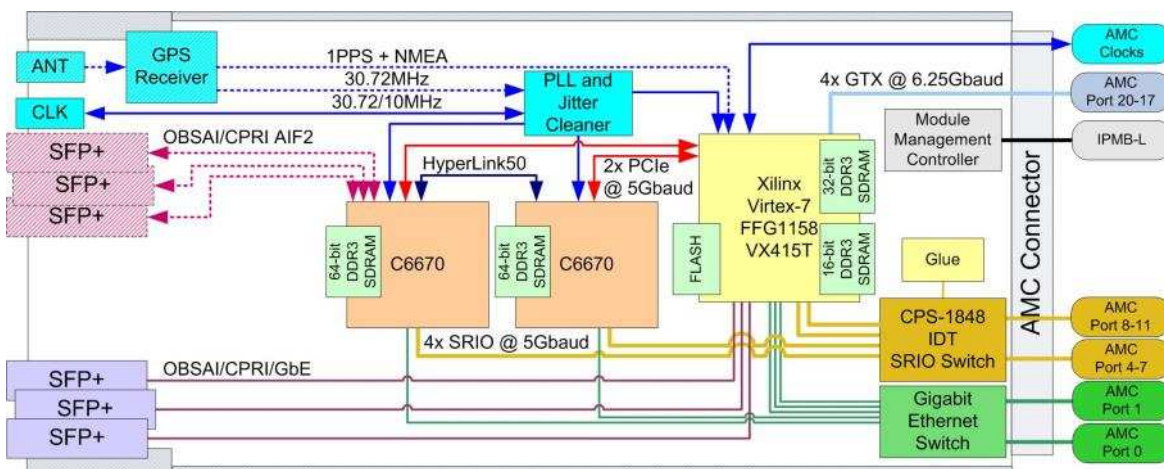

THE QUEEN'S AWARDS  
FOR ENTERPRISE  
INTERNATIONAL TRADE  
2013

**AdvancedMC™** **μTCA®** **AdvancedTCA®**

CommAgility Ltd, Loughborough, UK  
Tel: +44 1509 228866

sales@commagility.com  
www.commagility.com



Datasheet describes products in development; Information may change. AMC-V7-2C6670 P2/0114

AMC-V7-2C6670