

# SDK 4100

## DLP<sup>®</sup> Software Productivity Suite

Wintech's SDK 4100 software developer's kit, designed for Texas Instrument's D4100 and Wintech's W4100 DLP<sup>®</sup> kits, was developed to unlock the potential of DLP<sup>®</sup> Discovery chipsets. The SDK offers novice and expert users a new economical way to control all 2xLVDS chipsets offered on the DLP<sup>®</sup> Discovery platform via software and firmware. DLP<sup>®</sup> control is provided through an API, FPGA logic, and Windows drivers. The SDK 4100 allows operators to control the DMD at user defined frame rates and time averaged grayscale bit levels. The SDK also allows users to operate the DMD device at full global reset speeds for both the 0.7" XGA and 0.95" 1080p DLP<sup>®</sup> devices.



At the heart of the SDK is the high speed memory controllers that provide high speed access to the 2GB or 4GB memory modules found on the D4100 and W4100. Images are preloaded into the onboard DDR2 memory using the D4100/W4100 Cypress USB connector. These images are then extracted from memory and displayed on the DMD at user definable frame rates. The memory controllers allow for up to 22,700 binary XGA frames per second in global reset mode. The SDK includes a limited Sample GUI and user developed custom routines can be initiated using C++ or LabView programs. Support for frame triggers and frame syncs are also included. Software IP cores and licensing arrangements are available for those customers planning to move their DLP<sup>®</sup> products to production.

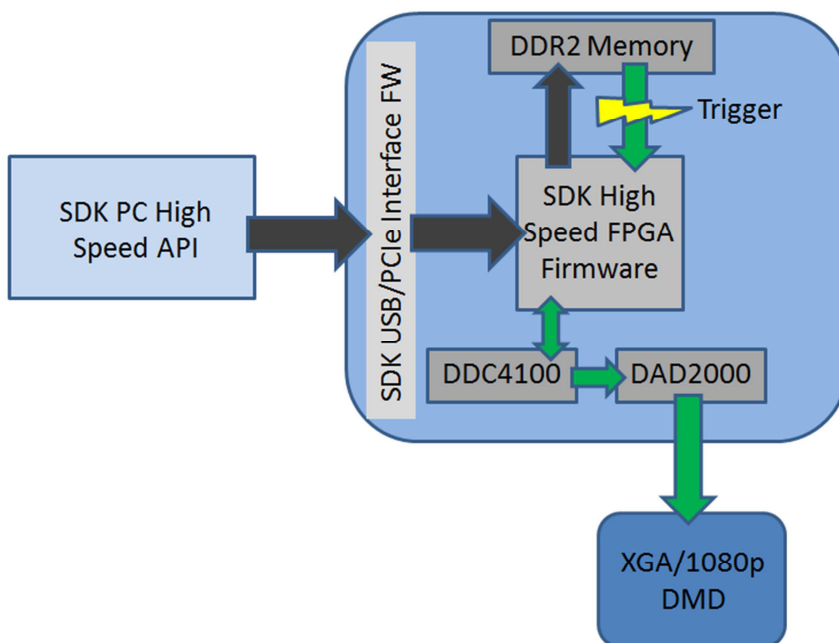

# SDK

## System Highlights

- Economical software controller platform for D4100 and W4100
- Includes FPGA logic, API, and GUI
- High speed operation using global resets
- Compatible with XGA and 1080p DMDs
- Supports up to 8-bit grayscale
- Frame triggers and syncs
- Display custom routines through C++ or LabVIEW
- Future provisions for light source control
- Flexibility for future high speed interface protocols such as PCIe and Serial RapidIO

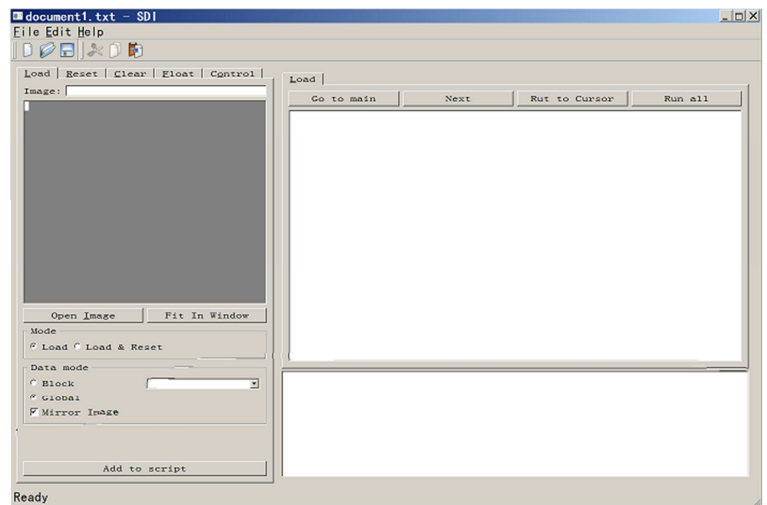

Wintech Digital Systems Technology Corporation is a Texas Instrument's DLP® Authorized Design House with locations in both China and the US. We are a full service engineering company with more than two dozen engineers that can design and manufacture all aspects of DLP® systems including electronics, optics, thermal management, laser light sources, and software.

## Contact Information

2100 E Howell Ave., Ste. 209  
Anaheim, CA 92806  
Tel: +1-949-450-1014  
Fax: +1-949-203-2235  
Email: [info@wintechdigital.com](mailto:info@wintechdigital.com)

Suite A-401, Jiahua Building NO.9  
Shangdi 3 Street Haidian District  
100085, Beijing P.R.China.  
Tel: +86-10-8278-2828  
Fax: +86-10-8278-0028  
Email: [Market@DSPChina.com](mailto:Market@DSPChina.com)