

MHCD Series



MHCD Series provides high current in compact package size with magnetically shielded construction. This power inductor is an excellent power solution for space-limited devices.

Features

- RoHS, Halogen Free and REACH Compliance
- Monolithic, magnetically shielded
- Capable for large current

Applications

- Smartphones, tablets and wearable devices
- HDD, SSD and PC peripheral devices
- DSC, camcoders
- PND
- DC/DC converters

Product Identification

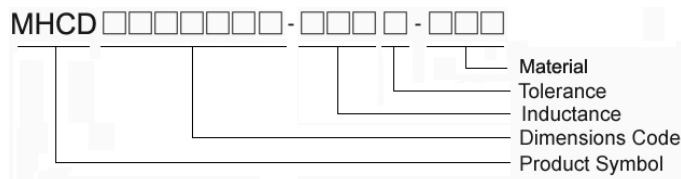

Shape and Dimensions

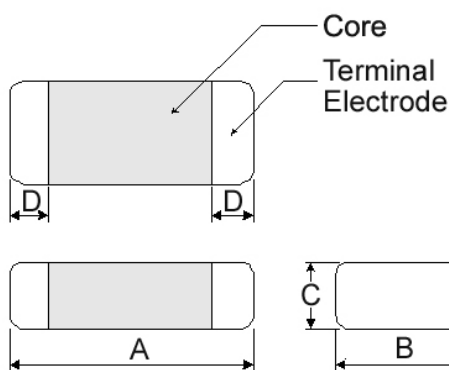

Dimensions in mm

TYPE	A	B	C	D
201210	2.0±0.2	1.25±0.2	1.0Max	0.5±0.3
201610	2.0±0.2	1.6±0.2	1.0Max	0.5±0.3
201612	2.0±0.2	1.6±0.2	1.2Max	0.5±0.3
252010	2.5±0.2	2.0±0.2	1.0Max	0.6±0.3
252012	2.5±0.2	2.0±0.2	1.2Max	0.6±0.3
322510	3.2±0.3	2.5±0.3	1.0Max	0.5±0.3
322512	3.2±0.3	2.5±0.3	1.2Max	0.5±0.3

Recommended Pattern

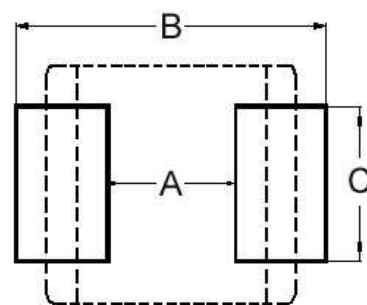

Dimensions in mm

TYPE	A	B	C
201210	0.8~1.2	2.3~2.9	1.0~1.4
201610	0.9	2.0	1.6
201612	0.9	2.0	1.6
252010	1.2	2.8	2.0
252012	1.2	2.8	2.0
322510	1.7	3.2	2.5
322512	1.7	3.2	2.5

Molding Power Choke – MHCD Series

Electrical Characteristics

Part Number	Inductance (μH)	Tolerance ($\pm\%$)	Test Frequency (MHz)	Irms(A)	Isat(A)	RDC($\text{m}\Omega$)
				Max(Typ)	Max(Typ)	Max(Typ)
MHCD201210A-R33M-A8S	0.33	20	2	2.4(3.0)	3.6(4.2)	75(58)
MHCD201210A-R47M-A8S	0.47	20	2	2.2(2.8)	3.2(4.0)	80(61)
MHCD201210A-R68M-A8S	0.68	20	2	2.0(2.5)	3.0(3.6)	105(82)
MHCD201210A-1R0M-A8S	1.0	20	2	1.6(2.0)	2.0(2.6)	155(137)

- **Irms** DC current (A) that will cause an approximate ΔT of 40°C .
- **Isat** DC current (A) that will cause L to drop approximately 30%
- Tolerance : M = $\pm 20\%$
- L : Agilent E4991A/HP4287A+16197A, 2MHz 0.2V
- Rdc : CHEN HWA502
- Isat : Agilent E4980A+HP42841A
- Irms : Agilent 6641 SYSTEM DC POWER SUPPLY
- Operating temperature range from -40°C to 125°C . (Including self - temperature rise)

Test Instruments : E4991A Impedance / Material Analyzer

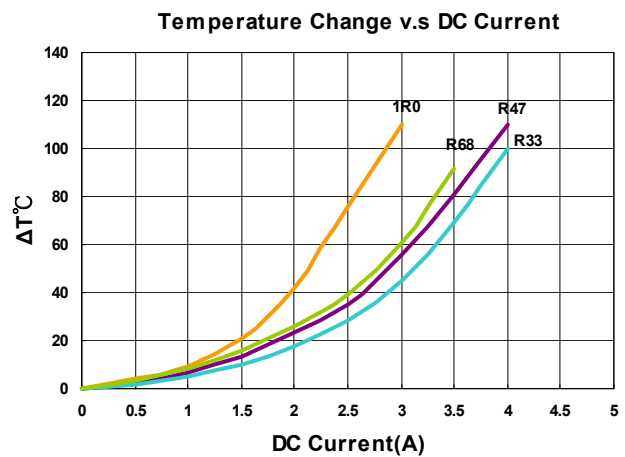
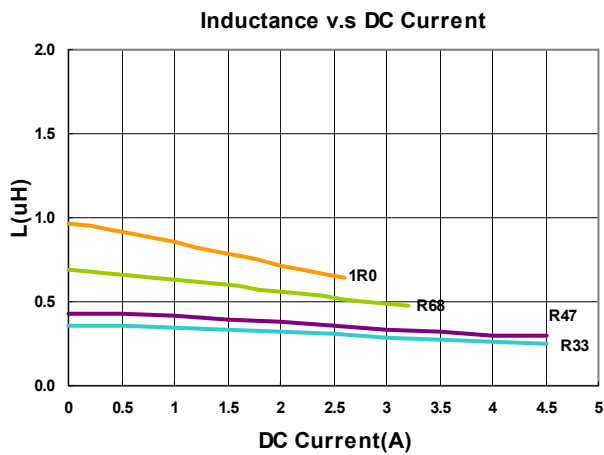

Molding Power Choke – MHCD Series

Electrical Characteristics

Part Number	Inductance (μH)	Tolerance ($\pm\%$)	Test Frequency (MHz)	I _{rms} (A)		I _{sat} (A)		RDC($\text{m}\Omega$)	
				Max(Typ)	Max(Typ)	Max(Typ)	Max(Typ)	Max(Typ)	Max(Typ)
MHCD201610A-R24M-A8S	0.24	20	2	4.0(4.5)	4.2(6.0)	40(28)			
MHCD201610A-R33M-A8S	0.33	20	2	3.5(3.8)	4.0(5.5)	48(40)			
MHCD201610A-R47M-A8S	0.47	20	2	3.0(3.6)	3.2(5.0)	54(44)			
MHCD201610A-R56M-A8S	0.56	20	2	2.8(3.3)	2.8(4.6)	59(46)			
MHCD201610A-R68M-A8S	0.68	20	2	2.4(3.0)	2.7(4.2)	72(55)			
MHCD201610A-1R0M-A8S	1.0	20	2	2.0(2.3)	2.2(3.4)	96(81)			
MHCD201610A-1R5M-A8S	1.5	20	2	1.6(2.0)	2.1(2.8)	150(122)			
MHCD201610A-2R2M-A8S	2.2	20	2	1.3(1.6)	2.0(2.4)	204(170)			

- I_{rms} DC current (A) that will cause an approximate ΔT of 40°C.
- I_{sat} DC current (A) that will cause L to drop approximately 30%
- Tolerance : M = $\pm 20\%$
- L : Agilent E4991/HP4287A+16197A, 2MHz 0.2V
- R_{dc} : CHEN HWA502
- I_{sat} : Agilent E4980A+HP42841A
- I_{rms} : Agilent 6641 SYSTEM DC POWER SUPPLY
- Operating temperature range from -40°C to 125°C. (Including self - temperature rise)

Test Instruments : E4991A Impedance / Material Analyzer

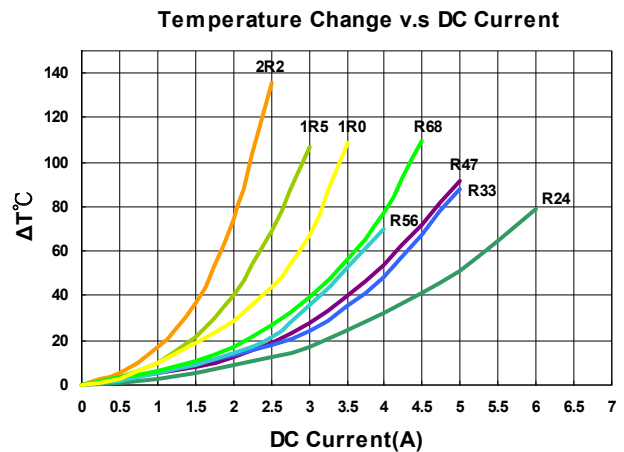
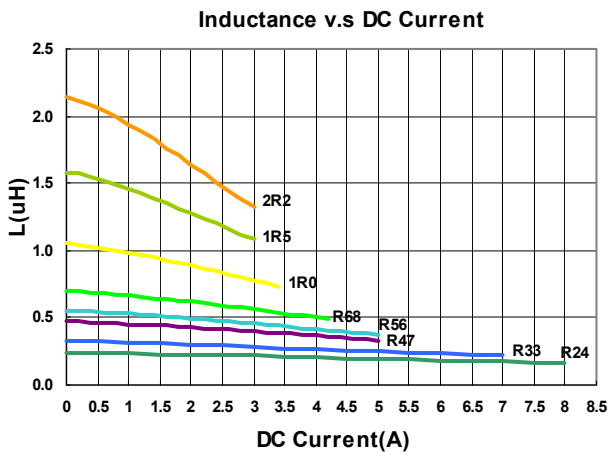

Molding Power Choke – MHCD Series

Electrical Characteristics

Part Number	Inductance (μH)	Tolerance ($\pm\%$)	Test Frequency (MHz)	Irms(A)	Isat(A)	RDC($\text{m}\Omega$)
				Max(Typ)	Max(Typ)	Max(Typ)
MHCD201610B-R24M-A8L	0.24	20	2	3.8(4.4)	5.0(6.0)	30(23)
MHCD201610B-R47M-A8L	0.47	20	2	2.9(3.3)	4.0(4.5)	41(34)
MHCD201610B-R68M-A8L	0.68	20	2	2.5(2.9)	3.3(3.6)	53(44)
MHCD201610B-1R0M-A8L	1.0	20	2	2.2(2.5)	2.8(3.2)	72(60)
MHCD201610B-2R2M-A8L	2.2	20	2	1.5(1.7)	1.8(2.1)	170(142)

- **Irms** DC current (A) that will cause an approximate ΔT of 40°C .
- **Isat** DC current (A) that will cause L to drop approximately 30%
- Tolerance : M = $\pm 20\%$
- L : Agilent E4991/HP4287A+16197A, 2MHz 0.2V
- Rdc : CHEN HWA502
- Isat : Agilent E4980A+HP42841A
- Irms : Agilent 6641 SYSTEM DC POWER SUPPLY
- Operating temperature range from -40°C to 125°C . (Including self - temperature rise)

Test Instruments : E4991A Impedance / Material Analyzer

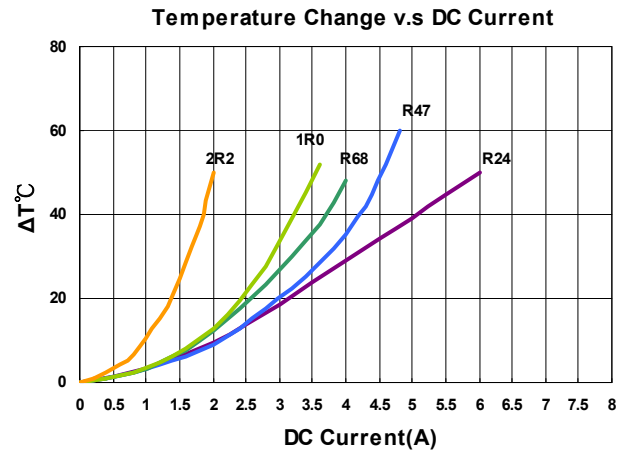
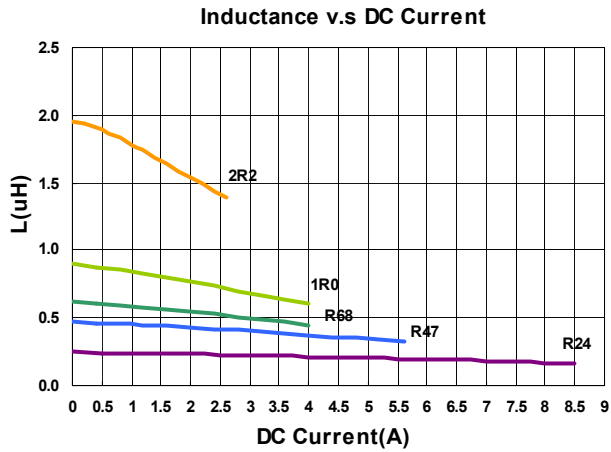

Molding Power Choke – MHCD Series

Electrical Characteristics

Part Number	Inductance (μH)	Tolerance ($\pm\%$)	Test Frequency (MHz)	Irms(A)	Isat(A)	RDC($\text{m}\Omega$)
				Max(Typ)	Max(Typ)	Max(Typ)
MHCD201612A-R24M-A8S	0.24	20	2	4.2(4.8)	5.5(6.5)	35(25)
MHCD201612A-R47M-A8S	0.47	20	2	3.2(3.8)	3.8(5.1)	52(40)
MHCD201612A-R68M-A8S	0.68	20	2	2.6(3.2)	3.3(4.8)	70(53)
MHCD201612A-1R0M-A8S	1.0	20	2	2.3(2.7)	3.1(3.9)	82(67)
MHCD201612A-1R5M-A8S	1.5	20	2	2.2(2.6)	2.6(3.2)	120(95)
MHCD201612A-2R2M-A8S	2.2	20	2	1.3(1.7)	2.0(2.6)	195(165)

- **Irms** DC current (A) that will cause an approximate ΔT of 40°C .
- **Isat** DC current (A) that will cause L to drop approximately 30%
- Tolerance : M = $\pm 20\%$
- L : Agilent E4991A/HP4287A+16197A, 2MHz 0.2V
- Rdc : CHEN HWA502
- Isat : Agilent E4980A+HP42841A
- Irms : Agilent 6641 SYSTEM DC POWER SUPPLY
- Operating temperature range from -40°C to 125°C . (Including self - temperature rise)

Test Instruments : E4991A Impedance / Material Analyzer

Inductance v.s DC Current

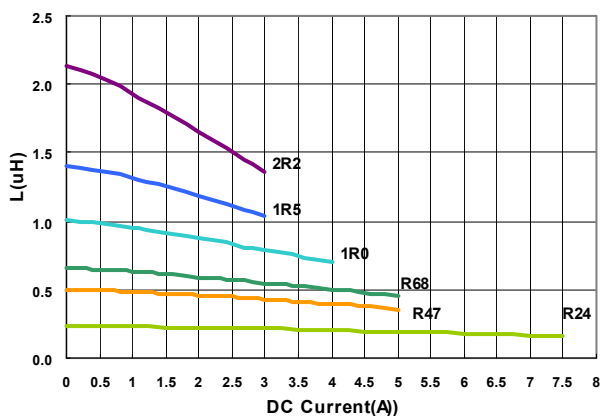

Temperature Change v.s DC Current

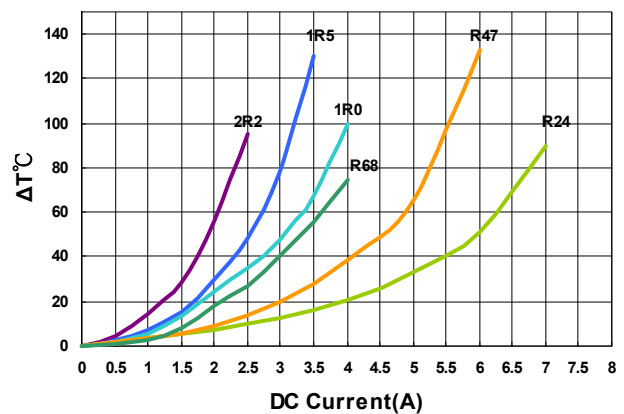

Molding Power Choke – MHCD Series

Electrical Characteristics

Part Number	Inductance (μH)	Tolerance ($\pm\%$)	Test Frequency (MHz)	Irms(A)	Isat(A)	RDC($\text{m}\Omega$)
				Max(Typ)	Max(Typ)	Max(Typ)
MHCD252010A-R24M-A8S	0.24	20	2	4.5(5.0)	7.5(9.5)	40(24)
MHCD252010A-R47M-A8S	0.47	20	2	3.1(3.6)	5.2(6.5)	46(36)
MHCD252010A-R68M-A8S	0.68	20	2	2.9(3.3)	3.8(5.0)	65(49)
MHCD252010A-1R0M-A8S	1.0	20	2	2.5(3.0)	3.4(4.3)	78(60)
MHCD252010A-1R5M-A8S	1.5	20	2	2.2(2.9)	3.2(4.0)	105(82)
MHCD252010A-2R2M-A8S	2.2	20	2	1.4(1.8)	2.6(3.2)	156(130)

- **Irms** DC current (A) that will cause an approximate ΔT of 40°C .
- **Isat** DC current (A) that will cause L to drop approximately 30%
- Tolerance : M = $\pm 20\%$
- L : Agilent E4991A/HP4287A+16197A, 2MHz 0.2V
- Rdc : CHEN HWA502
- Isat : Agilent E4980A+HP42841A
- Irms : Agilent 6641 SYSTEM DC POWER SUPPLY
- Operating temperature range from -40°C to 125°C . (Including self - temperature rise)

Test Instruments : E4991A Impedance / Material Analyzer

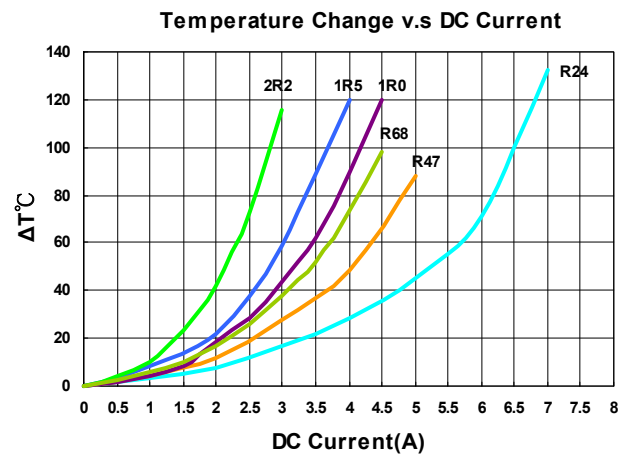
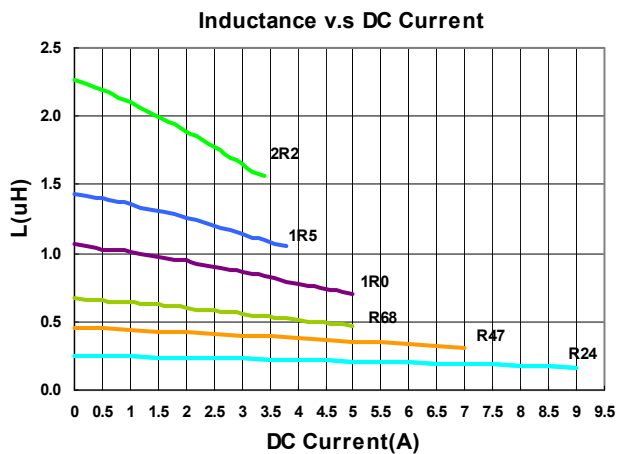

Molding Power Choke – MHCD Series

Electrical Characteristics

Part Number	Inductance (μH)	Tolerance ($\pm\%$)	Test Frequency (MHz)	Irms(A)	Isat(A)	RDC($\text{m}\Omega$)
				Max(Typ)	Max(Typ)	Max(Typ)
MHCD252010B-R33M-A8L	0.33	20	2	3.8(4.4)	5.0(6.0)	31(25)
MHCD252010B-R47M-A8L	0.47	20	2	3.4(3.9)	4.2(4.7)	35(29)
MHCD252010B-1R0M-A8L	1.0	20	2	2.6(3.0)	3.2(3.6)	65(54)
MHCD252010B-1R5M-A8L	1.5	20	2	2.1(2.4)	2.9(3.3)	94(78)
MHCD252010B-2R2M-A8L	2.2	20	2	1.8(2.1)	2.3(2.7)	120(100)
MHCD252010B-4R7M-A8L	4.7	20	2	1.1(1.3)	1.8(2.1)	250(208)

- **Irms** DC current (A) that will cause an approximate ΔT of 40°C .
- **Isat** DC current (A) that will cause L to drop approximately 30%
- Tolerance : M = $\pm 20\%$
- L : Agilent E4991A/HP4287A+16197A, 2MHz 0.2V
- Rdc : CHEN HWA502
- Isat : Agilent E4980A+HP42841A
- Irms : Agilent 6641 SYSTEM DC POWER SUPPLY
- Operating temperature range from -40°C to 125°C . (Including self - temperature rise)

Test Instruments : E4991A Impedance / Material Analyzer

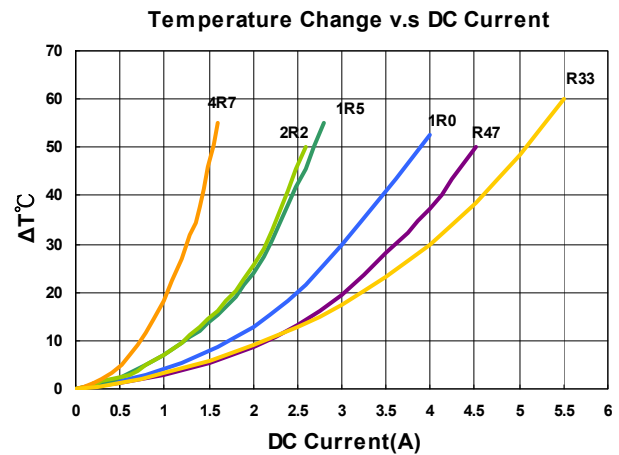
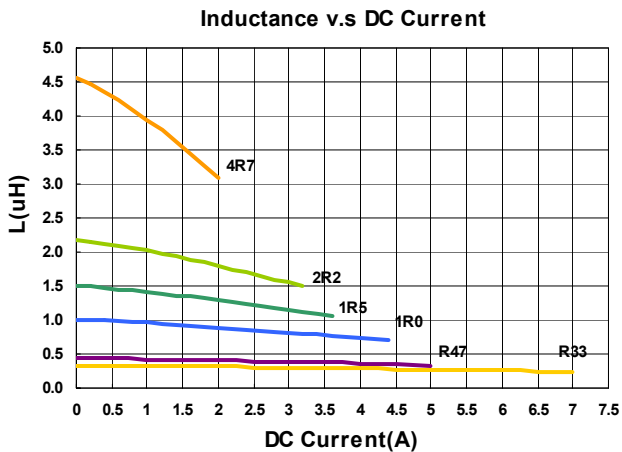

Molding Power Choke – MHCD Series

Electrical Characteristics

Part Number	Inductance (μH)	Tolerance ($\pm\%$)	Test Frequency (MHz)	I _{rms} (A)		I _{sat} (A)		RDC($\text{m}\Omega$)	
				Max(Typ)	Max(Typ)	Max(Typ)	Max(Typ)	Max(Typ)	Max(Typ)
MHCD252012A-R33M-A8S	0.33	20	2	4.0(4.6)	6.8(8.5)	35(27)			
MHCD252012A-R47M-A8S	0.47	20	2	3.7(4.4)	6.2(7.8)	39(29)			
MHCD252012A-R68M-A8S	0.68	20	2	3.3(3.7)	5.5(6.5)	46(40)			
MHCD252012A-1R0M-A8S	1.0	20	2	3.0(3.5)	4.0(5.0)	59(45)			
MHCD252012A-1R5M-A8S	1.5	20	2	2.5(2.7)	3.4(4.0)	70(62)			
MHCD252012A-2R2M-A8S	2.2	20	2	2.0(2.3)	3.3(3.8)	115(102)			
MHCD252012A-3R3M-A8S	3.3	20	2	1.8(2.1)	2.5(2.8)	158(143)			
MHCD252012A-4R7M-A8S	4.7	20	2	1.7(2.1)	2.1(2.7)	240(200)			

- I_{rms} DC current (A) that will cause an approximate ΔT of 40°C.
- I_{sat} DC current (A) that will cause L to drop approximately 30%
- Tolerance : M = $\pm 20\%$
- L : Agilent E4991A/HP4287A+16197A, 2MHz 0.2V
- R_{dc} : CHEN HWA502
- I_{sat} : Agilent E4980A+HP42841A
- I_{rms} : Agilent 6641 SYSTEM DC POWER SUPPLY
- Operating temperature range from -40°C to 125°C. (Including self - temperature rise)

Test Instruments : E4991A Impedance / Material Analyzer

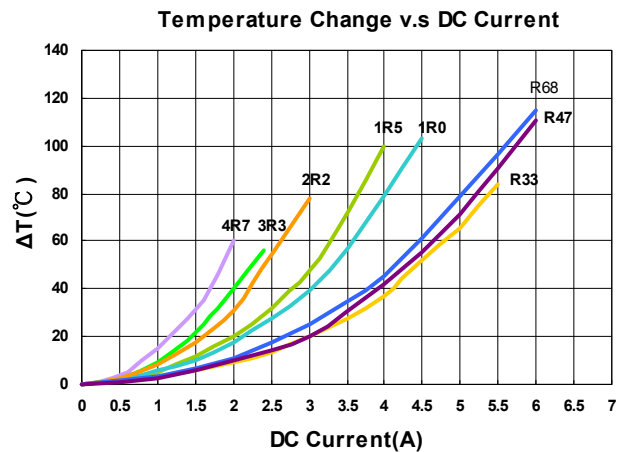
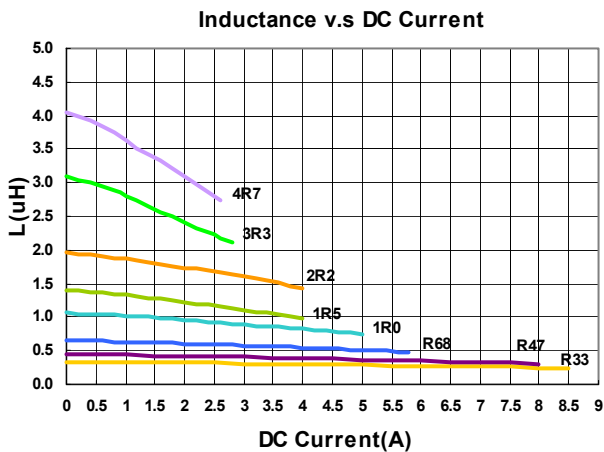

Molding Power Choke – MHCD Series

Electrical Characteristics

Part Number	Inductance (μH)	Tolerance ($\pm\%$)	Test Frequency (MHz)	Irms(A)	Isat(A)	RDC($\text{m}\Omega$)
				Max(Typ)	Max(Typ)	Max(Typ)
MHCD322510A-R47M-A8S	0.47	20	2	3.6(4.2)	5.8(6.6)	37(30)
MHCD322510A-1R0M-A8S	1.0	20	2	3.0(3.3)	4.0(4.6)	56(49)
MHCD322510A-1R5M-A8S	1.5	20	2	2.6(3.0)	3.4(4.0)	75(66)
MHCD322510A-2R2M-A8S	2.2	20	2	2.2(2.5)	2.7(3.2)	108(95)

- **Irms** DC current (A) that will cause an approximate ΔT of 40°C .
- **Isat** DC current (A) that will cause L to drop approximately 30%
- Tolerance : M = $\pm 20\%$
- L : Agilent E4991A/HP4287A+16197A, 2MHz 0.2V
- Rdc : CHEN HWA502
- Isat : Agilent E4980A+HP42841A
- Irms : Agilent 6641 SYSTEM DC POWER SUPPLY
- Operating temperature range from -40°C to 125°C . (Including self - temperature rise)

Test Instruments : E4991A Impedance / Material Analyzer

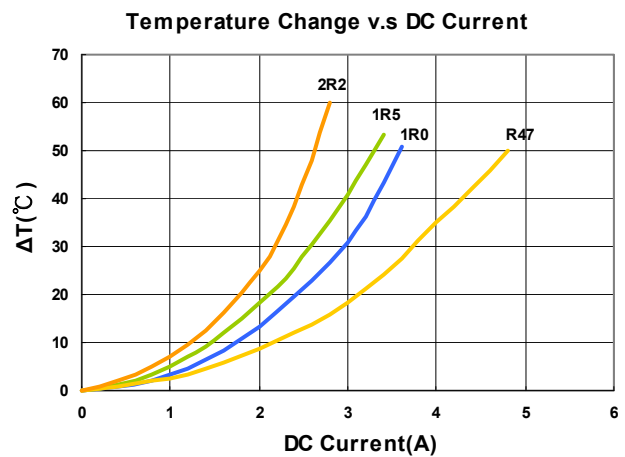
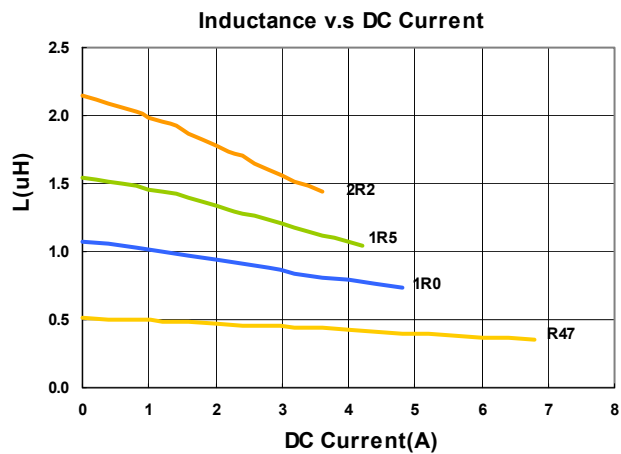

Molding Power Choke – MHCD Series

Electrical Characteristics

Part Number	Inductance	Tolerance	Test Frequency	Irms(A)	Isat(A)	RDC(mΩ)
	(uH)	(±%)	(MHz)	Max(Typ)	Max(Typ)	Max(Typ)
MHCD322512A-R47M-A8S	0.47	20	2	5.0(5.8)	8.0(9.0)	27(21)
MHCD322512A-1R0M-A8S	1.0	20	2	3.8(4.2)	5.8(6.3)	42(34)
MHCD322512A-1R5M-A8S	1.5	20	2	2.8(3.2)	4.0(4.5)	68(58)
MHCD322512A-2R2M-A8S	2.2	20	2	2.4(2.7)	3.6(4.0)	85(75)

- **Irms** DC current (A) that will cause an approximate ΔT of 40°C.
- **Isat** DC current (A) that will cause L to drop approximately 30%
- Tolerance : M = ±20%
- L : Agilent E4991A/HP4287A+16197A, 2MHz 0.2V
- Rdc : CHEN HWA502
- Isat : Agilent E4980A+HP42841A
- Irms : Agilent 6641 SYSTEM DC POWER SUPPLY
- Operating temperature range from -40°C to 125°C. (Including self - temperature rise)

Test Instruments : E4991A Impedance / Material Analyzer

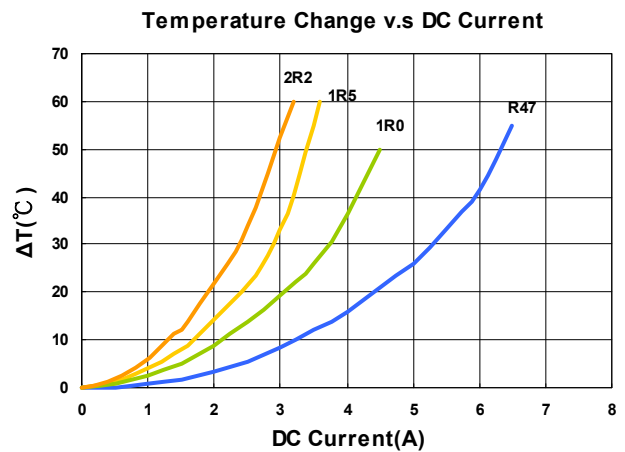
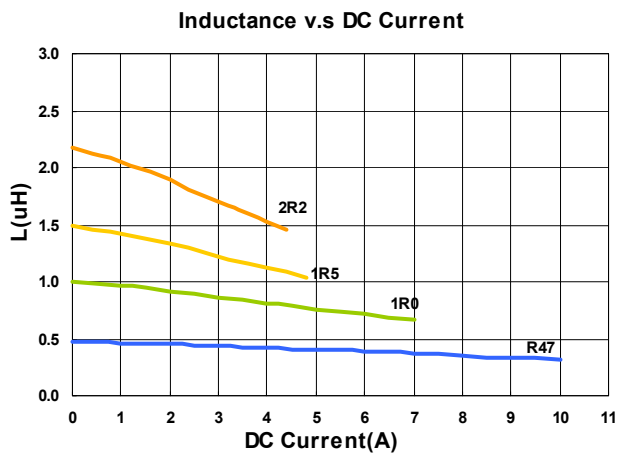

Molding Power Choke – MHCD Series

Packaging Specifications

Tape Dimensions

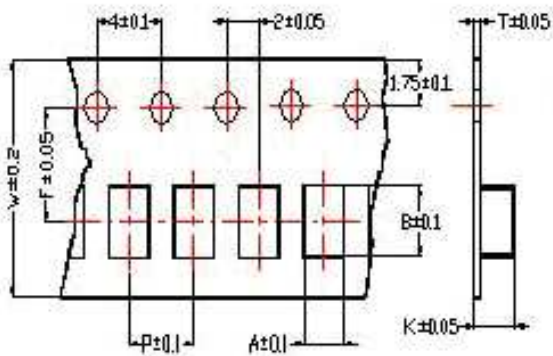

Tape Material

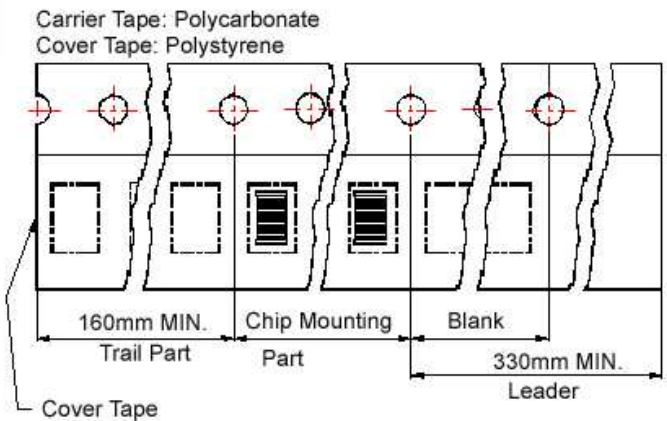

Reel Dimensions

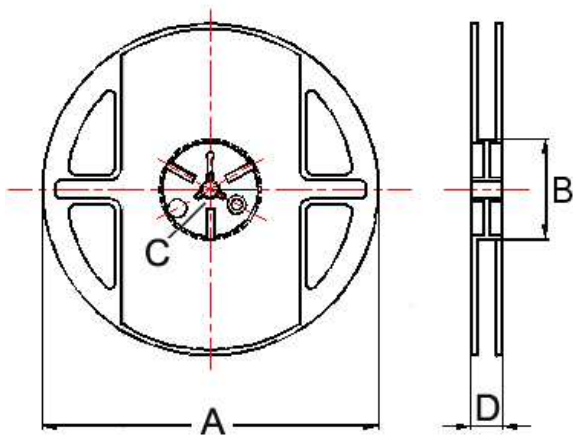

Dimensions in mm

TYPE	Tape Dimensions							Reel Dimensions				Quantity PCS / REEL
	A	B	T	W	P	F	K	A	B	C	D	
201210	1.45	2.25	0.22	8	4	3.5	1.04	178	60	12	1.5	3000
201610	1.80	2.20	0.22	8	4	3.5	1.15	178	60	12	1.5	3000
201612	1.80	2.20	0.22	8	4	3.5	1.35	178	60	12	1.5	3000
252010	2.25	2.80	0.22	8	4	3.5	1.15	178	60	12	1.5	3000
252012	2.25	2.80	0.22	8	4	3.5	1.35	178	60	12	1.5	3000
322510	2.80	3.55	0.23	8	4	3.5	1.20	178	60	12	1.5	3000
322512	2.80	3.50	0.23	8	4	3.5	1.34	178	60	12	1.5	3000