

## SPECIFICATION FOR APPROVAL

CUSTOMER : \_\_\_\_\_

CUSTOMER P. N. : \_\_\_\_\_

PRODUCT MODEL : \_\_\_\_\_ JAEU-C-040S105DS \_\_\_\_\_

PRODUCT NO. : \_\_\_\_\_

SAMPLE DATE : \_\_\_\_\_

| CUSTOMER AUTHORIZED SIGNATURE |  |  |
|-------------------------------|--|--|
|                               |  |  |

Please return to us one copy of "SPECIFICATION FOR APPROVAL" with you approved signature.

ADD: Jaro Components, Inc. 6600 Park of Commerce Blvd.  
Boca Raton, FL 33487

TEL: 561-241-6700

FAX: 561-241-3328

<http://www.jarocomponents.com>

|              |             |              |
|--------------|-------------|--------------|
| Prepared By: | Checked By: | Approved By: |
|              |             |              |



Table Of Content

|  |    |
|--|----|
| 1. Scope.....  | 4  |
| 2. Input Characteristics.....                                  | 4  |
| 2.1. Input Voltage & Frequency .....                           | 4  |
| 2.2. Input AC Current .....                                    | 4  |
| 2.3. Inrush Current (cold start) .....                         | 4  |
| 2.4. Power Factor .....  | 4  |
| 2.5. Efficiency .....  | 4  |
| 3. Output Characteristics.....                                 | 4  |
| 3.1. Static Output Characteristics <Vo & R&N<5000mVp-p > ..... | 4  |
| 3.2. Voltage/Current Curve .....                               | 5  |
| 3.3. Turn - on Delay Time .....                                | 5  |
| 4. Protection Requirements.....                                | 5  |
| 4.1. Short Circuit Protection .....                            | 5  |
| 4.2. Over Voltage Protection .....                             | 5  |
| 5. Environment Requirements.....                               | 5  |
| 5.1. Operating Temperature and Relative Humidity .....         | 5  |
| 5.2. Storage Temperature and Relative Humidity .....           | 5  |
| 5.3. Vibration .....   | 5  |
| 6. Reliability Requirements.....                               | 5  |
| 6.1. Life Time Qualification .....                             | 5  |
| 6.2. MTBF Qualification .....                                  | 5  |
| 7. Safety & EMI/EMS Standards.....                             | 6  |
| 7.1. Safety Category .....                                     | 6  |
| 7.2. EMI Standards .....                                       | 6  |
| 7.3. EMS Standards .....                                       | 6  |
| 7.4. Energy Star Standards .....                               | 6  |
| 8. Main Safety Test Items.....                                 | 7  |
| 8.1. Dielectric Strength(Hi-pot) .....                         | 7  |
| 8.2. Leakage Current .....                                     | 7  |
| 8.3. Insulation Resistance .....                               | 7  |
| 9. Derating Curve.....   | 7  |
| 10. Dimming Explain.....                                       | 8  |
| 10.1. Dimming sketch map shown as following .....              | 8  |
| 10.2. Dimming Voltage/Current Proportion Curve: .....          | 8  |
| 11. Mach. Outline Drawing.....                                 | 9  |
| 12. I/O Marking Drawing.....                                   | 10 |

## 1. Scope

The document detail the electrical, mechanical and environmental specifications of a 40W constant current LED driver. The LED driver shall meet the RoHS requirement.

Description:

- LED driver (With AL Case)                       LED driver (With Plastic Case)  
 Open Frame     Others

## 2. Input Characteristics

### 2.1. Input Voltage & Frequency

The range of input voltage is from 90 to 305Vac single phase.

| Items           | Minimum | Nominal    | Maximum |
|-----------------|---------|------------|---------|
| Input Voltage   | 90Vac   | 100-277Vac | 305Vac  |
| Input Frequency | 47Hz    | 60Hz/50Hz  | 63Hz    |

### 2.2. Input AC Current

0.48Amax. @ 100-277Vac input & full load.

### 2.3. Inrush Current (cold start)

65Amax. @ 230Vac input, 25°C.

### 2.4. Power Factor

Typical value is 0.95@110Vac input &100% load;

Typical value is 0.90@220Vac input &100% load.

### 2.5. Efficiency

Typical value is 84% @110Vac input & full load;

Typical value is 84% @220Vac input & full load.

## 3. Output Characteristics

### 3.1. Static Output Characteristics <Vo & R<sub>N</sub><5000mVp-p >

Ripple & Noise: Measurement is done by 20MHz bandwidth oscilloscope and the output paralleled a 0.1uF ceramic capacitor and a 10uF electrolysis capacitor.

(test under the condition of rated input and rated output)

### 3.2. Voltage/Current Curve

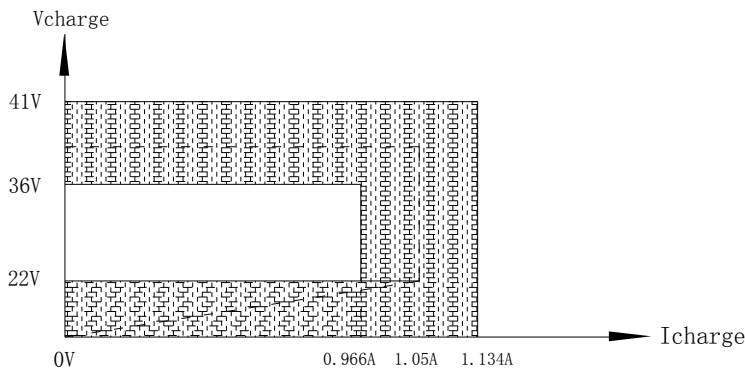

| Constant Current Output Characteristics | Min.   | Typ.  | Max.   |
|---|--------|-------|--------|
| Output Current Range                    | 0.966A | 1.05A | 1.134A |
| Output Voltage Range                    | 22V    | /     | 36V    |

### 3.3. Turn - on Delay Time

1.0S typical @ 100-277Vac input & full load.

## 4. Protection Requirements

### 4.1. Short Circuit Protection

The input power shall decrease when the output rail short, the power supply shall no damage, and shall be self-recovery when the fault condition is removed.

### 4.2. Over Voltage Protection

When the output voltage is over (1.2-1.4)  $V_{out}$ , the product will shutdown and enter protection status, the driver will re-start and work normally if the fault condition was eliminated.

## 5. Environment Requirements

### 5.1. Operating Temperature and Relative Humidity

-25°C to +50°C;  
5%RH to 95%RH.

### 5.2. Storage Temperature and Relative Humidity

-35°C to +70°C;  
5% to 95%RH non-condensing at Sea level shall be low 10,000 feet.

### 5.3. Vibration

10 to 300Hz sweep at a constant acceleration of 1.0G (Breadth: 3.5mm) for 1Hour for each of the perpendicular axes X, Y, Z.

## 6. Reliability Requirements

### 6.1. Life Time Qualification

The life time shall be at least 3 years at 110Vac input, 80% load and 45°C ambient temperature.

### 6.2. MTBF Qualification

The MTBF shall be at least 490,000 hours at 110Vac, 80% load and 25°C ambient temperature (MIL-HDBK-217F).

### 7. Safety & EMI/EMS Standards

#### 7.1. Safety Category

| Safety Category | Country      | Standard   |
|-----------------|--------------|--|
| CUL             | USA & Canada | UL8750, UL935, UL1012, UL1310 Class 2, CSA-C22. 2 No. 107. 1, CSA C22. 2 No. 223-M91 Class 2 |
| CE              | Europe       | EN 61347-1, EN 61347-2-13  |

#### 7.2. EMI Standards

| EMI Standards | Country | Notes   |
|---------------|---------|---|
| EN 55015      | Europe  | Conducted emission Test & Radiated emission Test with 6 dB margin |
| FCC           | USA     | FCC Part 15 class B, ANSI C63. 4:2009                             |

#### 7.3. EMS Standards

|               |  |
|---------------|--|
| EN 61000-3-2  | Harmonic current emissions   |
| EN 61000-3-3  | Voltage fluctuations & flicker   |
| EN 61000-4-2  | Electrostatic Discharge(ESD): 8kV air discharge, 4kV contact discharge |
| EN 61000-4-3  | Radio-Frequency Electromagnetic Field Susceptibility Test-RS           |
| EN 61000-4-4  | Electrical Fast Transient / Burst-EFT                                  |
| EN 61000-4-5  | Surge Immunity Test: AC Power Line: line to line 1 kV                  |
| EN 61000-4-6  | Conducted Radio Frequency Disturbances Test-CS                         |
| EN 61000-4-8  | Power Frequency Magnetic Field Test                                    |
| EN 61000-4-11 | Voltage Dips   |
| EN 61547      | Electromagnetic Immunity Requirements Applies To Lighting Equipment    |

#### 7.4. Energy Star Standards

| Energy Star Standards    | Notes  |
|--------------------------|--|
| ANSI / IEEE C62. 41-1991 | Transient protection, power supply shall comply with Class A operation. The line transient shall consist of seven strikes of a 100kHz ring wave, 2.5kV level, for both common mode and differential mode |

8. Main Safety Test Items

8.1. Dielectric Strength (Hi-pot)

Primary to Secondary: 3750Vac 10mA Max / 60second (3second for production) / Finished goods

8.2. Leakage Current

0.5mA max. at 230Vac/50Hz input.

8.3. Insulation Resistance

The IR shall be at least 50MΩ when apply 500Vdc between primary and secondary.

9. Derating Curve

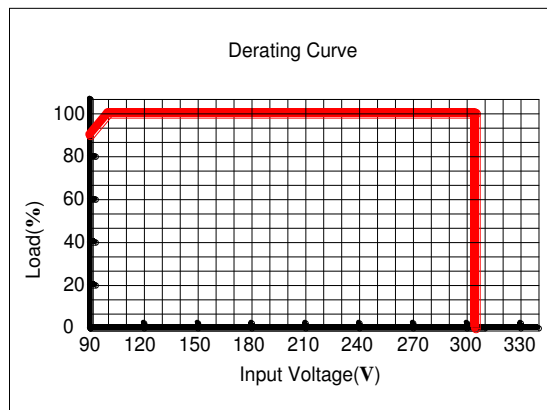
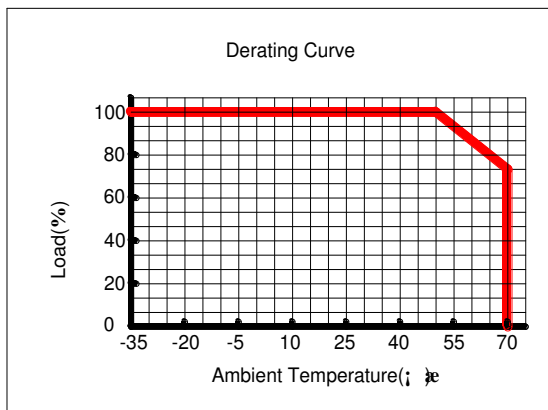

10. Dimming Explain

10.1. Dimming sketch map shown as following

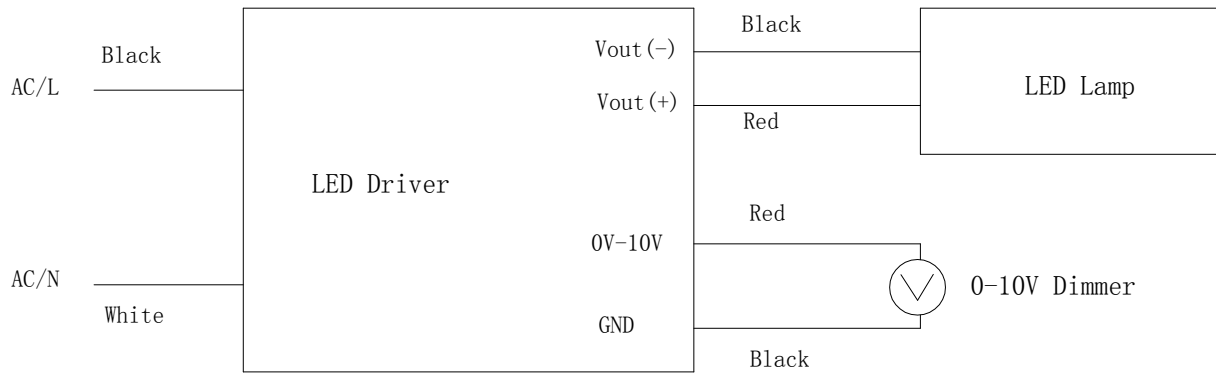

Notes:

1. A 0-10V dimmer connected to DIM Port for achieving 20-100% brightness dimming by changing the voltage(0-10V) of IsenPse .
2. One LED driver, one brightness controller control one LED lamp only.

10.2. Dimming Voltage/Current Proportion Curve:

|                     |       |       |       |       |       |       |       |       |       |       |     |
|---------------------|-------|-------|-------|-------|-------|-------|-------|-------|-------|-------|-----|
| Dimming Voltage (V) | 0     | 1     | 2     | 3     | 4     | 5     | 6     | 7     | 8     | 9     | 10  |
| Dimming Current (A) | 0.195 | 0.286 | 0.377 | 0.468 | 0.558 | 0.647 | 0.738 | 0.827 | 0.915 | 1.002 | 1.1 |

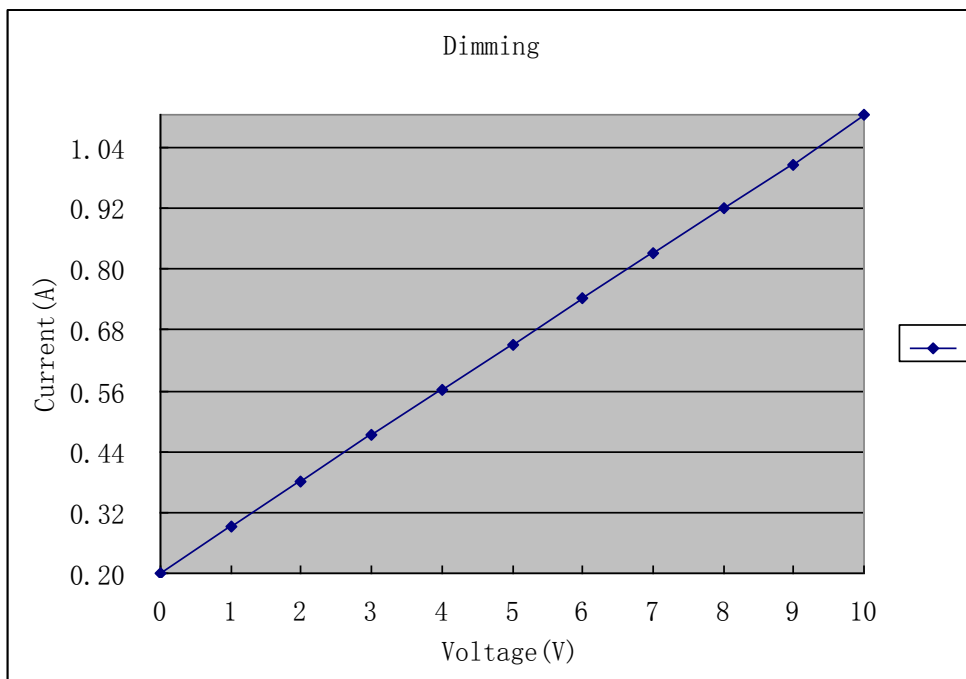

11. Mach. Outline Drawing

1. Tolerance: unmarked tolerance all is  $\pm 0.5$ , marked according to tolerance of it
2. Unit/单位: mm

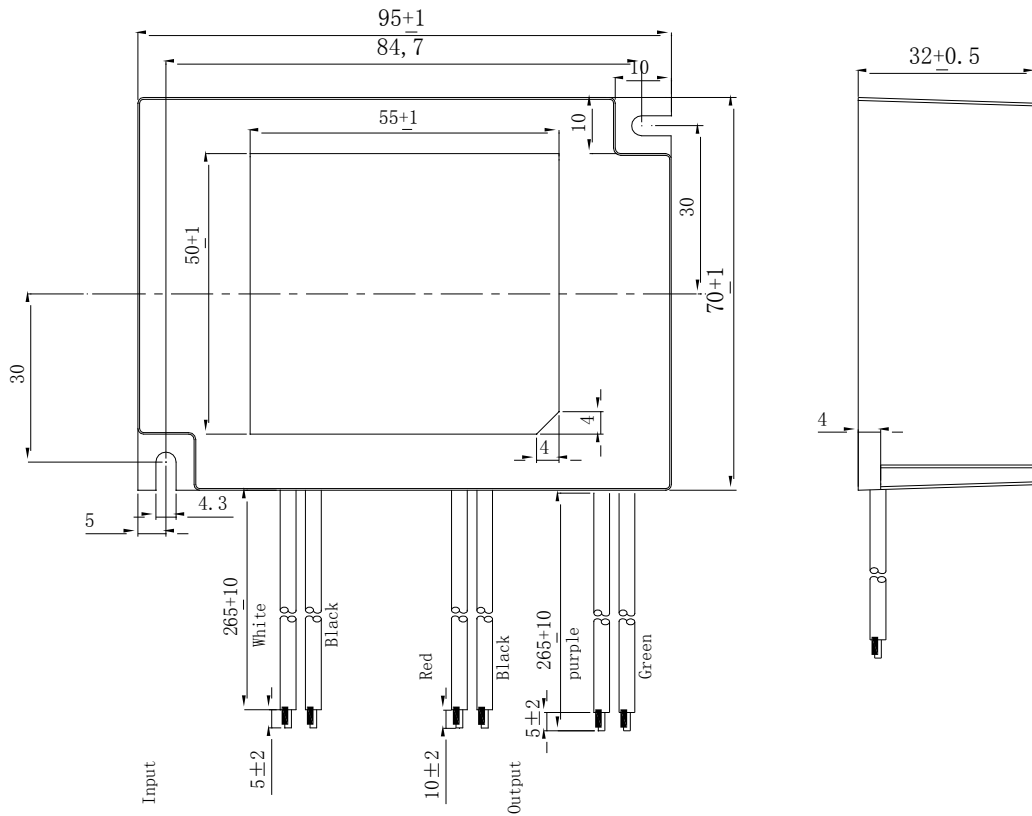

| Dimensions | Millimeters (Inches) |
|------------|----------------------|
| Length     | 95 (3.74)            |
| Width      | 70 (2.76)            |
| Height     | 32 (1.26)            |

| Wire         | Specification |
|--------------|---------------|
| AC Input/输入  | UL1672 18AWG  |
| DC Output/输出 | UL1015 18AWG  |
| Dimming/调光   | UL1569 22AWG  |

12. I/O Marking Drawing

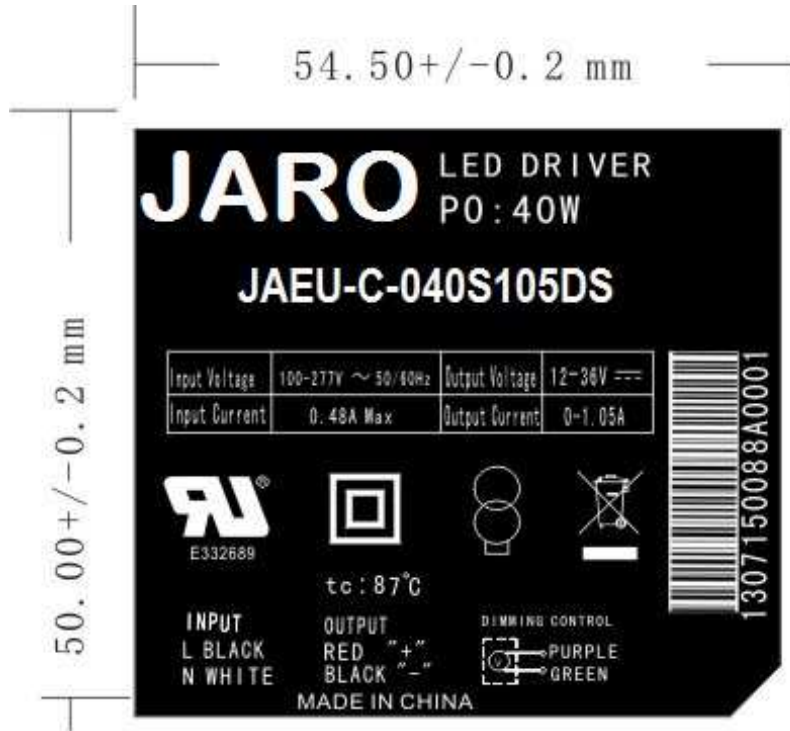

13 0715 0088 A 0001

Y M D CODE LINE NO.

Bar code for 128 formate,  
Date of production need to be updated

Remark:

1. Material: PET 120#;
2. White words with black background+lightfoils;
3. RoHS;
4. "回" height ≥ 5mm;
5. "WEEE" height ≥ 7mm