

# PCK351

1 : 10 clock distribution device with 3-state outputs

Rev. 02 — 16 December 2005

Product data sheet

## 1. General description

---

The PCK351 is a high-performance 3.3 V LVTTTL clock distribution device. The PCK351 enables a single clock input to be distributed to ten outputs with minimum output skew and pulse skew. The use of distributed  $V_{CC}$  and GND pins in the PCK351 ensures reduced switching noise.

The PCK351 is characterized for operation over the supply range 3.0 V to 3.6 V, and over the industrial temperature range  $-40\text{ }^{\circ}\text{C}$  to  $+85\text{ }^{\circ}\text{C}$ .

## 2. Features

---

- 1 : 10 LVTTTL clock distribution
- Low output-to-output skew
- Low output pulse skew
- Overvoltage tolerant inputs and outputs
- LVTTTL-compatible inputs and outputs
- Distributed  $V_{CC}$  and ground pins reduce switching noise
- Balanced high-drive outputs ( $-32\text{ mA } I_{OH}$ ,  $32\text{ mA } I_{OL}$ )
- Reduced power dissipation due to the state-of-the-art QUBiC-LP process
- Supply range of +3.0 V to +3.6 V
- Package options include plastic small-outline (D) and shrink small-outline (DB) packages
- Industrial temperature range  $-40\text{ }^{\circ}\text{C}$  to  $+85\text{ }^{\circ}\text{C}$

### 3. Quick reference data

**Table 1: Quick reference data**

$GND = 0\text{ V}$ ;  $T_{amb} = 25\text{ °C}$ ;  $t_r = t_f \leq 3.0\text{ ns}$ .

Symbol	Parameter	Conditions	Min	Typ	Max	Unit
$t_{PLH}$	LOW-to-HIGH propagation delay	A input to Yn outputs; $C_L = 50\text{ pF}$ ; $V_{CC} = 3.3\text{ V}$	3.1	3.6	4.1	ns
$t_{PHL}$	HIGH-to-LOW propagation delay	A input to Yn outputs; $C_L = 50\text{ pF}$ ; $V_{CC} = 3.3\text{ V}$	3.1	3.6	4.1	ns
$C_i$	input capacitance	$V_{CC} = 3.3\text{ V}$ ; $V_I = V_{CC}$ or GND; $f = 10\text{ MHz}$	-	4	-	pF
$C_o$	output capacitance	$V_{CC} = 3.3\text{ V}$ ; $V_O = V_{CC}$ or GND; $f = 10\text{ MHz}$	-	6	-	pF
$C_{PD}$	power dissipation capacitance [1]	$C_L = 50\text{ pF}$ ; $f = 1\text{ MHz}$	-	48	-	pF

[1]  $C_{PD}$  is used to determine the dynamic power dissipation (P in  $\mu\text{W}$ ).

$P = C_{PD} \times V_{CC}^2 \times f_i + \sum (C_L \times V_{CC}^2 \times f_o)$  where:

$f_i$  = input frequency in MHz;

$f_o$  = output frequency in MHz;

$\sum (C_L \times V_{CC}^2 \times f_o)$  = sum of outputs;

$C_L$  = output load capacitance in pF;

$V_{CC}$  = supply voltage in volts.

### 4. Ordering information

**Table 2: Ordering information**

$T_{amb} = -40\text{ °C}$  to  $+85\text{ °C}$

Type number	Package		Version
	Name	Description	
PCK351D	SO24	plastic small outline package; 24 leads; body width 7.5 mm	SOT137-1
PCK351DB	SSOP24	plastic shrink small outline package; 24 leads; body width 5.3 mm	SOT340-1

5. Functional diagram

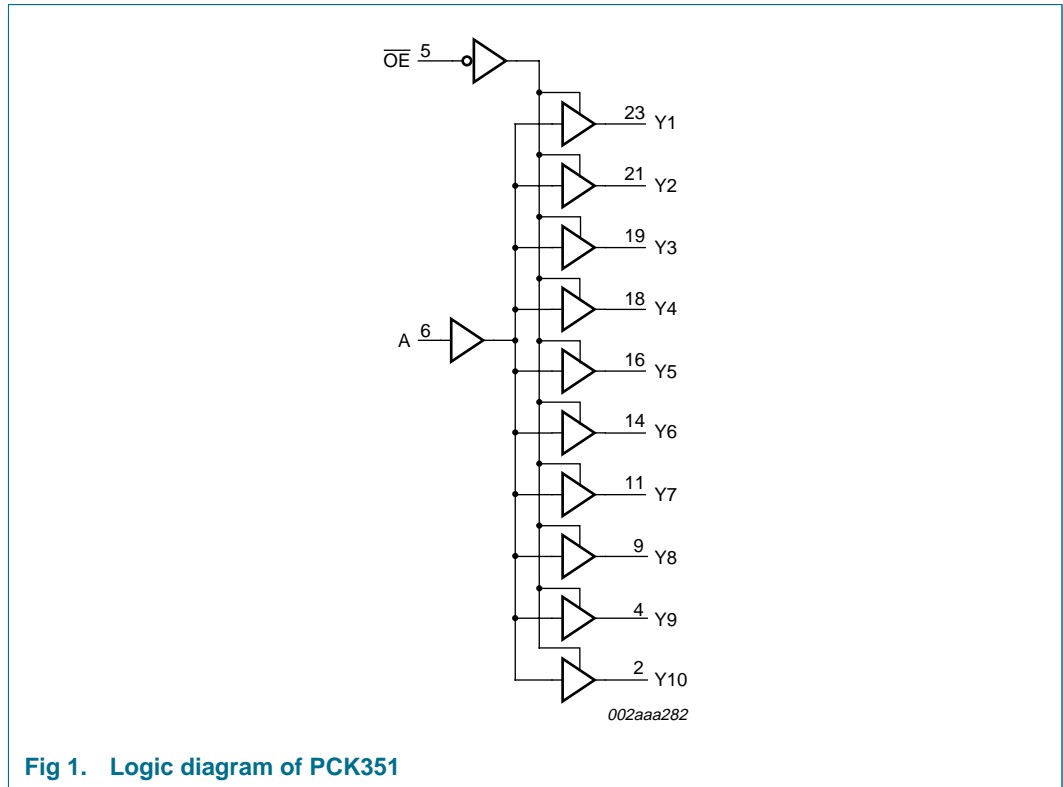

Fig 1. Logic diagram of PCK351

## 6. Pinning information

### 6.1 Pinning

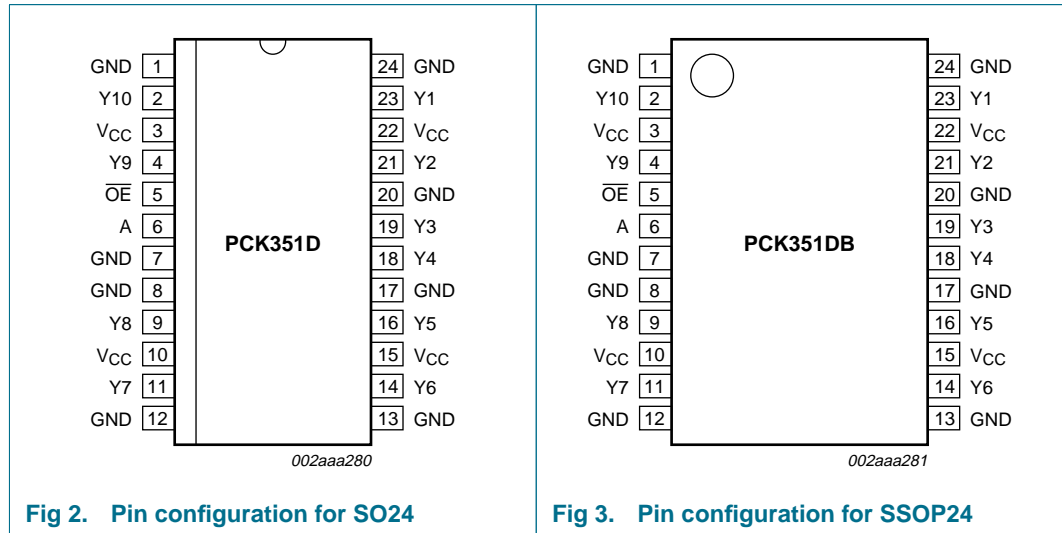

Fig 2. Pin configuration for SO24

Fig 3. Pin configuration for SSOP24

### 6.2 Pin description

Table 3: Pin description

Symbol	Pin	Description
GND	1, 7, 8, 12, 13, 17, 20, 24	ground (0 V)
Y10	2	outputs
Y9	4	
Y8	9	
Y7	11	
Y6	14	
Y5	16	
Y4	18	
Y3	19	
Y2	21	
Y1	23	
V <sub>CC</sub>	3, 10, 15, 22	supply voltage
OE	5	output enable input (active LOW)
A	6	data input

## 7. Functional description

Refer to [Figure 1 “Logic diagram of PCK351”](#).

### 7.1 Function table

**Table 4: Function table**

*H = HIGH voltage level; L = LOW voltage level; Z = high-impedance OFF-state*

Inputs		Outputs
A	$\overline{OE}$	Yn
L	H	Z
H	H	Z
L	L	L
H	L	H

### 7.2 Logic symbol

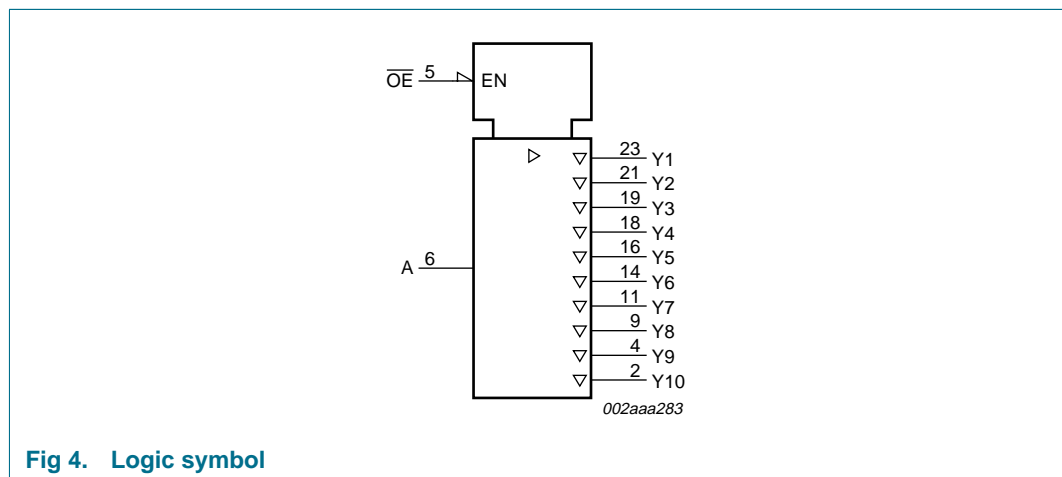

**Fig 4. Logic symbol**

## 8. Limiting values

**Table 5: Limiting values**

In accordance with the Absolute Maximum Rating System (IEC 60134). [\[1\]](#)

Symbol	Parameter	Conditions	Min	Max	Unit
$V_{CC}$	supply voltage		-0.5	+4.6	V
$V_I$	input voltage		-0.5 <a href="#">[2]</a>	+7.0	V
$V_O$	output voltage		-0.5 <a href="#">[2]</a>	+3.6	V
$I_{IK}$	input clamping current	$V_I < 0$ V	-	-18	mA
$I_{OK}$	output clamping current	$V_I < 0$ V	-	-50	mA
$I_{O(sink)}$	output sink current		-	64	mA
$I_{CC}$	quiescent supply current		-	$\pm 75$	mA
$I_{GND}$	ground current		-	$\pm 75$	mA
$T_{stg}$	storage temperature		-65	+150	$^{\circ}\text{C}$
P	power dissipation	$T_{amb} = +55$ $^{\circ}\text{C}$			
		SO package	-	0.65	W
		SSOP package	-	1.7	W

- [1] The performance capability of a high-performance integrated circuit in conjunction with its thermal environment can create junction temperatures which are detrimental to reliability. The maximum junction temperature of this integrated circuit should not exceed 150  $^{\circ}\text{C}$ .
- [2] The input and output negative voltage ratings may be exceeded if the input and output clamping currents are observed.

## 9. Recommended operating conditions

**Table 6: Recommended operating conditions**

Unused pins (input or I/O) must be held HIGH or LOW.

Symbol	Parameter	Conditions	Min	Max	Unit
$V_{CC}$	supply voltage		3.0	3.6	V
$V_{IH}$	HIGH-state input voltage		2.0	5.5	V
$V_I$	input voltage		0	0.8	V
$T_{amb}$	ambient temperature	see <a href="#">Table 7</a> and <a href="#">Table 8</a> per device	-40	+85	$^{\circ}\text{C}$
$t_r$	rise time	input; $V_{CC} = 3.3 \pm 0.3$ V	-	100	ns/V
$t_f$	fall time	input; $V_{CC} = 3.3 \pm 0.3$ V	-	100	ns/V

## 10. Characteristics

**Table 7: Static characteristics**

Over recommended operating conditions; voltages are referenced to GND (ground = 0 V).  $T_{amb} = 25\text{ }^{\circ}\text{C}$ .

Symbol	Parameter	Conditions	Min	Typ	Max	Unit
$V_{IK}$	input clamping voltage	$V_{CC} = 3.0\text{ V}$ ; $I_I = -18\text{ mA}$	-	-	-1.2	V
$V_{OH}$	HIGH-state output voltage	$V_{CC} = 3.0\text{ V}$ ; $I_{OH} = -32\text{ mA}$	2.0	-	-	V
$V_{OL}$	LOW-state output voltage	$V_{CC} = 3.0\text{ V}$ ; $I_{OL} = 32\text{ mA}$	-	-	0.5	V
$I_{LI}$	input leakage current	$V_{CC} = 3.6\text{ V}$ ; $V_I = \text{GND or } 5.5\text{ V}$	-	-	$\pm 1.0$	$\mu\text{A}$
$I_{LO}$	output leakage current	$V_{CC} = 3.6\text{ V}$ ; $V_O = 2.5\text{ V}$	-15	-	-150	mA
$I_{OZ}$	OFF-state output current	3-state; $V_{CC} = 3.6\text{ V}$ ; $V_O = 3\text{ V}$	[1]	-	$\pm 10$	$\mu\text{A}$
$I_{CC}$	quiescent supply current	$V_{CC} = 3.6\text{ V}$ ; $V_I = V_{CC}$ or GND; $I_O = 0\text{ A}$				
		outputs HIGH	-	-	0.3	mA
		outputs LOW	-	-	25	mA
	outputs disabled	-	-	0.3	mA	
$C_i$	input capacitance	$V_{CC} = 3.3\text{ V}$ ; $V_I = V_{CC}$ or GND; $f = 10\text{ MHz}$	-	4	-	pF
$C_o$	output capacitance	$V_{CC} = 3.3\text{ V}$ ; $V_O = V_{CC}$ or GND; $f = 10\text{ MHz}$	-	6	-	pF

[1] Not more than one output should be tested at a time, and the duration of the test should not exceed one second.

**Table 8: Dynamic characteristics** $GND = 0\text{ V}$ ;  $t_r = t_f \leq 2.5\text{ ns}$ .

Symbol	Parameter	Conditions	Min	Typ	Max	Unit
<b><math>V_{CC} = 3.3\text{ V}</math>; <math>T_{amb} = 25\text{ °C}</math>; <math>C_L = 50\text{ pF}</math></b>						
$t_{PLH}$	LOW-to-HIGH propagation delay	A to Yn; see <a href="#">Figure 5</a> and <a href="#">Figure 8</a>	3.1	3.8	4.1	ns
$t_{PHL}$	HIGH-to-LOW propagation delay	A to Yn; see <a href="#">Figure 5</a> and <a href="#">Figure 8</a>	3.1	3.8	4.1	ns
$t_{PZH}$	OFF-state to HIGH propagation delay	$\overline{OE}$ to Yn; see <a href="#">Figure 6</a> and <a href="#">Figure 8</a>	1.8	3.8	5.5	ns
$t_{PZL}$	OFF-state to LOW propagation delay	$\overline{OE}$ to Yn; see <a href="#">Figure 6</a> and <a href="#">Figure 8</a>	1.8	3.8	5.5	ns
$t_{PHZ}$	HIGH to OFF-state propagation delay	$\overline{OE}$ to Yn; see <a href="#">Figure 6</a> and <a href="#">Figure 8</a>	1.8	3.8	5.9	ns
$t_{PLZ}$	LOW to OFF-state propagation delay	$\overline{OE}$ to Yn; see <a href="#">Figure 6</a> and <a href="#">Figure 8</a>	1.8	3.8	5.9	ns
$t_{sk(o)}$	output skew time	A to Yn; output-to-output; see <a href="#">Figure 7</a> and <a href="#">Figure 8</a>	-	0.3	0.5	ns
$t_{sk(p)}$	pulse skew time	A to Yn; see <a href="#">Figure 7</a> and <a href="#">Figure 8</a>	-	0.2	0.8	ns
$t_{sk(pr)}$	process skew time	A to Yn; part-to-part; see <a href="#">Figure 7</a> and <a href="#">Figure 8</a>	-	-	1	ns
$t_r$	rise time	A to Yn; see <a href="#">Figure 5</a> and <a href="#">Figure 8</a>	0.3	-	2.0	ns
$t_f$	fall time	A to Yn; see <a href="#">Figure 5</a> and <a href="#">Figure 8</a>	0.3	-	2.0	ns
<b><math>V_{CC} = 3.0\text{ V to }3.6\text{ V}</math>; <math>T_{amb} = -40\text{ °C to }+85\text{ °C}</math>; <math>C_L = 50\text{ pF}</math></b>						
$t_{PLH}$	LOW-to-HIGH propagation delay	A to Yn; see <a href="#">Figure 5</a> and <a href="#">Figure 8</a>	2.5	3.3	5.9	ns
$t_{PHL}$	HIGH-to-LOW propagation delay	A to Yn; see <a href="#">Figure 5</a> and <a href="#">Figure 8</a>	2.5	3.3	5.9	ns
$t_{PZH}$	OFF-state to HIGH propagation delay	$\overline{OE}$ to Yn; see <a href="#">Figure 6</a> and <a href="#">Figure 8</a>	1.3	-	5.9	ns
$t_{PZL}$	OFF-state to LOW propagation delay	$\overline{OE}$ to Yn; see <a href="#">Figure 6</a> and <a href="#">Figure 8</a>	1.3	-	5.9	ns
$t_{PHZ}$	HIGH to OFF-state propagation delay	$\overline{OE}$ to Yn; see <a href="#">Figure 6</a> and <a href="#">Figure 8</a>	1.7	-	6.3	ns
$t_{PLZ}$	LOW to OFF-state propagation delay	$\overline{OE}$ to Yn; see <a href="#">Figure 6</a> and <a href="#">Figure 8</a>	1.7	-	6.3	ns
$t_{sk(o)}$	output skew time	A to Yn; output-to-output; see <a href="#">Figure 7</a> and <a href="#">Figure 8</a>	-	-	0.5	ns
$t_{sk(p)}$	pulse skew time	A to Yn; see <a href="#">Figure 7</a> and <a href="#">Figure 8</a>	-	-	0.8	ns
$t_{sk(pr)}$	process skew time	A to Yn; part-to-part; see <a href="#">Figure 7</a> and <a href="#">Figure 8</a>	-	-	1	ns
$t_r$	rise time	A to Yn; see <a href="#">Figure 5</a> and <a href="#">Figure 8</a>	0.3	-	2.0	ns
$t_f$	fall time	A to Yn; see <a href="#">Figure 5</a> and <a href="#">Figure 8</a>	0.3	-	2.0	ns

**Table 9: Switching characteristics**

Temperature and  $V_{CC}$  coefficients over recommended operating free-air temperature and  $V_{CC}$  range. [1]

Symbol	Parameter	Conditions	Min	Max	Unit
$\Delta t_{PLH(T)}$	temperature coefficient of LOW-to-HIGH propagation delay A to $Y_n$ (average value)		[2] -	65	ps/10 °C
$\Delta t_{PHL(T)}$	temperature coefficient of HIGH-to-LOW propagation delay A to $Y_n$ (average value)		[2] -	45	ps/10 °C
$\Delta t_{PLH(V)}$	$V_{CC}$ coefficient of LOW-to-HIGH propagation delay A to $Y_n$ (average value)		[3] -	-140	ps/100 mV
$\Delta t_{PHL(V)}$	$V_{CC}$ coefficient of HIGH-to-LOW propagation delay A to $Y_n$ (average value)		[3] -	-120	ps/100 mV

[1] These data were extracted from characterization material and are not tested at the factory.

[2]  $\Delta t_{PLH(T)}$  and  $\Delta t_{PHL(T)}$  are virtually independent of  $V_{CC}$ .

[3]  $\Delta t_{PLH(V)}$  and  $\Delta t_{PHL(V)}$  are virtually independent of temperature.

### 10.1 AC waveforms

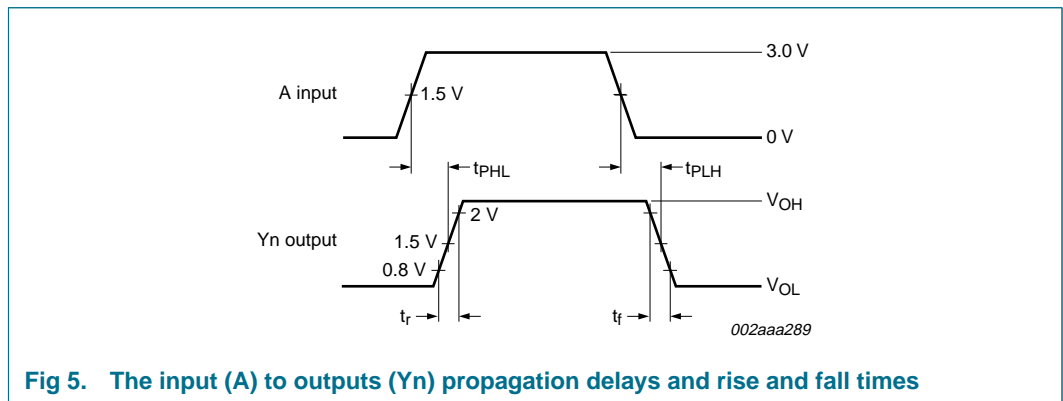

**Fig 5. The input (A) to outputs ( $Y_n$ ) propagation delays and rise and fall times**

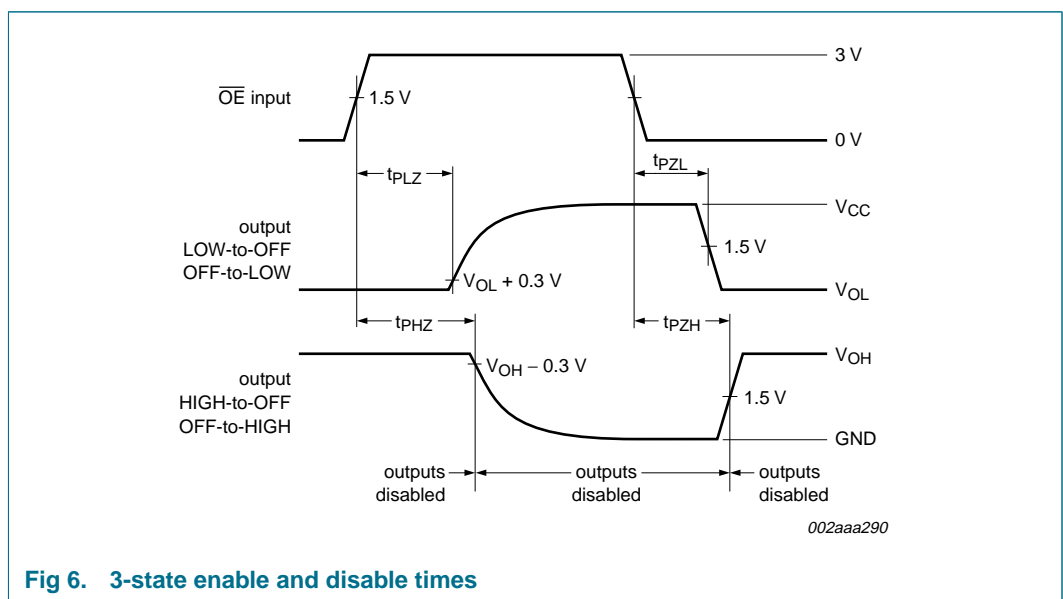

**Fig 6. 3-state enable and disable times**

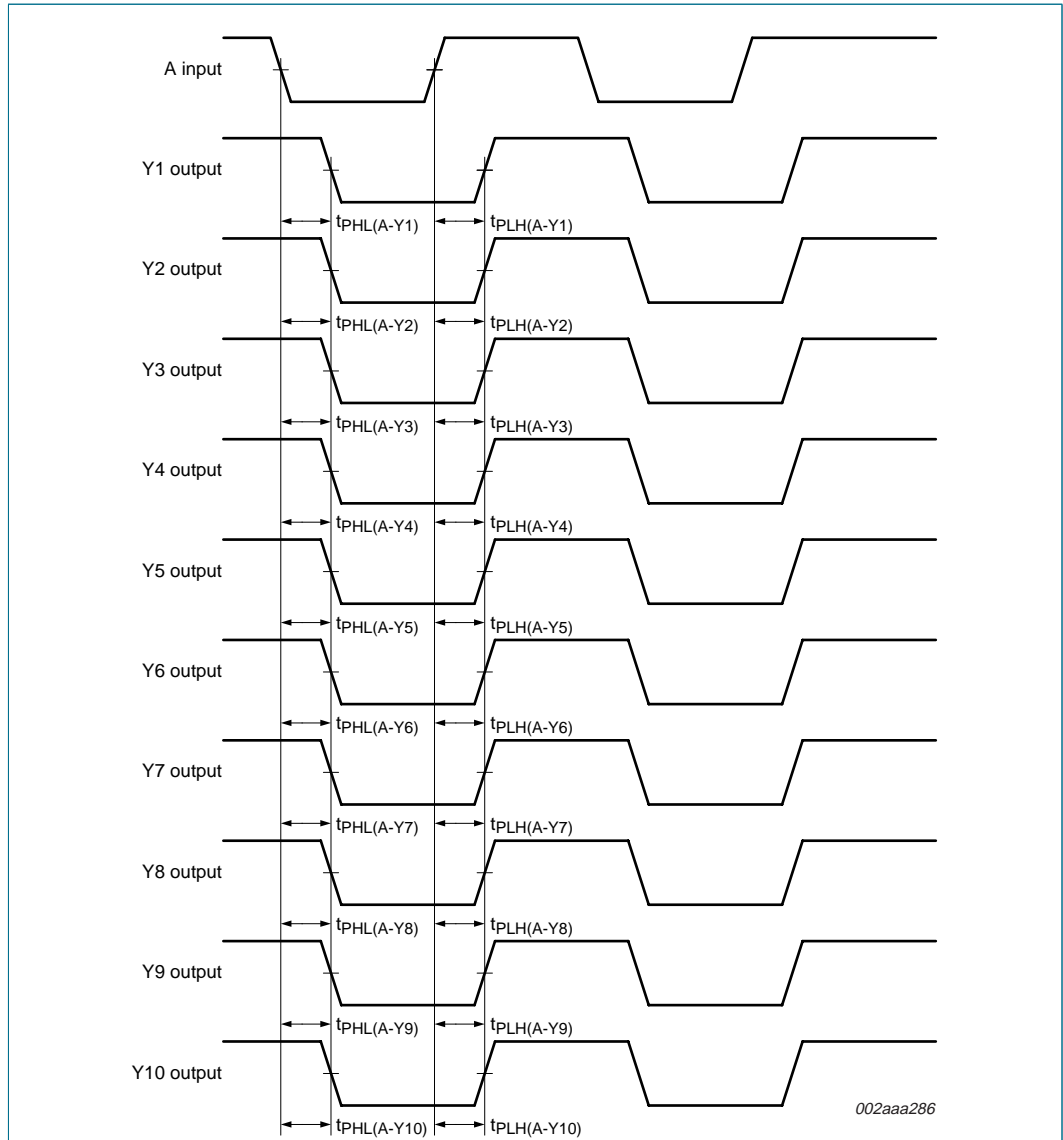

Output-to-output skew is the highest values of positive and negative edge skew:  
 $t_{sk(o)} = t_{PLH(A-Yn)(max)} - t_{PLH(A-Yn)(min)}$  and  $t_{sk(o)} = t_{PHL(A-Yn)(max)} - t_{PHL(A-Yn)(min)}$ .  
 Output pulse skew is the highest value of:  $t_{sk(p)} = |t_{PLH(A-Yn)} - t_{PHL(A-Yn)}|$ .  
 Part-to-part skew  $t_{sk(pr)}$  represents the positive and negative edge skew between outputs of several devices operating under identical conditions.

**Fig 7. Calculation of  $t_{sk(o)}$ ,  $t_{sk(p)}$ , and  $t_{sk(pr)}$**

## 11. Test information

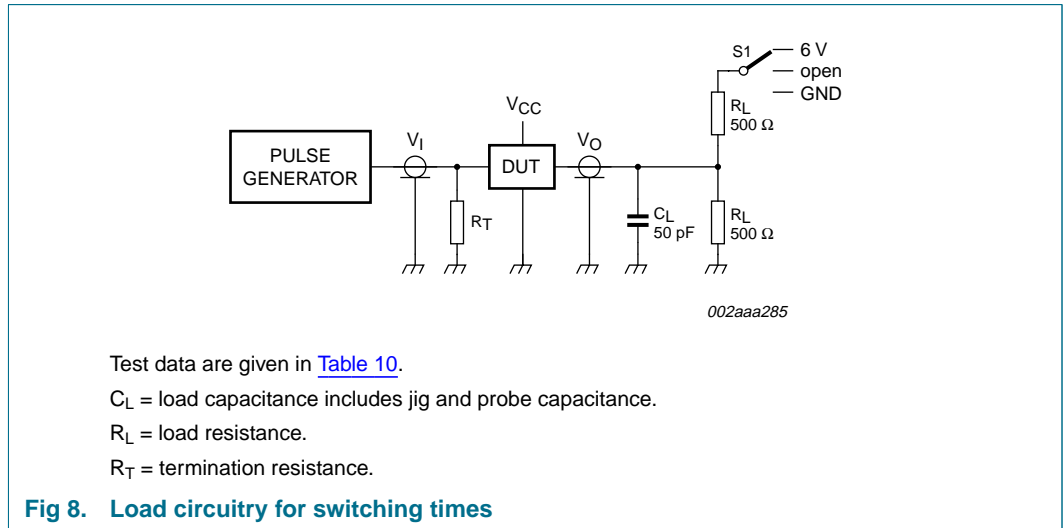

**Table 10: Test data**

Test	Load		Switch
	$C_L$	$R_L$	
$t_{PLH}$ , $t_{PHL}$	50 pF	500 $\Omega$	open
$t_{PLZ}$ , $t_{PZL}$	50 pF	500 $\Omega$	6 V
$t_{PHZ}$ , $t_{PZH}$	50 pF	500 $\Omega$	GND

12. Package outline

SO24: plastic small outline package; 24 leads; body width 7.5 mm

SOT137-1

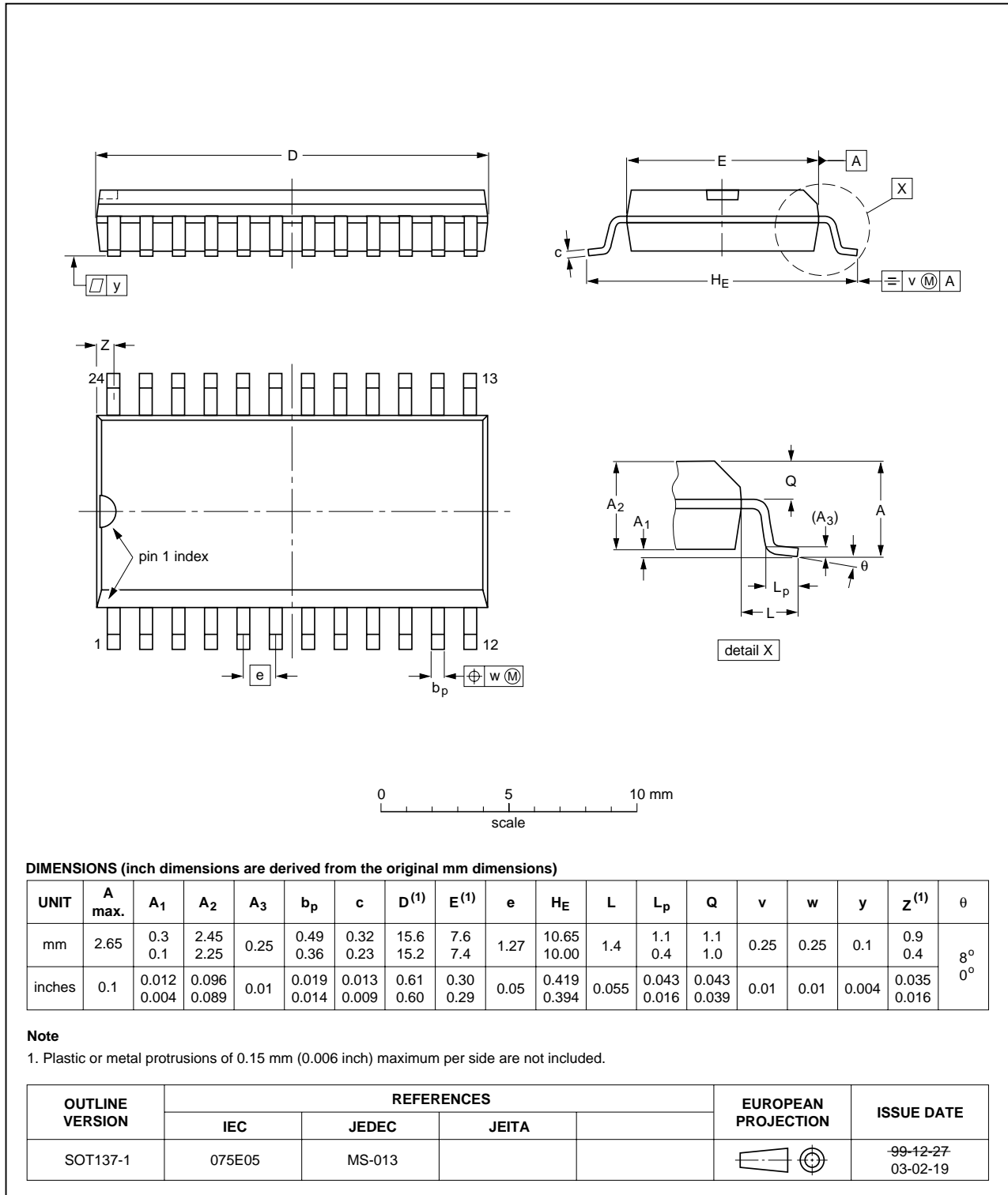

Fig 9. Package outline SOT137-1 (SO24)

SSOP24: plastic shrink small outline package; 24 leads; body width 5.3 mm

SOT340-1

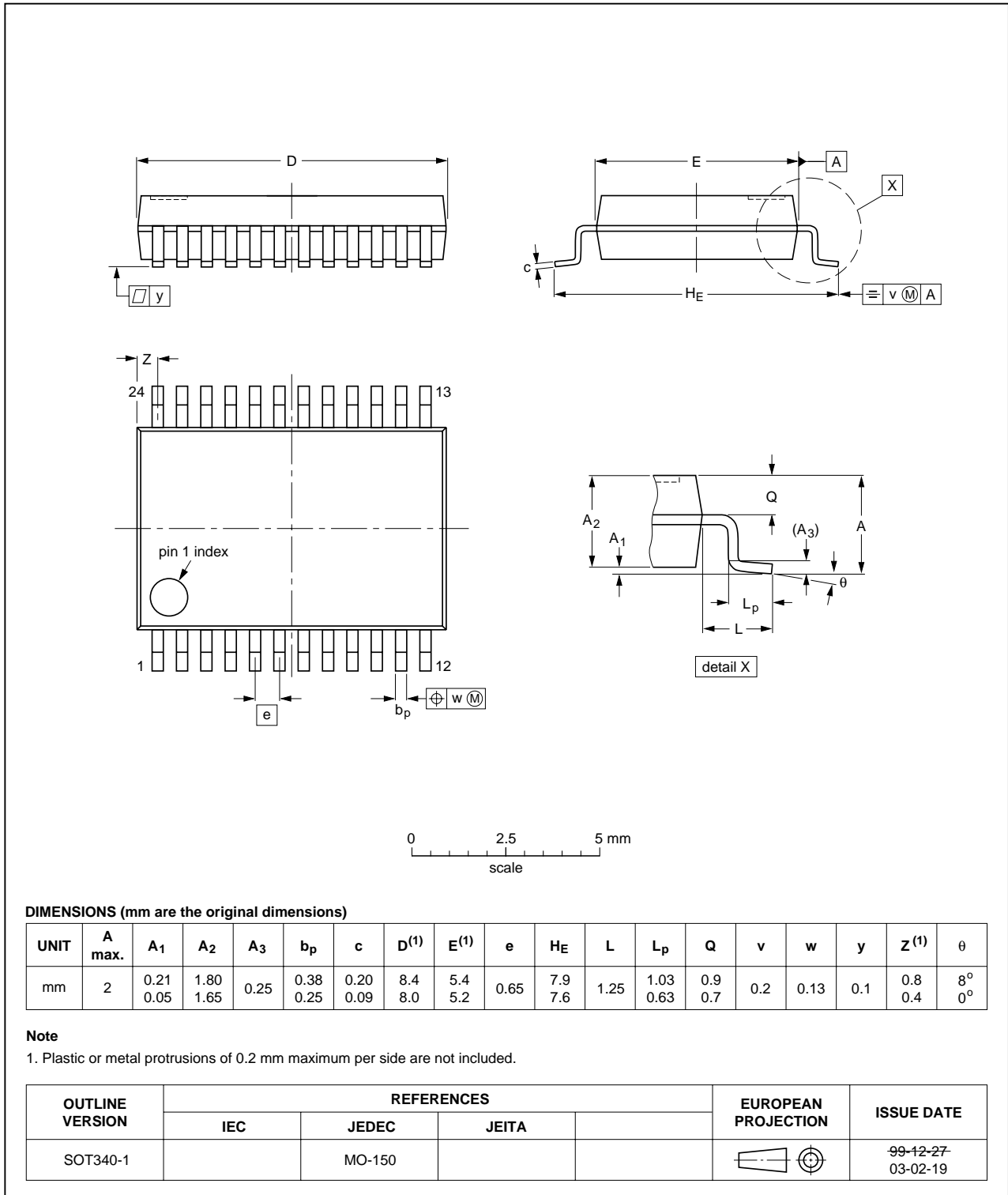

Fig 10. Package outline SOT340-1 (SSOP24)

## 13. Soldering

### 13.1 Introduction to soldering surface mount packages

This text gives a very brief insight to a complex technology. A more in-depth account of soldering ICs can be found in our *Data Handbook IC26; Integrated Circuit Packages* (document order number 9398 652 90011).

There is no soldering method that is ideal for all surface mount IC packages. Wave soldering can still be used for certain surface mount ICs, but it is not suitable for fine pitch SMDs. In these situations reflow soldering is recommended.

### 13.2 Reflow soldering

Reflow soldering requires solder paste (a suspension of fine solder particles, flux and binding agent) to be applied to the printed-circuit board by screen printing, stencilling or pressure-syringe dispensing before package placement. Driven by legislation and environmental forces the worldwide use of lead-free solder pastes is increasing.

Several methods exist for reflowing; for example, convection or convection/infrared heating in a conveyor type oven. Throughput times (preheating, soldering and cooling) vary between 100 seconds and 200 seconds depending on heating method.

Typical reflow peak temperatures range from 215 °C to 270 °C depending on solder paste material. The top-surface temperature of the packages should preferably be kept:

- below 225 °C (SnPb process) or below 245 °C (Pb-free process)
  - for all BGA, HTSSON..T and SSOP..T packages
  - for packages with a thickness  $\geq 2.5$  mm
  - for packages with a thickness  $< 2.5$  mm and a volume  $\geq 350$  mm<sup>3</sup> so called thick/large packages.
- below 240 °C (SnPb process) or below 260 °C (Pb-free process) for packages with a thickness  $< 2.5$  mm and a volume  $< 350$  mm<sup>3</sup> so called small/thin packages.

Moisture sensitivity precautions, as indicated on packing, must be respected at all times.

### 13.3 Wave soldering

Conventional single wave soldering is not recommended for surface mount devices (SMDs) or printed-circuit boards with a high component density, as solder bridging and non-wetting can present major problems.

To overcome these problems the double-wave soldering method was specifically developed.

If wave soldering is used the following conditions must be observed for optimal results:

- Use a double-wave soldering method comprising a turbulent wave with high upward pressure followed by a smooth laminar wave.
- For packages with leads on two sides and a pitch (e):
  - larger than or equal to 1.27 mm, the footprint longitudinal axis is **preferred** to be parallel to the transport direction of the printed-circuit board;

- smaller than 1.27 mm, the footprint longitudinal axis **must** be parallel to the transport direction of the printed-circuit board.

The footprint must incorporate solder thieves at the downstream end.

- For packages with leads on four sides, the footprint must be placed at a 45° angle to the transport direction of the printed-circuit board. The footprint must incorporate solder thieves downstream and at the side corners.

During placement and before soldering, the package must be fixed with a droplet of adhesive. The adhesive can be applied by screen printing, pin transfer or syringe dispensing. The package can be soldered after the adhesive is cured.

Typical dwell time of the leads in the wave ranges from 3 seconds to 4 seconds at 250 °C or 265 °C, depending on solder material applied, SnPb or Pb-free respectively.

A mildly-activated flux will eliminate the need for removal of corrosive residues in most applications.

### 13.4 Manual soldering

Fix the component by first soldering two diagonally-opposite end leads. Use a low voltage (24 V or less) soldering iron applied to the flat part of the lead. Contact time must be limited to 10 seconds at up to 300 °C.

When using a dedicated tool, all other leads can be soldered in one operation within 2 seconds to 5 seconds between 270 °C and 320 °C.

### 13.5 Package related soldering information

**Table 11: Suitability of surface mount IC packages for wave and reflow soldering methods**

Package <sup>[1]</sup>	Soldering method	
	Wave	Reflow <sup>[2]</sup>
BGA, HTSSON..T <sup>[3]</sup> , LBGA, LFBGA, SQFP, SSOP..T <sup>[3]</sup> , TFBGA, VFBGA, XSON	not suitable	suitable
DHVQFN, HBCC, HBGA, HLQFP, HSO, HSOP, HSQFP, HSSON, HTQFP, HTSSOP, HVQFN, HVSON, SMS	not suitable <sup>[4]</sup>	suitable
PLCC <sup>[5]</sup> , SO, SOJ	suitable	suitable
LQFP, QFP, TQFP	not recommended <sup>[5]</sup> <sup>[6]</sup>	suitable
SSOP, TSSOP, VSO, VSSOP	not recommended <sup>[7]</sup>	suitable
CWQCCN..L <sup>[8]</sup> , PMFP <sup>[9]</sup> , WQCCN..L <sup>[8]</sup>	not suitable	not suitable

[1] For more detailed information on the BGA packages refer to the *(LF)BGA Application Note (AN01026)*; order a copy from your Philips Semiconductors sales office.

[2] All surface mount (SMD) packages are moisture sensitive. Depending upon the moisture content, the maximum temperature (with respect to time) and body size of the package, there is a risk that internal or external package cracks may occur due to vaporization of the moisture in them (the so called popcorn effect). For details, refer to the Drypack information in the *Data Handbook IC26; Integrated Circuit Packages; Section: Packing Methods*.

[3] These transparent plastic packages are extremely sensitive to reflow soldering conditions and must on no account be processed through more than one soldering cycle or subjected to infrared reflow soldering with peak temperature exceeding 217 °C ± 10 °C measured in the atmosphere of the reflow oven. The package body peak temperature must be kept as low as possible.

- [4] These packages are not suitable for wave soldering. On versions with the heatsink on the bottom side, the solder cannot penetrate between the printed-circuit board and the heatsink. On versions with the heatsink on the top side, the solder might be deposited on the heatsink surface.
- [5] If wave soldering is considered, then the package must be placed at a 45° angle to the solder wave direction. The package footprint must incorporate solder thieves downstream and at the side corners.
- [6] Wave soldering is suitable for LQFP, QFP and TQFP packages with a pitch (e) larger than 0.8 mm; it is definitely not suitable for packages with a pitch (e) equal to or smaller than 0.65 mm.
- [7] Wave soldering is suitable for SSOP, TSSOP, VSO and VSSOP packages with a pitch (e) equal to or larger than 0.65 mm; it is definitely not suitable for packages with a pitch (e) equal to or smaller than 0.5 mm.
- [8] Image sensor packages in principle should not be soldered. They are mounted in sockets or delivered pre-mounted on flex foil. However, the image sensor package can be mounted by the client on a flex foil by using a hot bar soldering process. The appropriate soldering profile can be provided on request.
- [9] Hot bar soldering or manual soldering is suitable for PMFP packages.

## 14. Revision history

Table 12: Revision history

Document ID	Release date	Data sheet status	Change notice	Doc. number	Supersedes
PCK351_2	20051216	Product data sheet	-	-	PCK351-01
Modifications:	<ul style="list-style-type: none"> <li>• The format of this data sheet has been redesigned to comply with the new presentation and information standard of Philips Semiconductors.</li> <li>• <a href="#">Section 2 “Features”</a>: deleted (old) 12th bullet</li> <li>• <a href="#">Table 2 “Ordering information”</a>: changed “Temperature range = –65 °C to +150 °C” to “T<sub>amb</sub> = –40 °C to +85 °C”</li> <li>• <a href="#">Table 5 “Limiting values”</a>: <ul style="list-style-type: none"> <li>– removed (old) Table note [1]; this is now presented in the Definitions section</li> <li>– symbol “I<sub>O</sub>” changed to “I<sub>O(sink)</sub>”</li> <li>– row “I<sub>CC</sub>, I<sub>GND</sub>” split to 2 rows, and parameter for each revised</li> </ul> </li> <li>• <a href="#">Table 6 “Recommended operating conditions”</a>: <ul style="list-style-type: none"> <li>– moved (old) Table note [1] to description below table title</li> <li>– split row “t<sub>r</sub>, t<sub>f</sub>”</li> </ul> </li> <li>• <a href="#">Table 7 “Static characteristics”</a>: changed parameter description of V<sub>IK</sub> from “input diode voltage” to “input clamping voltage”</li> <li>• <a href="#">Table 8 “Dynamic characteristics”</a>: <ul style="list-style-type: none"> <li>– in descriptive line below table title: changed “t<sub>r</sub> = t<sub>f</sub> ≤ 3.0 ns” to “t<sub>r</sub> = t<sub>f</sub> ≤ 2.5 ns”</li> <li>– (V<sub>CC</sub> = 3.3 V) typical value for t<sub>PLH</sub> and t<sub>PHL</sub> (A to Yn) changed from 3.6 ns to 3.8 ns</li> <li>– (V<sub>CC</sub> = 3.3 V) typical value for t<sub>PHZ</sub> and t<sub>PZH</sub> (<math>\overline{OE}</math> to Yn) changed from 4.0 ns to 3.8 ns</li> <li>– (V<sub>CC</sub> = 3.3 V) t<sub>r</sub> and t<sub>f</sub> minimum values changed from “-” to “0.3 ns”; maximum values changed from “-” to “2.0 ns”</li> <li>– subheading “V<sub>CC</sub> = 3.3 to 3.6 V; T<sub>amb</sub> = 0 °C to +70 °C” changed to “V<sub>CC</sub> = 3.0 V to 3.6 V; T<sub>amb</sub> = –40 °C to +85 °C”</li> <li>– (V<sub>CC</sub> = 3.0 V to 3.6 V) values for t<sub>PLH</sub> and t<sub>PHL</sub> (A to Yn) changed from “-” to “2.5 ns” (min), “3.3 ns” (typ), “5.9 ns” (max)</li> <li>– (V<sub>CC</sub> = 3.0 V to 3.6 V) t<sub>r</sub> and t<sub>f</sub> minimum values changed from “-” to “0.3 ns”; maximum values changed from “-” to “2.0 ns”</li> </ul> </li> </ul>				
PCK351-01	20020514	Product data	853-2344 28198	9397 750 09791	-

## 15. Data sheet status

Level	Data sheet status <sup>[1]</sup>	Product status <sup>[2] [3]</sup>	Definition
I	Objective data	Development	This data sheet contains data from the objective specification for product development. Philips Semiconductors reserves the right to change the specification in any manner without notice.
II	Preliminary data	Qualification	This data sheet contains data from the preliminary specification. Supplementary data will be published at a later date. Philips Semiconductors reserves the right to change the specification without notice, in order to improve the design and supply the best possible product.
III	Product data	Production	This data sheet contains data from the product specification. Philips Semiconductors reserves the right to make changes at any time in order to improve the design, manufacturing and supply. Relevant changes will be communicated via a Customer Product/Process Change Notification (CPCN).

[1] Please consult the most recently issued data sheet before initiating or completing a design.

[2] The product status of the device(s) described in this data sheet may have changed since this data sheet was published. The latest information is available on the Internet at URL <http://www.semiconductors.philips.com>.

[3] For data sheets describing multiple type numbers, the highest-level product status determines the data sheet status.

## 16. Definitions

**Short-form specification** — The data in a short-form specification is extracted from a full data sheet with the same type number and title. For detailed information see the relevant data sheet or data handbook.

**Limiting values definition** — Limiting values given are in accordance with the Absolute Maximum Rating System (IEC 60134). Stress above one or more of the limiting values may cause permanent damage to the device. These are stress ratings only and operation of the device at these or at any other conditions above those given in the Characteristics sections of the specification is not implied. Exposure to limiting values for extended periods may affect device reliability.

**Application information** — Applications that are described herein for any of these products are for illustrative purposes only. Philips Semiconductors makes no representation or warranty that such applications will be suitable for the specified use without further testing or modification.

## 17. Disclaimers

**Life support** — These products are not designed for use in life support appliances, devices, or systems where malfunction of these products can reasonably be expected to result in personal injury. Philips Semiconductors

## 19. Contact information

For additional information, please visit: <http://www.semiconductors.philips.com>

For sales office addresses, send an email to: [sales.addresses@www.semiconductors.philips.com](mailto:sales.addresses@www.semiconductors.philips.com)

customers using or selling these products for use in such applications do so at their own risk and agree to fully indemnify Philips Semiconductors for any damages resulting from such application.

**Right to make changes** — Philips Semiconductors reserves the right to make changes in the products - including circuits, standard cells, and/or software - described or contained herein in order to improve design and/or performance. When the product is in full production (status 'Production'), relevant changes will be communicated via a Customer Product/Process Change Notification (CPCN). Philips Semiconductors assumes no responsibility or liability for the use of any of these products, conveys no license or title under any patent, copyright, or mask work right to these products, and makes no representations or warranties that these products are free from patent, copyright, or mask work right infringement, unless otherwise specified.

## 18. Trademarks

**Notice** — All referenced brands, product names, service names and trademarks are the property of their respective owners.

## 20. Contents

<b>1</b>	<b>General description</b> .....	<b>1</b>
<b>2</b>	<b>Features</b> .....	<b>1</b>
<b>3</b>	<b>Quick reference data</b> .....	<b>2</b>
<b>4</b>	<b>Ordering information</b> .....	<b>2</b>
<b>5</b>	<b>Functional diagram</b> .....	<b>3</b>
<b>6</b>	<b>Pinning information</b> .....	<b>4</b>
6.1	Pinning .....	4
6.2	Pin description .....	4
<b>7</b>	<b>Functional description</b> .....	<b>5</b>
7.1	Function table .....	5
7.2	Logic symbol .....	5
<b>8</b>	<b>Limiting values</b> .....	<b>6</b>
<b>9</b>	<b>Recommended operating conditions</b> .....	<b>6</b>
<b>10</b>	<b>Characteristics</b> .....	<b>7</b>
10.1	AC waveforms .....	9
<b>11</b>	<b>Test information</b> .....	<b>11</b>
<b>12</b>	<b>Package outline</b> .....	<b>12</b>
<b>13</b>	<b>Soldering</b> .....	<b>14</b>
13.1	Introduction to soldering surface mount packages .....	14
13.2	Reflow soldering .....	14
13.3	Wave soldering .....	14
13.4	Manual soldering .....	15
13.5	Package related soldering information .....	15
<b>14</b>	<b>Revision history</b> .....	<b>16</b>
<b>15</b>	<b>Data sheet status</b> .....	<b>17</b>
<b>16</b>	<b>Definitions</b> .....	<b>17</b>
<b>17</b>	<b>Disclaimers</b> .....	<b>17</b>
<b>18</b>	<b>Trademarks</b> .....	<b>17</b>
<b>19</b>	<b>Contact information</b> .....	<b>17</b>



© Koninklijke Philips Electronics N.V. 2005

All rights are reserved. Reproduction in whole or in part is prohibited without the prior written consent of the copyright owner. The information presented in this document does not form part of any quotation or contract, is believed to be accurate and reliable and may be changed without notice. No liability will be accepted by the publisher for any consequence of its use. Publication thereof does not convey nor imply any license under patent- or other industrial or intellectual property rights.

Date of release: 16 December 2005  
Document number: PCK351\_2

Published in The Netherlands